

RKH

WWW.RAKONHELI.COM

Step 01

- Take the canopy off.
- Remove Landing Gear and Main Gear.

Step 02: Remove 3 screws as shown below:

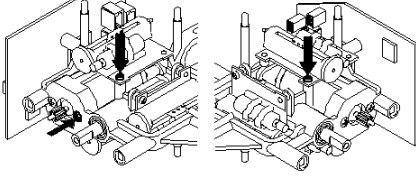

Step 03: Assembly Tail Boom Support Mount

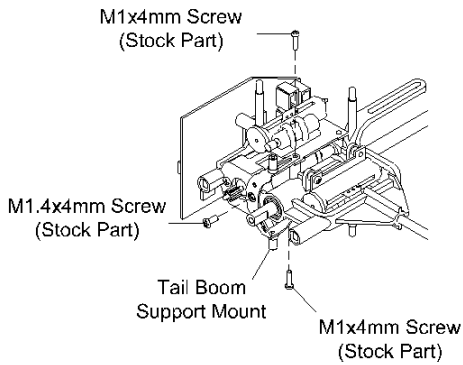

Step 04: Assembly Tail Boom Support.

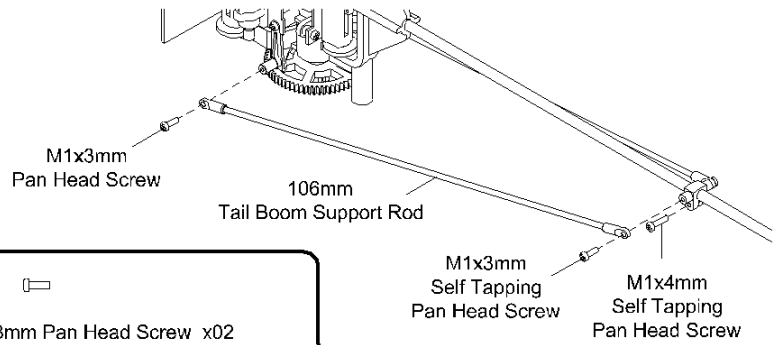

M1x3mm Pan Head Screw x02

M1x3mm Self Tapping Pan Head Screw x02 M1x4mm Self Tapping Pan Head Screw x01

Step 05: Re-assembly Main Gear, Landing Gear and Canopy (Finish).

mCPX Tail Boom Support
mCPX812

DESIGN A

RKH

WWW.RAKONHELI.COM

Step 01

- Take the canopy off.
- Remove Landing Gear and Main Gear.

Step 02: Mark and drill 1mm hole through the plastic frame.

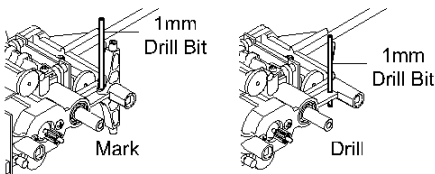

Step 03: Assembly Tail Boom Support Mount

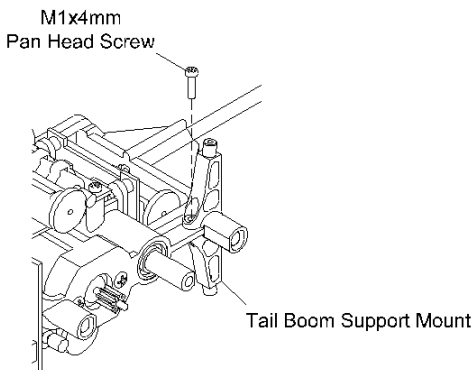

Step 04: Assembly Tail Boom Support.

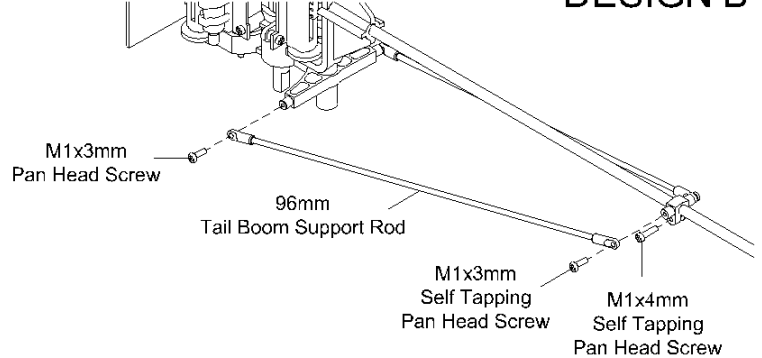

M1x3mm Pan Head Screw x02

M1x4mm Pan Head Screw x01

M1x3mm Self Tapping Pan Head Screw x02 M1x4mm Self Tapping Pan Head Screw x01

Step 05: Re-assembly Main Gear, Landing Gear and Canopy (Finish).

mCPX Tail Boom Support
mCPX812

DESIGN B