

Rotor Head Assembly 1

旋翼頭組立1

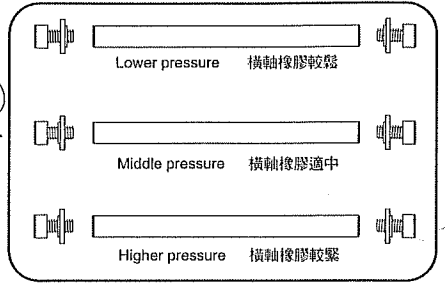

1. Join the yoke and center hub, install the head spacer & damper as shown in figure. 將T型頭鎖至鋁軸上並將橡膠環套在圓盤後利用小起子硬塞入T型頭兩側。
2. Install the parts in that order. (Notice: S - smaller hole, L - Larger hole) 利用橫軸為治具，先套入軸承及止推 (注意: S-小孔, L-大孔) 再壓入夾頭內。

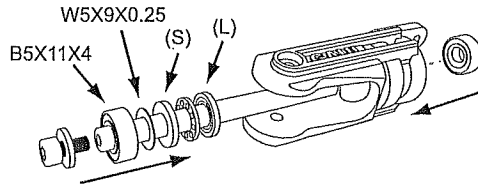
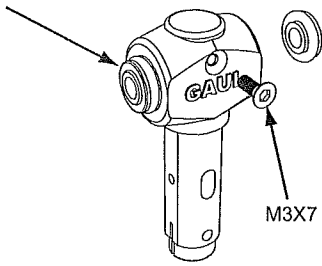
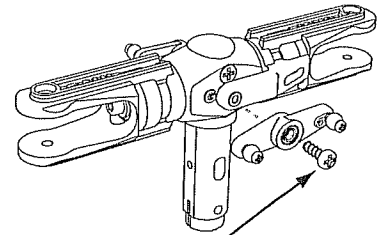
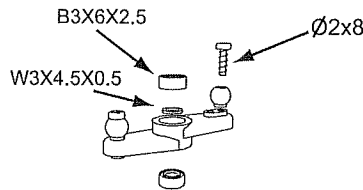
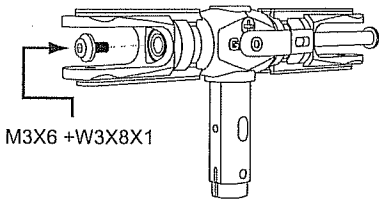

3. Assemble grips and yoke, tighten the two screws of spindle shaft. 完成兩個主旋翼夾頭後再以橫軸對鎖。
4. Assemble both of the mixing levers and join them to the grips. 組合搖臂並鎖至夾頭上。

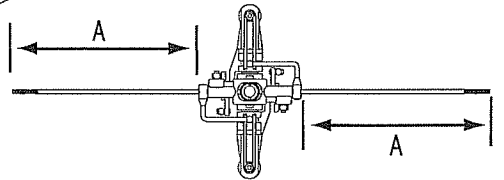
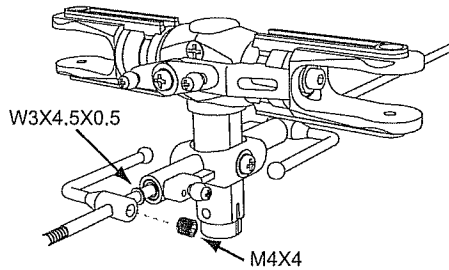
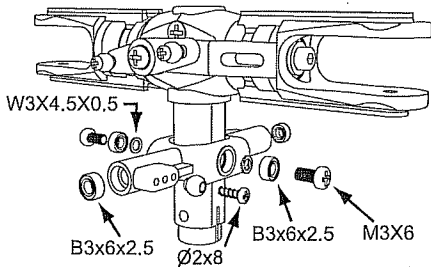

5. Install the seesaw onto the center hub. 將平衡桿座鎖至鋁軸上。
6. Install the flybar arms onto the flybar. 將L臂固定在平衡桿上。
7. Make sure the both length of the flybar should be exact the same. 注意: 平衡桿兩端距離需一致。

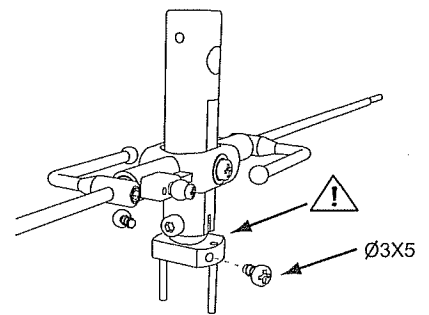
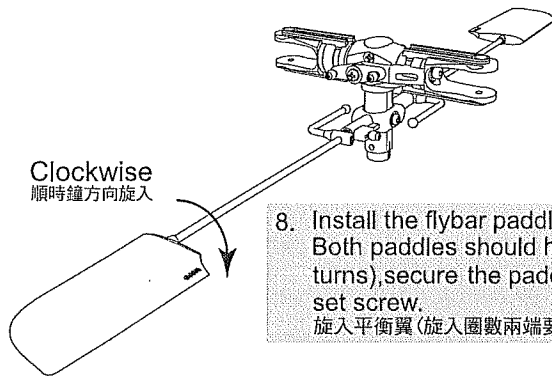

8. Install the flybar paddle by turning (Both paddles should have the same turns), secure the paddle by M3x3 set screw. 旋入平衡翼 (旋入圈數兩端要相同)。
9. Install washout guide. (The slot should be in the exact position and do not overtight the screw. 鎖上定位器 (注意凹槽位置並且不要過份鎖緊))

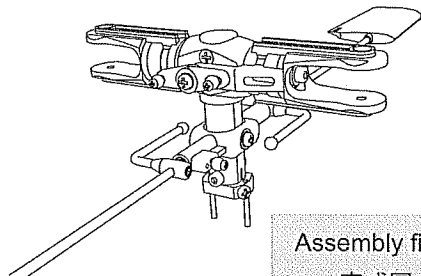

Assembly figure
完成圖