



Instruction Manual F-15 Eagle

DISCLAIMER

6mmFlyRC guarantees our kits to be free from defects in both material and workmanship at the date of purchase. This warranty does not cover any component parts damaged by use or modification. In no case shall 6mmFlyRC's liability exceed the original cost of the purchased kit. Further, 6mmFlyRC reserves the right to change or modify this warranty without notice.

In that 6mmFlyRC has no control over the final assembly or material used for final assembly, no liability shall be assumed nor accepted for any damage resulting from the use by the user of the final user-assembled product. By the act of using the user-assembled product, the user accepts all resulting liability.

If the buyer is not prepared to accept the liability associated with the use of this product, the buyer is advised to return this kit immediately in new and unused condition to 6mmFlyRC for a full refund.

While this kit has been flight tested for normal use, if the plane will be used for extremely high stress flying, such as racing, the modeler is responsible for taking steps to reinforce the high stress points.

***Special thanks to Steve Shumate**, who not only has provided the instructions for the T-38, F-14, F-15, F-18, and Saab Gripen, but has provided much needed support to 6mmFlyRC. Without Steve, our job would be much harder.



This model was designed to be built from either BlueCore fan-fold foam or 6 mm Depron foam. If using BlueCore, note you'll need to peel the film backing off the fuselage exterior parts to allow sanding the fuselage corners to shape. Leave the film on the wing and empennage parts since it adds strength, durability, and smoothness.

This model can be built using the following types of adhesives:

- Epoxy
- Odorless cyanoacrylate (CA) with accelerator
- UHU Creativ for Styrofoam (or UHU POR)
- 3M 77 spray adhesive
- Hot glue gun
- ProBond (or Gorilla Glue)

To minimize weight, try to use as little epoxy as possible on this model, saving it for only critical joints such as wing spars and motor mounts. The majority of construction should use a lightweight and quick-drying adhesive such as CA, UHU Creativ, or 3M 77. I personally use 3M 77 and UHU Creativ (picture at left) for the majority of construction.

Begin by cutting out all of the paper parts templates with scissors, trimming them to within approximately 1/8" of the lines. Then test fit all of the templates onto the foam sheet, trying to minimize wasted foam as much as possible. Once you're satisfied with the arrangement, remove each template individually and spray the back of the template LIGHTLY with 3M 77 spray adhesive. Then replace the template onto the same spot on the foam sheet. Repeat for every template.

After all the templates are tacked onto the foam, cut out all the pieces by cutting on the lines with a SHARP hobby knife. When done, peel the paper templates off of each piece and discard.

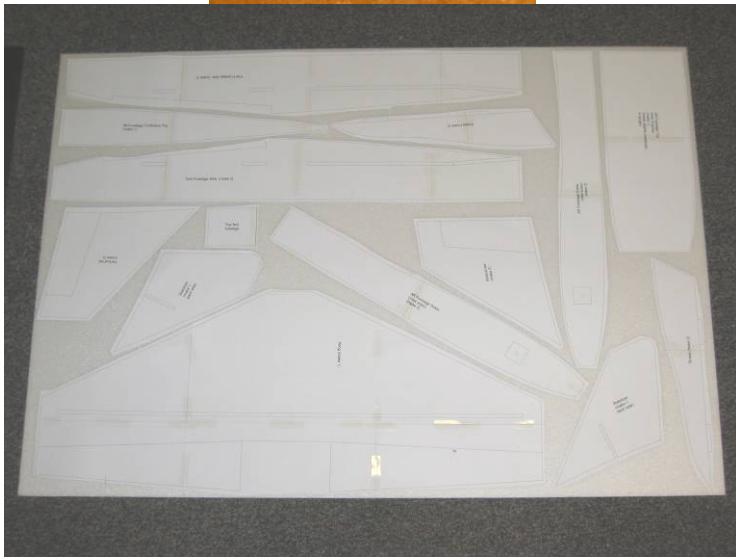



1. Start assembly with the forward fuselage. Lay the two fuselage sides down flat on the work bench and glue the foam corner doublers to the locations shown on the plans. Make sure to make two mirror image parts—a left side and a right side. Either 3M 77 spray adhesive or UHU Creativ works best for this step. *[Note: These photos show the prototype model, which used balsa triangle stock at the corners. The updated design now uses foam strip doublers at the corners, which are just as strong and can be sanded to a more rounded shape.]*

After the glue has dried, glue the three fuselage bulkheads to one of the fuselage sides at the locations shown, making sure they are perpendicular.

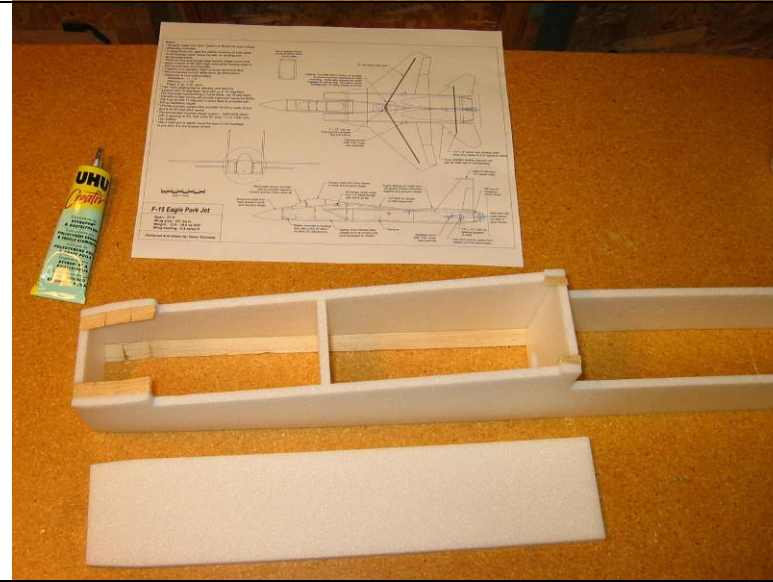

2. Next glue the two fuselage sides together. Set the sides upright and flat on the workbench, apply glue to the edge of the bulkheads (contact glue or odorless CA recommended), and push the sides together. Note the aft end is left open at this point—it will be glued together later after the aft fuselage assembly is attached.

After the glue has dried, glue on the forward fuselage bottom piece and the forward fuselage top piece.

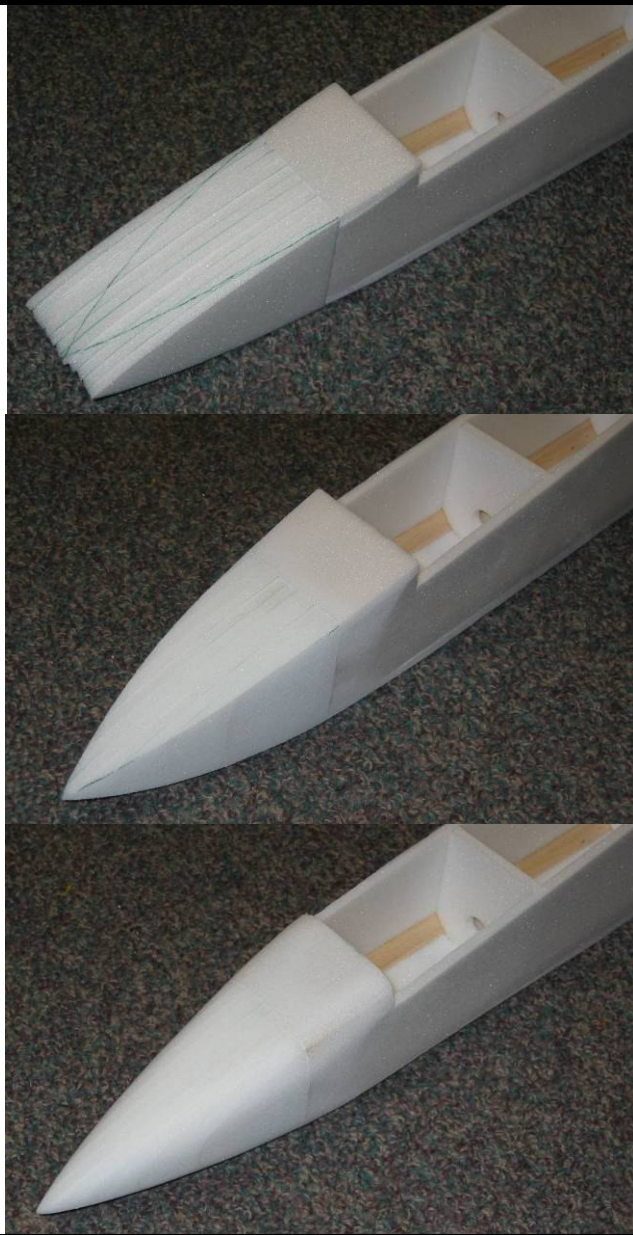

3. Laminate all of the nosecone pieces together using 3M 77 adhesive. Then glue the nosecone block to the front of the fuselage.

Once the glue has dried, sand the nosecone and forward fuselage to shape. Start by tracing the top outline of the nosecone onto the foam and cut to shape with a long knife or saw. Begin with coarse sandpaper (100 grit) to rough out the basic shape, then move to a finer sandpaper (220 grit) to do the final shaping. End with 320 grit sandpaper to do the final polish sanding and provide a very smooth surface.



4. Carve the canopy to shape using the same procedure as the nosecone.



5. Now begin assembly of the aft fuselage. Notice on the plans how the fuselage top and bottom have a gentle curve at the aft end of the fuselage that forms the exhaust nozzles. Assembly of these parts goes much easier if you first pre-form these curves into the foam pieces using a heat gun. This is very easy to do! Just hold the heat gun about a foot or two away from the foam and heat the foam SLIGHTLY (it doesn't take much). Then gently bend the foam with your hands to the curves required (note the foam will spring back some, so the initial bends need to be slightly more than what's required). If you bend the foam too much don't worry about it—it's easy to reheat the foam and take the bend back out. To judge how much curvature is required for each piece, simply hold it up next to the part it attaches to and keep bending it until it matches fairly closely.



6. Glue the foam corner doublers, foam support strip, and plywood stab mounts to the two fuselage sides at the locations shown on the plans. Make sure to make left and right mirror image pieces.

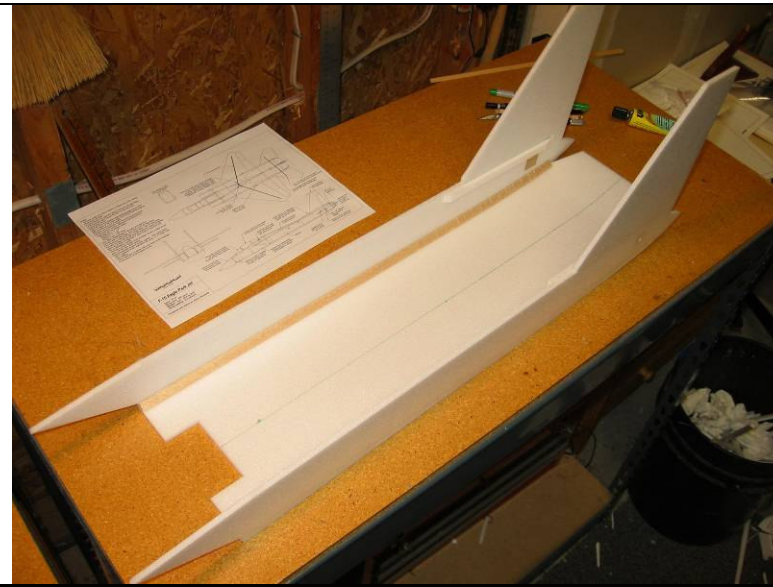

7. Draw a centerline on the inside of the fuselage bottom piece. This line will help with aligning other parts later.

Glue the two fuselage sides to the bottom piece (the centerline should be on the inside as shown).

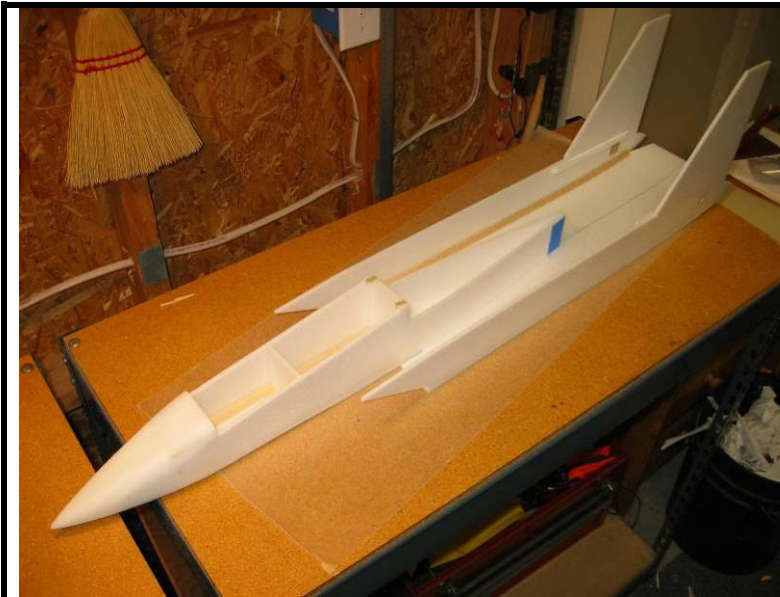

8. Now glue the forward and aft fuselage assemblies together. Draw a small centerline mark on the inside of the forward fuselage bottom piece, and align that mark with the centerline of the aft fuselage piece. Apply glue (5 minute epoxy recommended) to the bottom edges of the forward fuselage sides, and to the free aft ends of the forward fuselage sides. Then temporarily tape the two free aft ends of the forward fuselage together. Make sure everything is properly aligned, then press the forward fuselage down onto the aft fuselage on a flat surface. Adjust the taped ends of the forward fuselage as required to make sure they are aligned on the centerline of the aft fuselage. Let this cure thoroughly.



9. Laminate the two identical motor mount supports together (3M 77 spray adhesive recommended). After the glue is dry, glue in the hardwood motor mount with 5 minute epoxy and let it cure. Check the fit of the elevator servo used, and trim or shim the foam as required for a tight fit. Glue the plywood stabilator support pieces to each side of the motor mount supports, centered over the stabilator pivot holes.

Glue the motor mount support into the aft fuselage (5 min epoxy recommended), making sure it is aligned with the centerline drawn on the fuselage bottom.

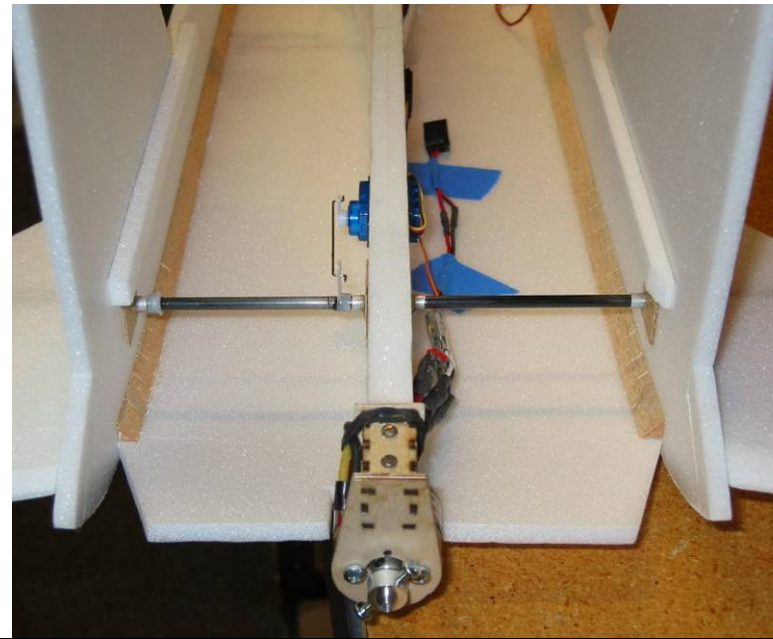
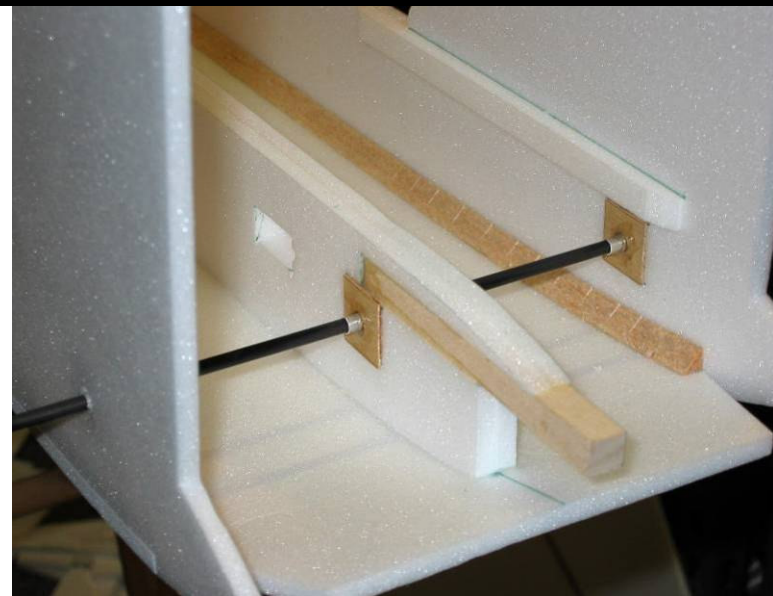

10. Next install the hardware for the pivoting stabilators. The .157" diameter carbon stabilator rod pivots inside three short pieces of 3/16" diameter aluminum, which are supported by four small squares of 1/64" ply glued to the fuselage sides (study the plans carefully here!).

Drill 3/16" holes through all of the plywood stab pivot supports. Use the precut holes in the foam to guide the drill for the outer pieces, then push the drill bit through and hold the drill as square as possible while drilling the center plywood pieces. Then test fit the three aluminum tube bearings into the holes and try to slide the carbon stabilator rod in to check fit. If your drilling was a little off (and it probably was), you may need to enlarge the hole in the center motor mount slightly to reposition the bearing and allow the carbon rod to turn freely (don't worry about creating gaps here, since we'll use epoxy to glue this tube in which will fill the gaps).

Once everything fits and the carbon rod turns freely, apply 5 minute epoxy around each of the three aluminum tubes to glue them in place. Note the carbon rod should still be inside the bearings to hold them in alignment—but make sure not to get epoxy on the carbon rod.

Once the epoxy is cured, remove the carbon rod. Two parts then need to be slid onto the carbon rod—the control horn and the end stop bearing. Both of these parts are on the left side of the fuselage between the fuselage side and motor mount (the control horn goes in the center and the end stop goes on the outboard end), and are what keeps the carbon rod from sliding left and right so the stabilator edges don't rub against the fuselage sides. Slide the carbon rod back in to the fuselage, sliding these two parts on at the same time (but don't glue them in yet).

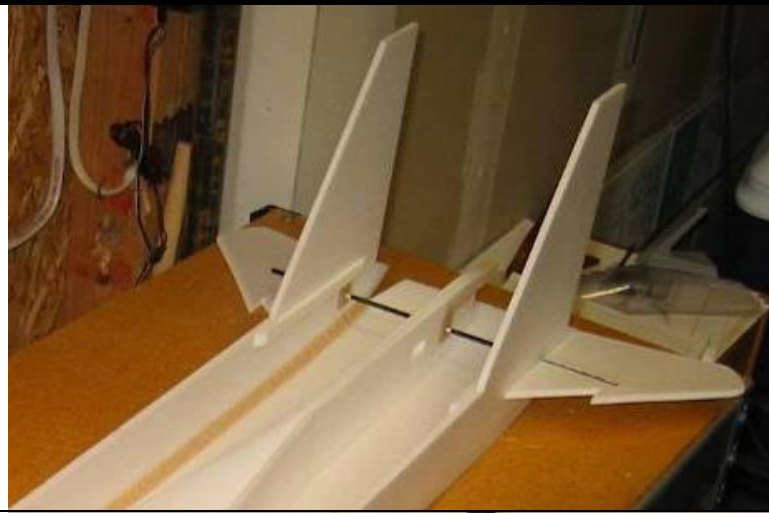

11. Shape the stabilator leading and trailing edges with fine sandpaper (220 grit), sanding a round contour on the leading edge and a tapered contour on the trailing edge. Then glue the left stabilator onto the carbon rod with 5 minute epoxy, making sure the carbon tube is centered in the fuselage.

After the glue cures, glue on the right stabilator, making sure it is aligned with the left stabilator and that both stabilators are flush with the fuselage sides. Once the glue is cured, check the stabilator pivoting and make sure it turns freely. Touch up sand the fuselage sides and/or stabilator ends as required so that they don't rub.

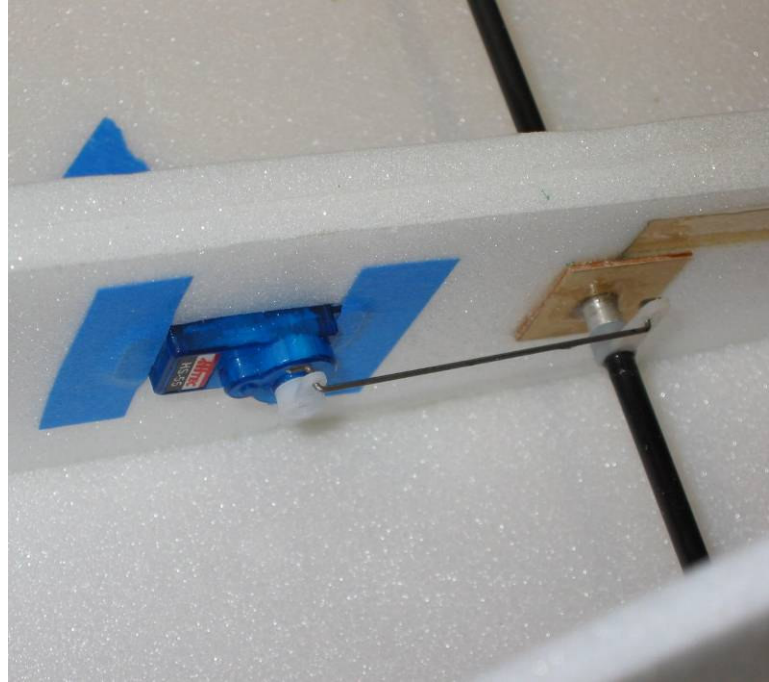

12. Now install the elevator servo. The servo should fit very tightly, and short pieces of tape are used to hold it in place.

Make a pushrod from 1/32" music wire and install it (Z-bends are recommended at both ends).

After the pushrod is installed, get everything aligned:

- Center the servo arm vertically
- Center the stabilator control horn vertically
- Make sure the stabilators are flush with the fuselage sides and at neutral (0 degrees deflection)
- Make sure the end stop and control horn are flush against the aluminum tube bearings (so that there's no side-to-side motion)

After all of these are aligned, glue the control horn and end stop to the carbon rod with CA glue and accelerator.

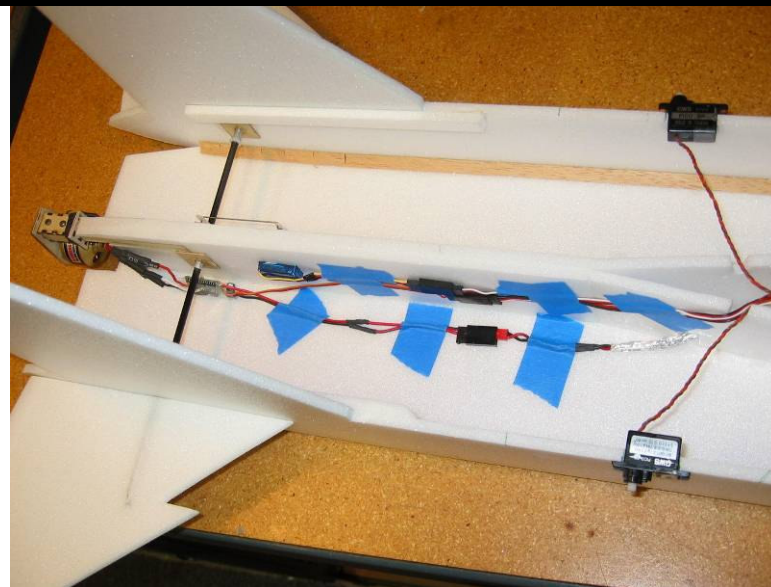

13. Next install the receiver and speed control. The receiver fits in the aft part of the center fuselage, and the ESC is installed wherever is most convenient inside the inlet ducts. A small hole must be cut in the foam wall of the receiver compartment to pass the speed control and elevator servo leads. Tape all wires leading to and from the speed control and servo to the fuselage sides inside the inlets. Plug the elevator servo leads into the receiver.

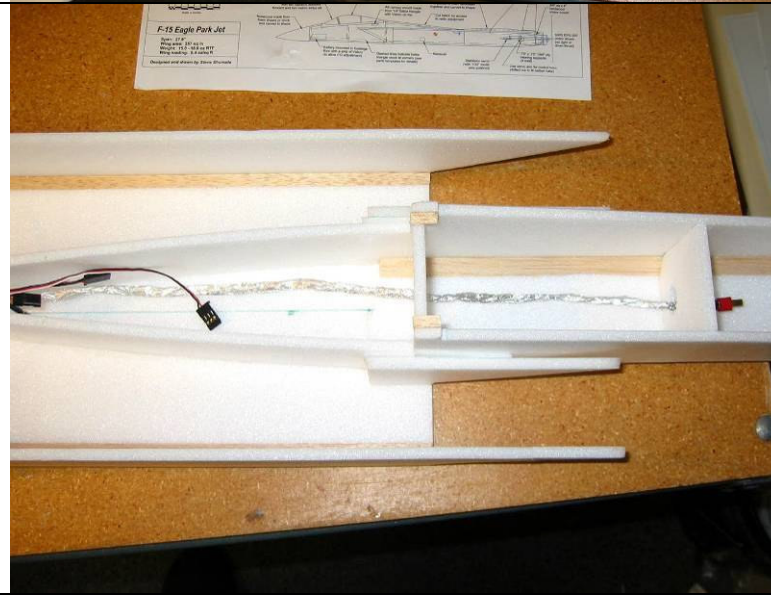

14. Make a wire extension to connect the battery in the forward fuselage to the ESC in the aft fuselage. Use at least 16 gauge wire. To reduce the amount of RF interference with the receiver, twist the wires in the extension together and also wrap them tightly with 3 or 4 layers of household aluminum foil. This will provide shielding that should reduce glitches. Solder the connectors of choice to both ends (Deans Ultra connectors are recommended).

For most installations, the battery will probably end up at the very forward end of the battery compartment, so make sure to make the wire extension is long enough to reach that area.

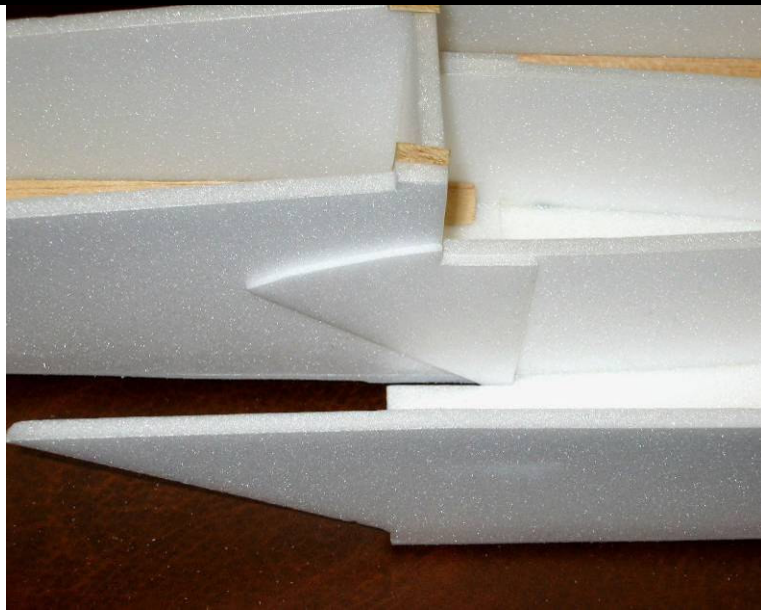

15. To provide a scale-appearing inlet boundary layer diverter, there are two pieces that are installed in the inboard side of the inlet openings. The inner piece is made of 3mm Depron and provides the scale gap between the inlet and fuselage. The other piece is 6mm Depron and forms the inboard side of the inlet itself.

Glue the inner pieces to the fuselage sides first as shown in the top picture at left, then glue the second piece on top of the first as shown in the bottom picture.

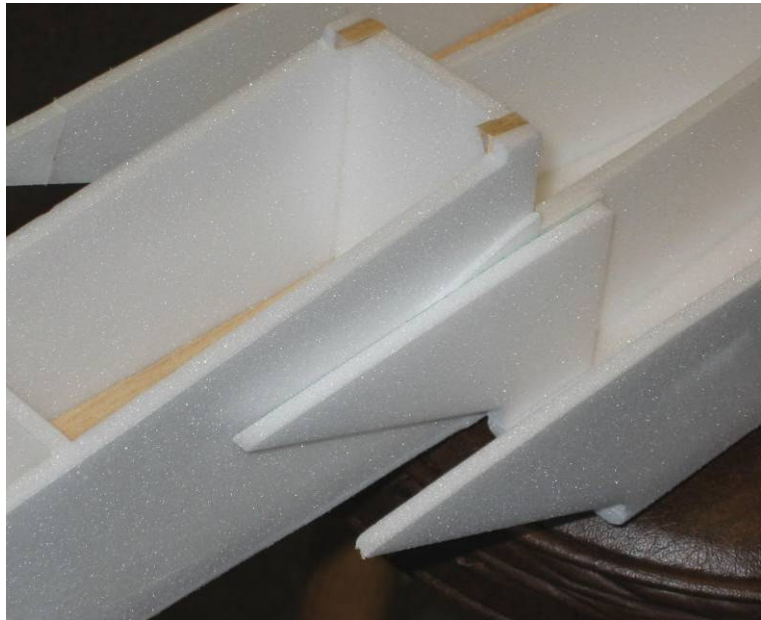

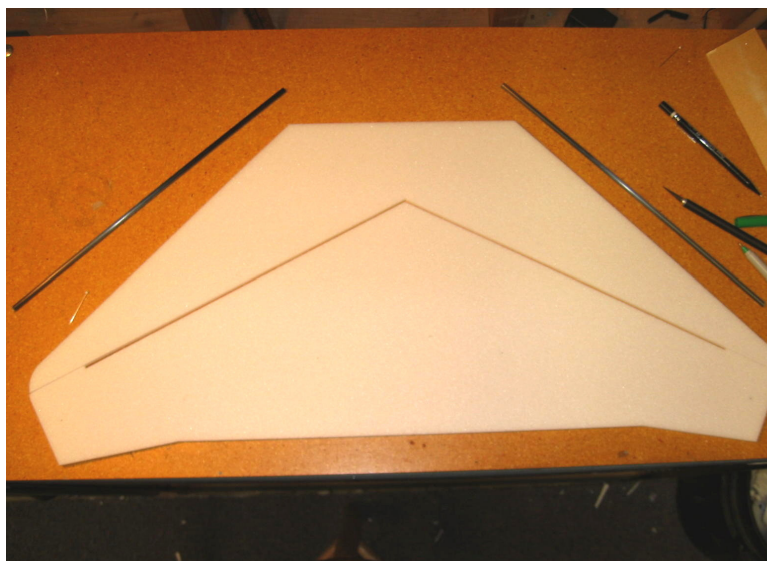

16. Begin wing construction. Start by sanding the wing leading edge to a well-rounded shape and the wing trailing edge to a tapered shape. Cover the wing leading edge with a strip of 3M Satin tape to provide smoothness and improve durability.

Cut a notch in the foam to fit the carbon tube wing spar. *[Note: These photos show the prototype model which used a swept two-piece wing spar design. The updated design uses a simpler and stronger single piece straight spar.]*

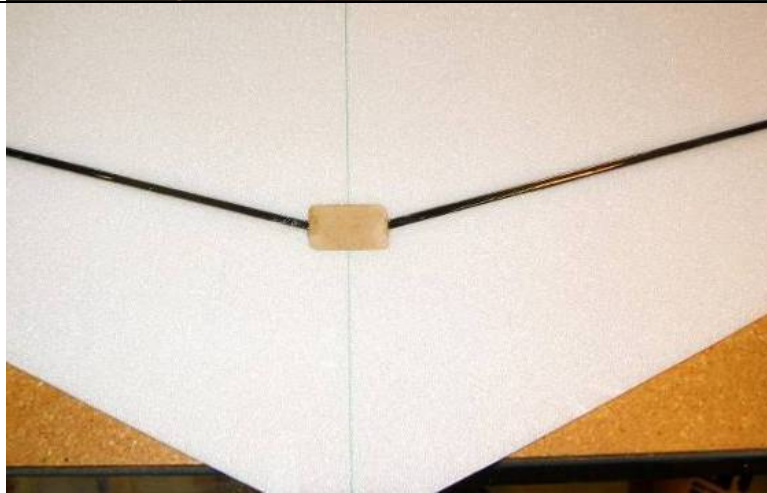

17. Lay the wing down on a flat surface and use 30 minute epoxy to glue the carbon spars in place. Place heavy books over wax paper on top of the wing to hold the wing perfectly flat as the glue cures.

Next cut the flaperons free from the wing. Then cut a 45 degree bevel in the leading edge of the flaperon using a ruler and a hobby knife.

Hinge the flaperon to the wing using your hinge of choice. I used 3M Satin tape on top and bottom, running full span.



18. Test fit the wing strake piece and the wing together on the fuselage. Make sure both line up on the fuselage centerline, and that the strake edges line up with the inlet sides. Trim and adjust if required, and once satisfied with the fit glue both pieces in place using epoxy.

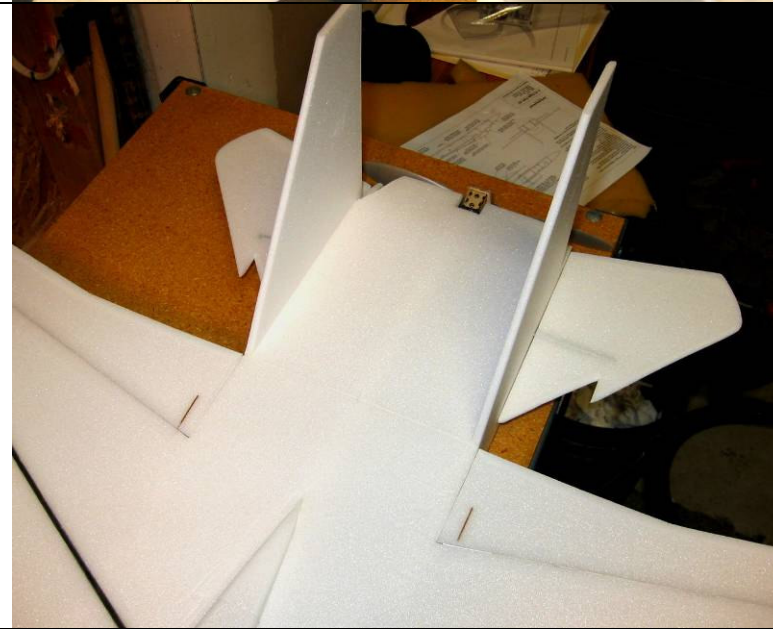

19. Next install the top of the aft fuselage. This piece should be pre-formed with a heat gun to the proper curvature before installation. Note this piece attaches to the tops of the foam support strips that were glued to the fuselage sides earlier.

After the glue is cured, sand the leading and trailing edges of the vertical tails round.

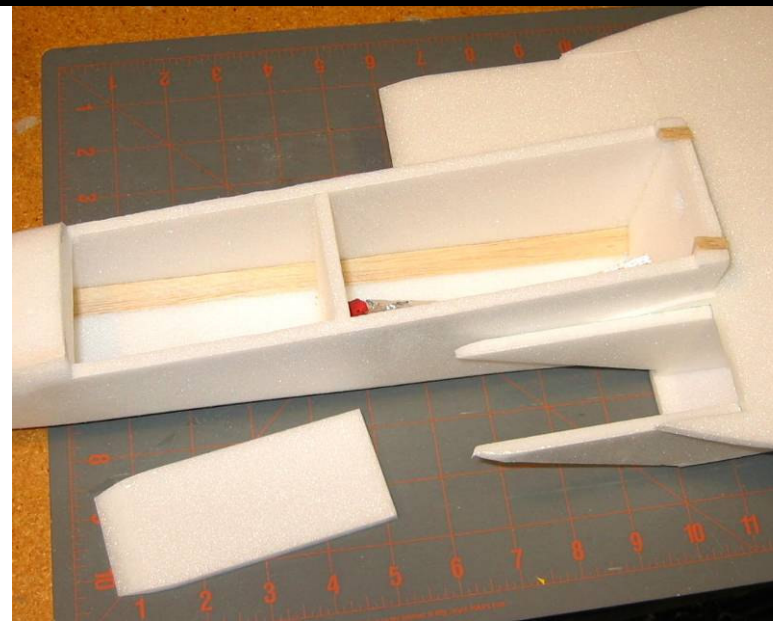

20. Install the forward inlet tops. First cut a long bevel in the bottom leading edge of each piece as shown on the plans. Then glue the pieces in to the tops of the inlet sides and the sides of the wing strake piece.

A view of the completed inlets is shown in the bottom picture.





21. Install the fuselage turtledeck. First glue the turtledeck sides to the top of the wing, taking care to approximate the curvature shown on the plans and to join the ends on the fuselage centerline (drawing a centerline first will help).

After the glue is dry on both sides, glue the turtle deck top piece on.

After that glue dries, sand the corners of the turtledeck round.



22. Cut an access hatch in the turtledeck above the receiver compartment to allow access to the receiver and servo leads. I use small strips of Satin tape to keep this hatch on in flight.

I also recommend applying a single strip of 3M Satin tape around the wing and tail leading edges at this time. The tape helps provide a very smooth leading edge shape and also provides more durability against the inevitable "hangar rash."

If you haven't yet done so, sand all fuselage corners round.



23. OPTIONAL STEP: Parts are provided to make scale-looking engine fairings on the top of the aft fuselage. These parts improve the scale appearance of the model, however, they add 0.3 oz of weight to the aft end of the model—which is often already tail heavy (meaning more ballast has to be installed in the forward fuselage for balance). Thus, the installation of these pieces is at the discretion of the builder. If you're using a high-powered brushless motor and large batteries and aren't so worried about weight and balance, it's fine to install these pieces. But if you're building a lightweight parkflyer and using a smaller motor and battery, you should probably leave these off.

To install these fairings, start by sanding the foam pieces to a rounded top with feathered edges on the sides (see top picture). Then glue in place as shown in the middle picture (note these pieces will need to be gently curved with a heat gun to match the curvature of the fuselage top piece). The bottom picture shows what the model looks like with these pieces installed.

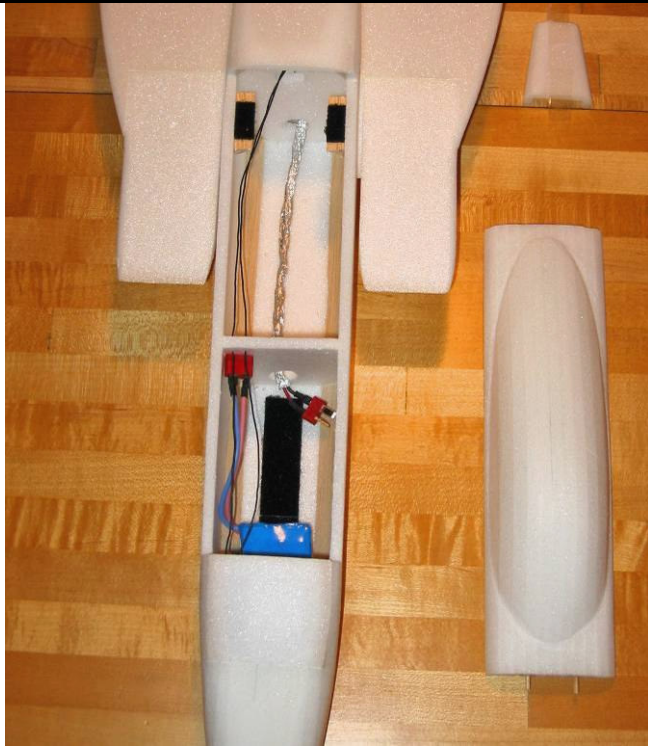

24. The canopy is removable to allow easy access to the battery compartment. It is held in place with two bamboo skewers (or toothpicks) forward that slide into matching holes in the forward bulkhead, and two small strips of Velcro aft that are mounted to short pieces of $\frac{1}{4}$ " balsa triangle stock.

Cut two 2" lengths of bamboo and sharpen both ends. Stick the bamboo into the foam at the front of the canopy so that only $\frac{1}{2}$ " protrudes and glue into place.

After the glue dries, push the canopy onto the airplane so that the protruding ends poke holes into the forward bulkhead. Then glue the Velcro mounts to the fuselage sides as shown on the plans and attach the matching Velcro pieces to the mounts and to the canopy.

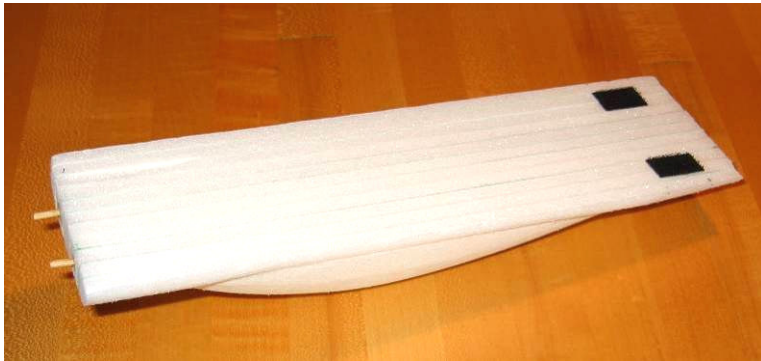

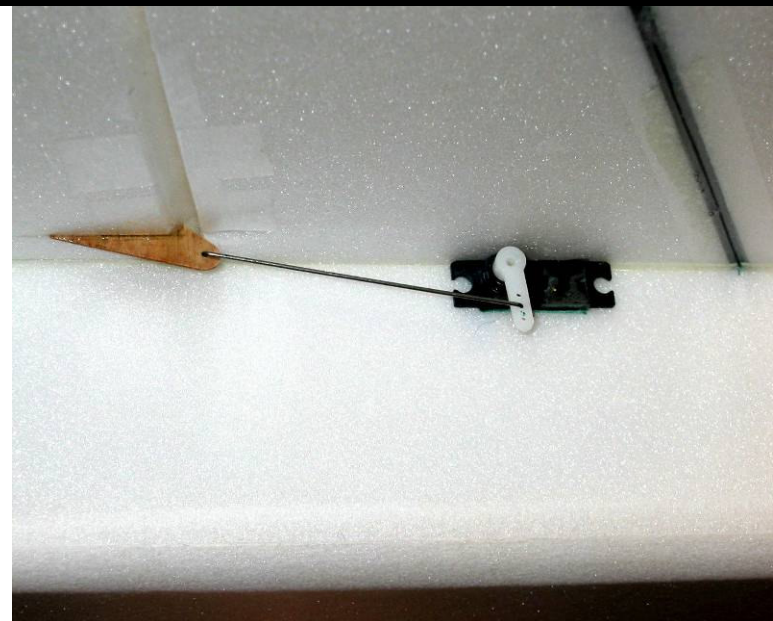

25. Cut holes in the fuselage to fit the flaperon servos tightly, and then install the flaperon servos. The servo is held in place simply by friction (thus it's important to have a tight fit), or alternatively you can use a drop of glue.

Install the flaperon control horns, and make a pushrod from 1/32" music wire (using Z-bends at both ends).

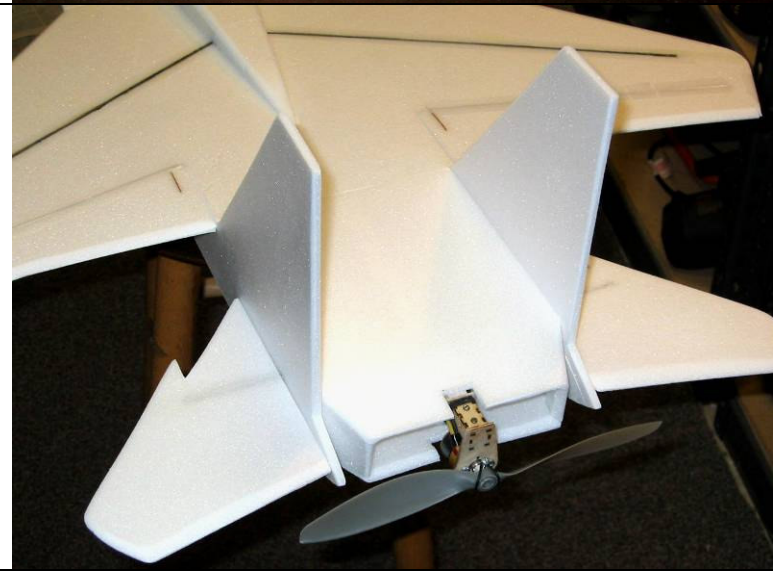

26. Glue in the two exhaust nozzle sides as shown in the photo at left.

Attach the motor to the motor mount. Two screws on top hold the motor onto the wood mounting stick.

Plug the motor into the leads to the speed control.

Note that a "soft-mount" prop adapter is recommended to prevent damage to the prop or the model during landings.

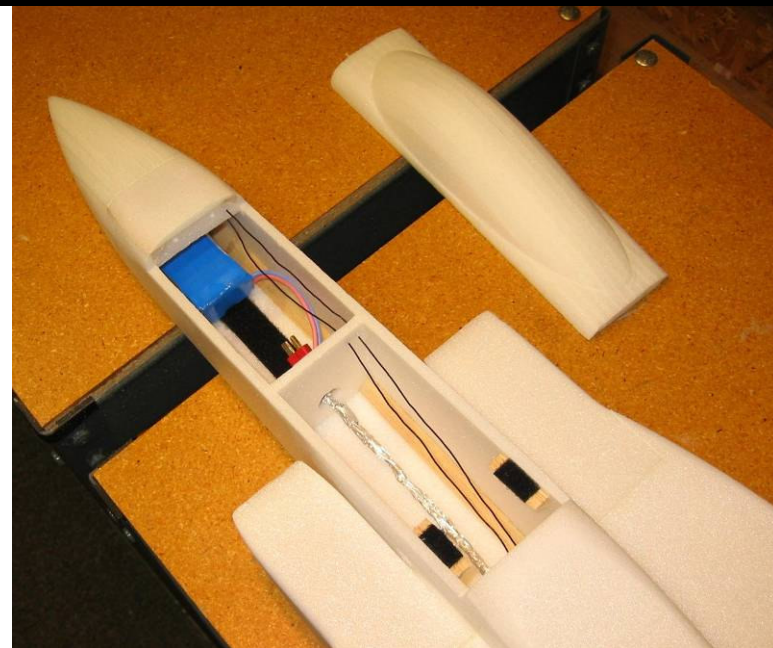

27. Test install the battery inside the forward fuselage to see where it needs to be to provide the correct center of gravity. The prototype model required the battery almost all the way forward. With heavier motor installations, ballast and/or a larger battery pack may be required to balance this model.

After the battery location has been determined, apply a strip of Velcro to the centerline of the fuselage and to the battery. This keeps the battery in place and also allows easily adjusting the center of gravity later.



28. CONGRATULATIONS! Your model is now complete!

The model can be flown as is or can be painted using standard acrylic craft paint (available at most craft stores) applied with either a brush or airbrush. Remember to wipe the foam with rubbing alcohol before painting to remove any grease or dirt. Rough areas such as the canopy and nosecone should be filled with standard wall spackling compound thinned with water, which fills the holes and can be sanded to a very smooth finish (with minimal weight gain).

Additional Photos

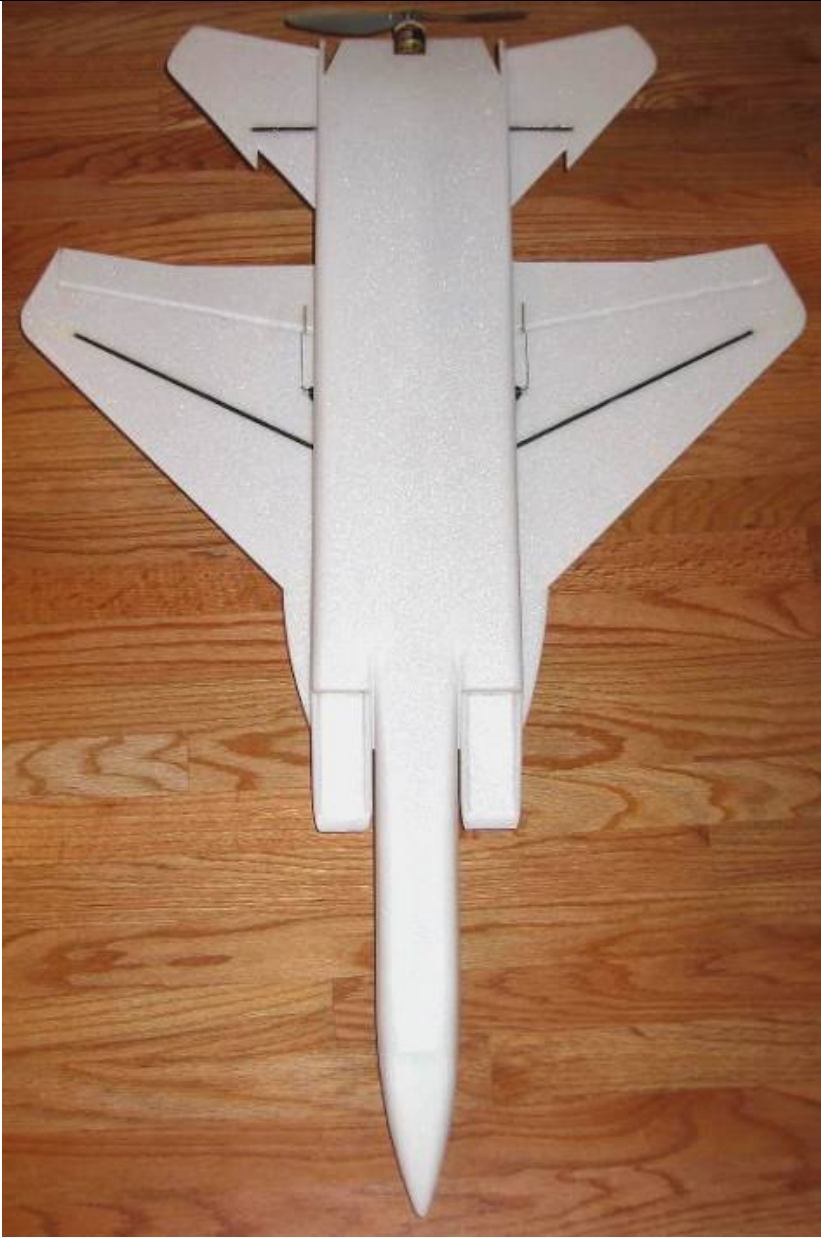

Flight Setup

1. This model flies at it's best with flaperon controls enabled, which requires a transmitter with flaperon mixing. If you don't have one, this model still flies well with ailerons only. The use of flaps can not only improve takeoff and landing performance, but also maneuverability.
2. Adjust the controls to provide the following recommended deflections (all dimensions are measured at the root trailing edge):
 - Stabilators: +/- 2.0"
 - Ailerons: +/- 1.5"
 - Flaps: 0 up, 1.5" down
3. I recommend using -40% exponential rates on elevator and ailerons.
4. Recommended hand launch procedure: Grip the airplane near the CG, set 10 degrees flaps (optional) and 50% throttle, and throw it moderately hard straight ahead and parallel to the ground. **Be careful to keep your hand away from the prop as you throw it!** It's important to launch at only 50% throttle to minimize prop torque effects at launch, which could cause the model to roll left immediately after you throw it.

Slowly add throttle soon after launch, and after the model has gained some speed and altitude retract the flaps if desired. When flying in small fields, the flaps can be left at 10 degrees throughout the flight, which will allow the model to fly slower and turn tighter. If you're flying in a larger field and want faster speeds or better aerobatics, retract the flaps to zero after launch.
5. While landings can be made with no flaps, adding up to 30 degrees flaps before landing really helps slow the airplane down and allows it to float in much easier. You'll find that this model is capable of beautiful slow nose-high landings.
6. **WARNING: Remember to ALWAYS release the elevator control right before touchdown during landings, since the forward stabilator tips can dig into to grass or soft ground—which can significantly damage the model and/or stabilator servo! Also remember to pull the throttle back to zero just before touchdown so that the propeller and/or motor mount is not damaged on landing.**

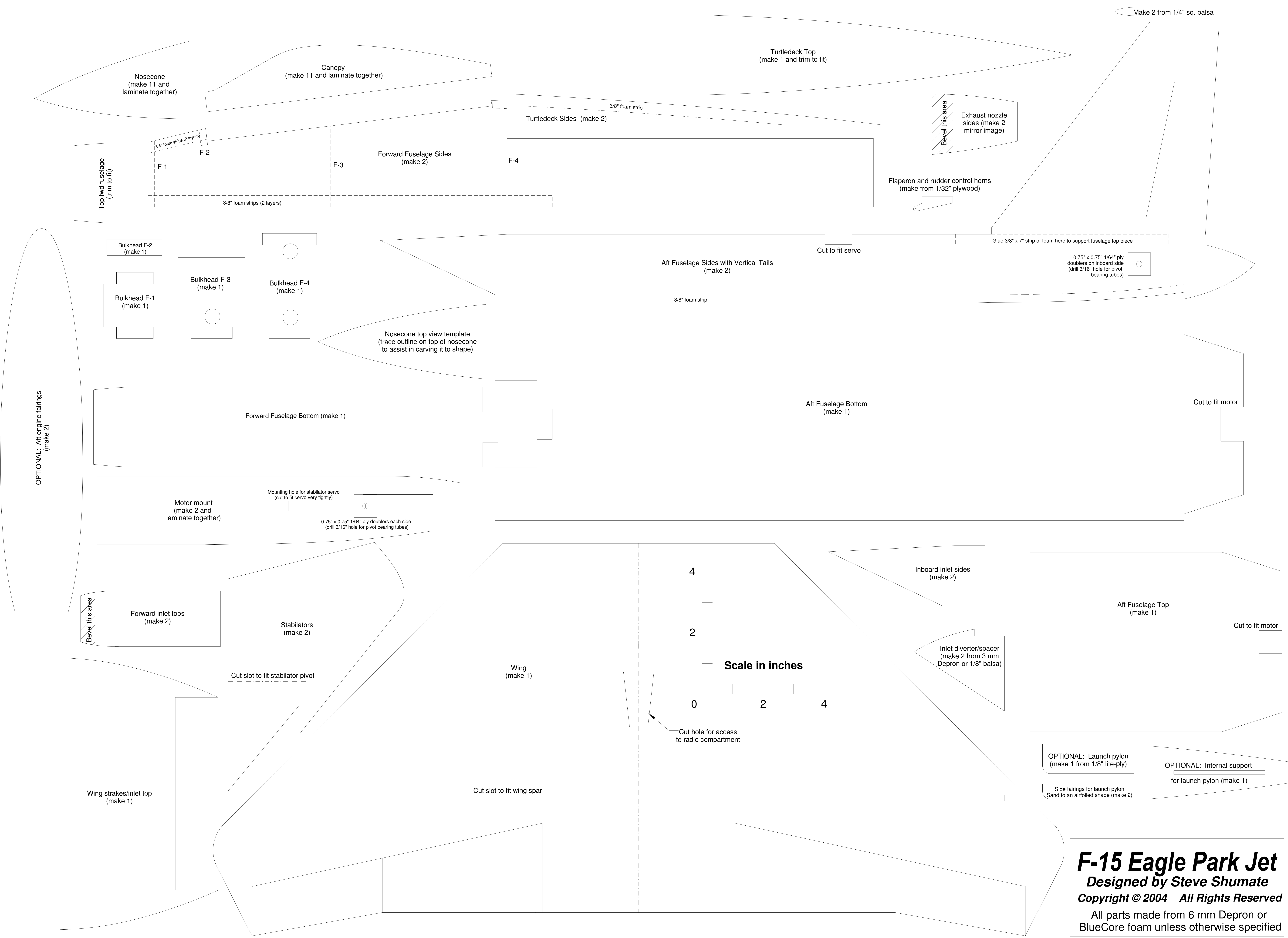

F-15 Eagle Park Jet
 Designed by Steve Shumate
 Copyright © 2004 All Rights Reserved
 All parts made from 6 mm Depron or BlueCore foam unless otherwise specified

NOTES:

- * All parts made from 6mm Depron unless otherwise indicated
- * Use a heat gun to gently bend the foam in the aft fuselage to pre-form it to the shapes shown
- * Sand the wing and empennage leading edges round and apply a piece of 3M Satin tape around the leading edges to add smoothness and durability
- * Recommended control deflections (all dimensions measured at root trailing edge):
 - Stabilators: +/- 2.0"
 - Ailerons: +/- 1.5"
 - Flaps: 0 up, 1.25" down
- * Use -40% exponential rates on elevator and ailerons
- * Choose a power system that provides 15-20 oz static thrust and 45-50 mph pitch speed

Sand fuselage corners round as shown below (not to scale)

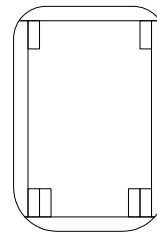

C

RECOMMENDED POWER SYSTEMS:

- 1) Brushed: GWS EPS-350C with C gearing (5.3:1), 8x6 prop, 1200 mAh 11.1V lithium-polymer battery, 10 amp ESC
- 2) Brushless geared: Himax HA2015-4100 with B gearing (4.4:1), 9x6 prop, 1200 mAh 11.1V lithium-polymer battery, 15 amp ESC
- 3) Brushless outrunner: Axi 2208/34 or 2212/26, 9x6 prop, 1200 mAh 11.1V lithium-polymer battery, 15 amp ESC

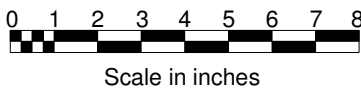
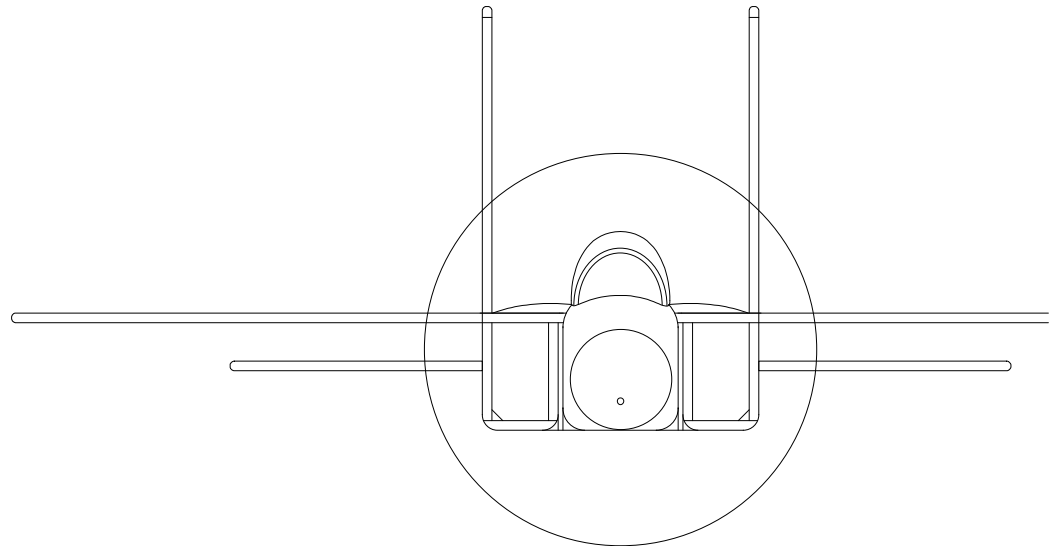
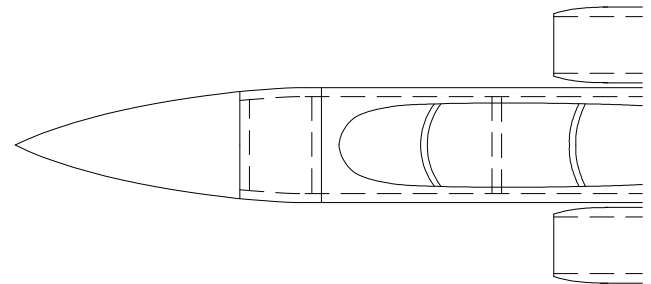

Removable canopy mounted with two bamboo skewers forward and two Velcro strips aft

Canopy and nosecone are made from laminated foam sheets or foam block carved to shape

Battery mounted to fuselage floor with Velcro

Dashed lines indicate foam strip doublers at corners (see parts templates for details)

F-15 Eagle Park Jet

Span: 27.9"
Wing area: 257 sq in
Weight: 15.0 - 18.0 oz RTF
Wing loading: 9.2 oz/sq ft

*Designed and drawn by Steve Shumate
 Copyright © 2004 All Rights Reserved*

