

Sbach 342

By Vincent Posbic

Wingspan: 34 in

Length: 35 in

Weight: TBD

Construction: 6mm Depron, Carbon Fiber tube spars

Equipment used in Prototype

Motor: E-Flite Park 400 920 Kv Outrunner (56 g, 2.0 oz)

Prop: APC E

ESC: E-Flite 20 A Brushless V. 1

Receiver: Hitec Electron 6 (17 g, 0.6 oz)

Servos: Hitec Hs-56HB x 3 (10 g, 0.37 oz or 30 g, 1.01 oz)

Battery: Li-po, 3 cell 1500 mAh

Disclaimer

These plans are offered as a FREE plan, and as such, may not be sold. However, they may be shared, copied, duplicated, etc WITHOUT MODIFICATION.

Introduction

These plans were drawn up at 100% scale in Photoshop and tiled using PosteRazor 1.9.5. The plans are drawn for construction using 6 mm Depron foam, however, other thickness and/or types of foam may be used by adjusting the width of the assembly slots to conform to the foam thickness. The prototype was constructed using 4.5 mm Readiboard® foam from the Dollar Tree with the paper backing removed.

Assembly Instructions

1. Print out the plans, ensuring that the printer settings (Page Scaling) are set to "Shrink to Printable Area", and verify that the zoom is 100%. If the page scaling is set to "Shrink to Printable Area", and the zoom is less than 100%, then the printer's margins are too small for the plans.
2. Tape the plans together, trimming off excess paper where required.
3. Cut out the pieces to use as templates, and trace these templates onto the foam.

4. Cut out the foam pieces, using a new blade for best results. Be sure to cut out two ailerons and two wing pieces. Bevel the leading edges of the ailerons, elevator, and rudder for extreme control surface throws.
5. Glue the two wing pieces to form one full wing.
6. Cut out the channels in the wing and elevator for the carbon rods, and glue the carbon spars with an adhesive of your choice. Spar diameter should be sized according to the thickness of foam used.
7. Cut out slots in the nose of the fuselage and wing pieces corresponding to the size of the motor you will be using.
8. It is most convenient to decorate/paint the pieces now, or you may wait until the plane has been assembled.
9. Slide the fuselage into the wing, and glue together, ensuring that the pieces are at 90° to each other. When dry, epoxy a plywood firewall into the slots cut out earlier.
10. Top hinge the ailerons using packing tape or hinge tape. Do the same for the elevator, and then tape the rudder.
11. Install your radio equipment, the motor, and the ESC. Dual servos or a single servo may be used for the ailerons.
12. Balance and fly!

Enjoy!

Have fun, and be safe!

Layout

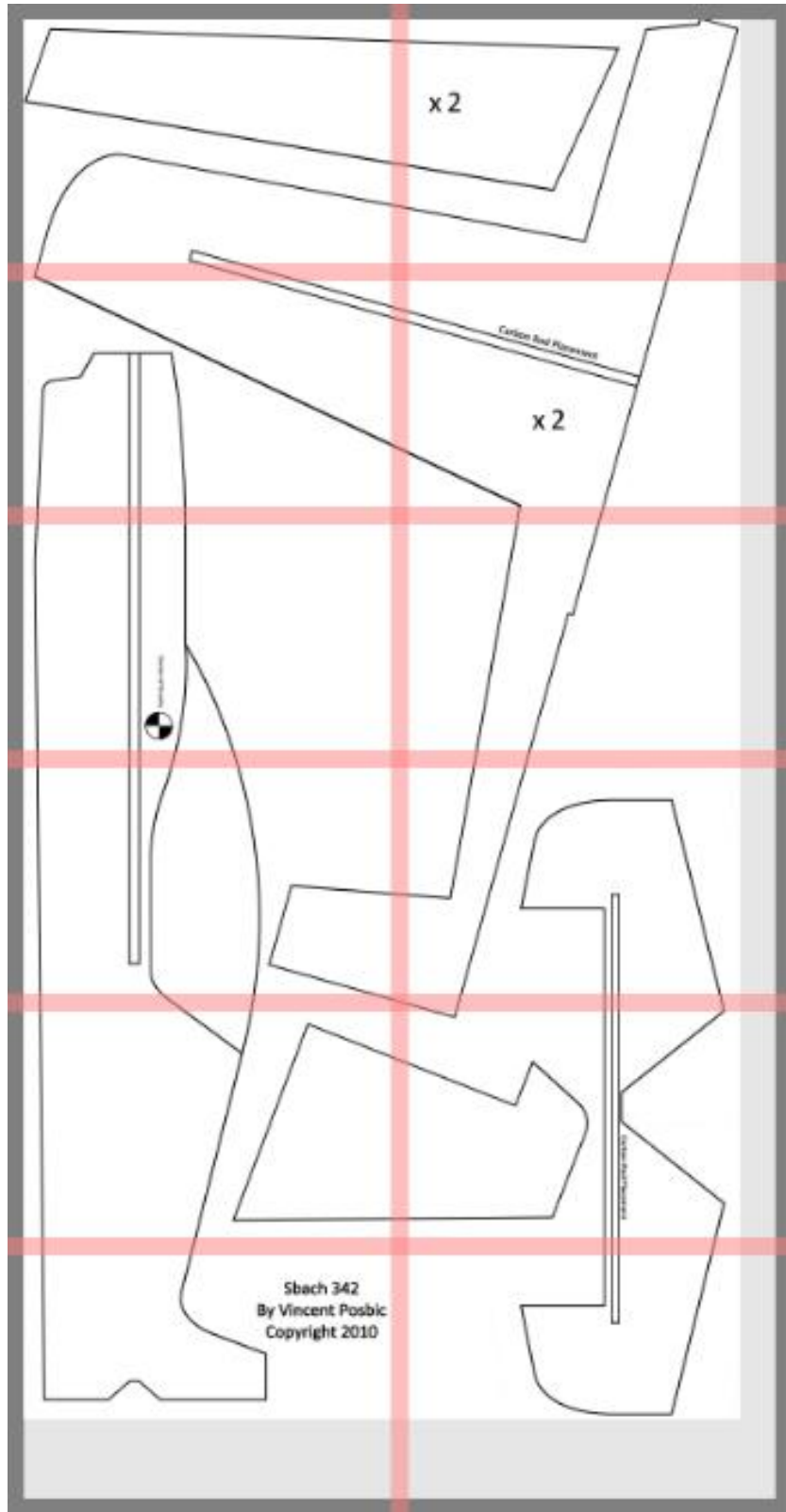

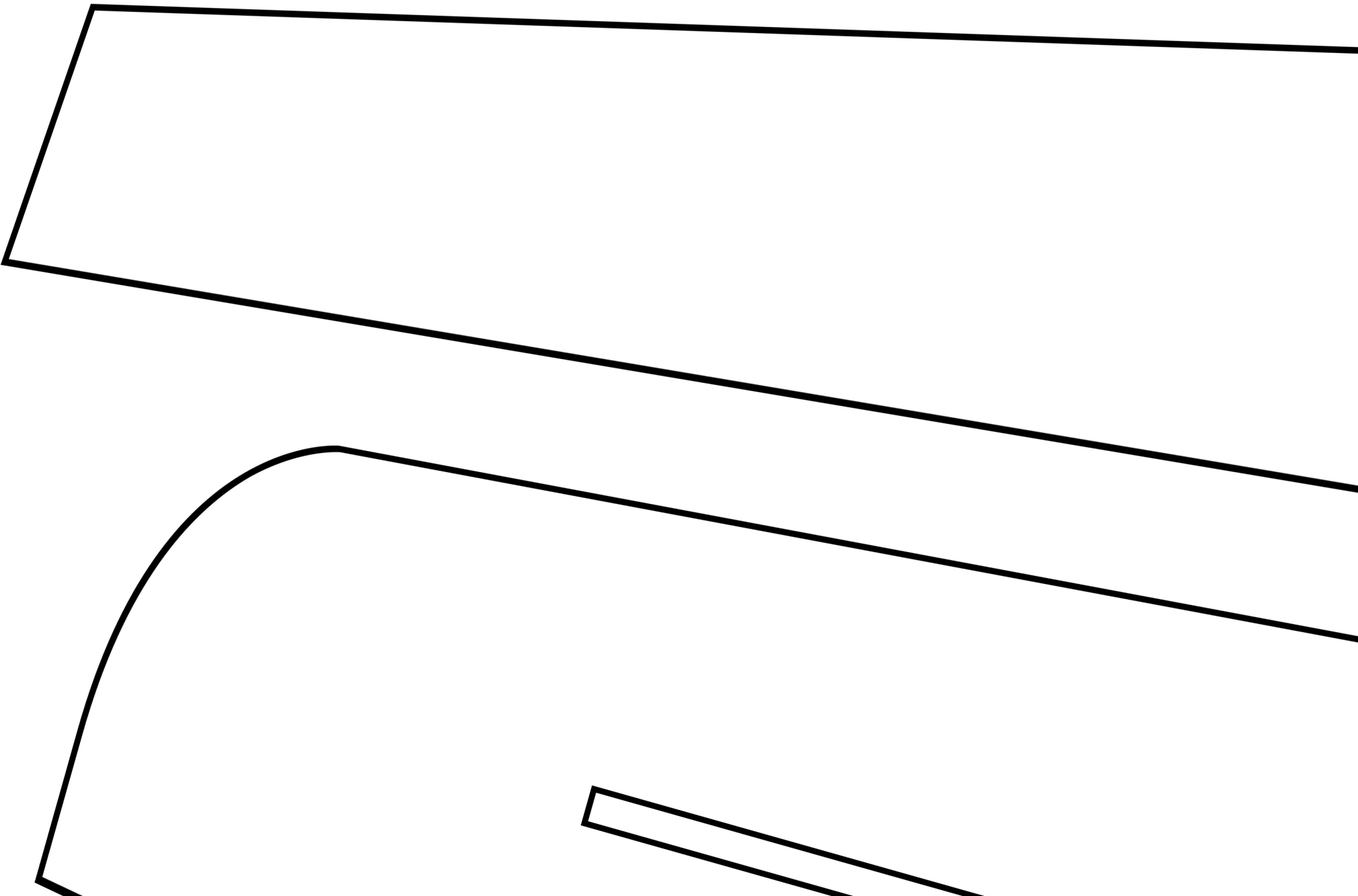



x 2

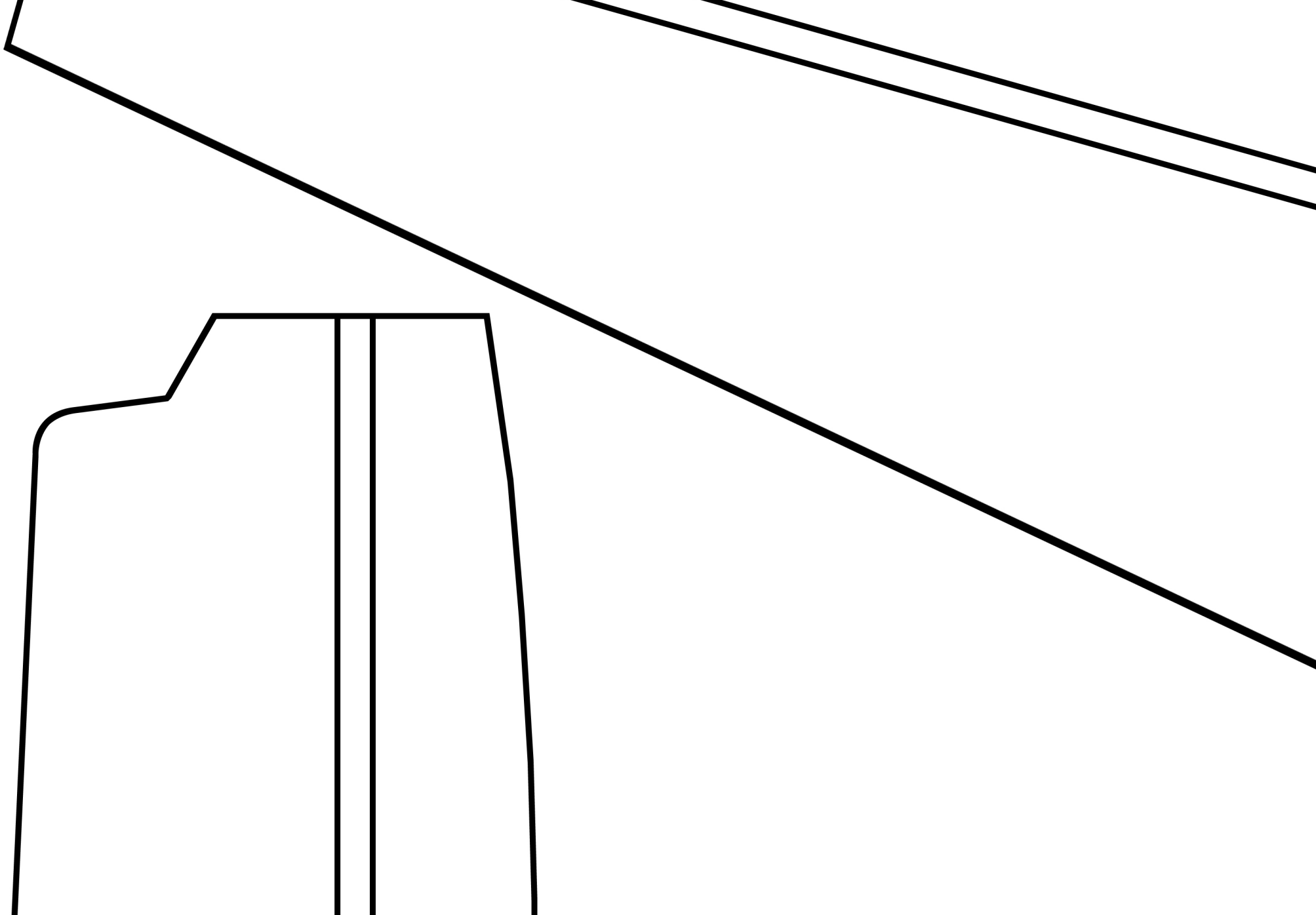



A technical drawing showing a perspective view of a rectangular object. The object is defined by black lines. A horizontal line near the top edge is labeled "Carbon Rod Placement". The text "x 2" is centered within the object's footprint. The drawing is partially cut off on the right and bottom edges.

Carbon Rod Placement

x 2

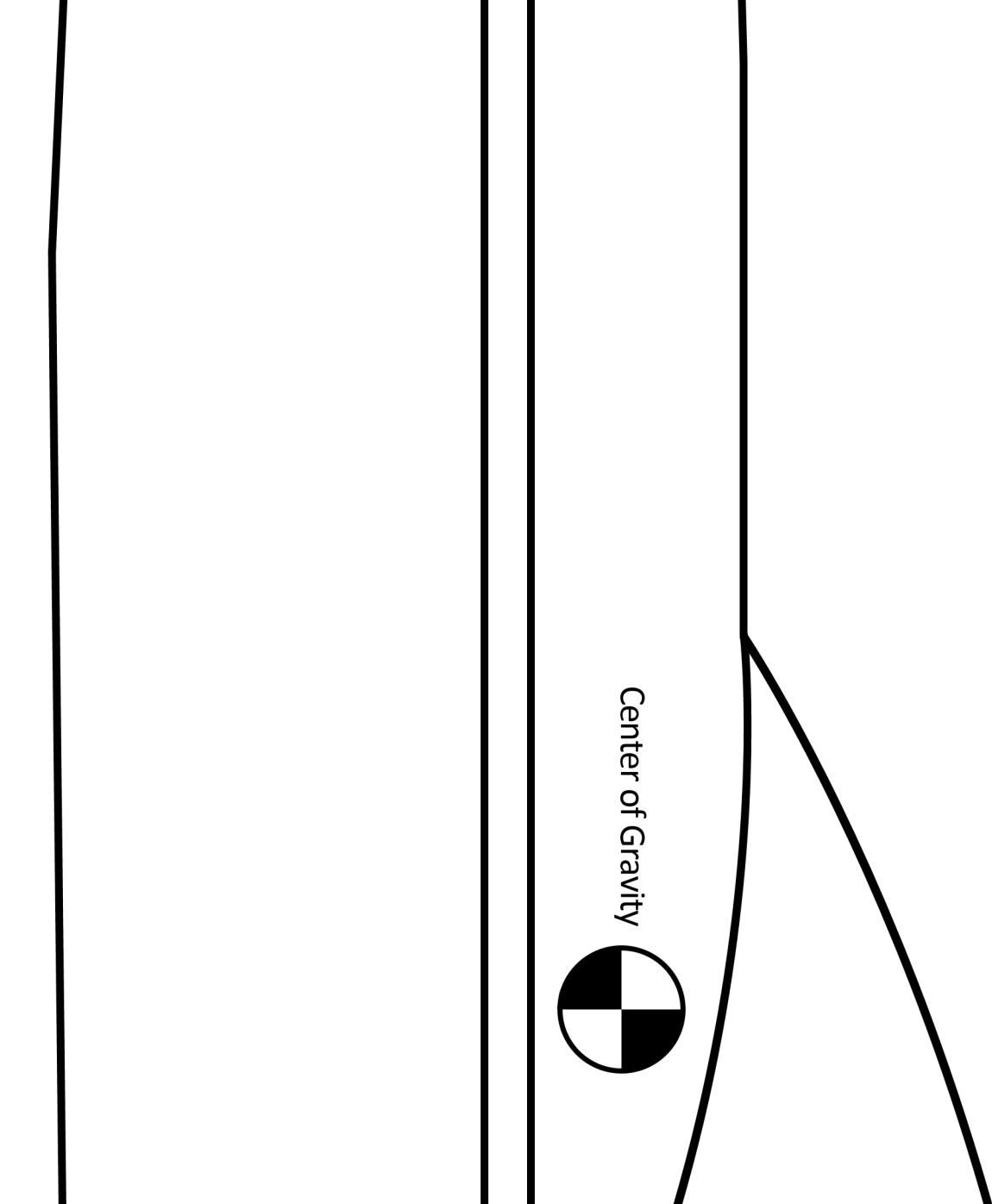

Scale

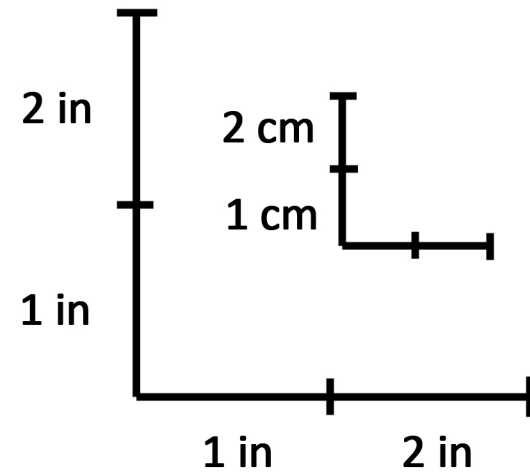

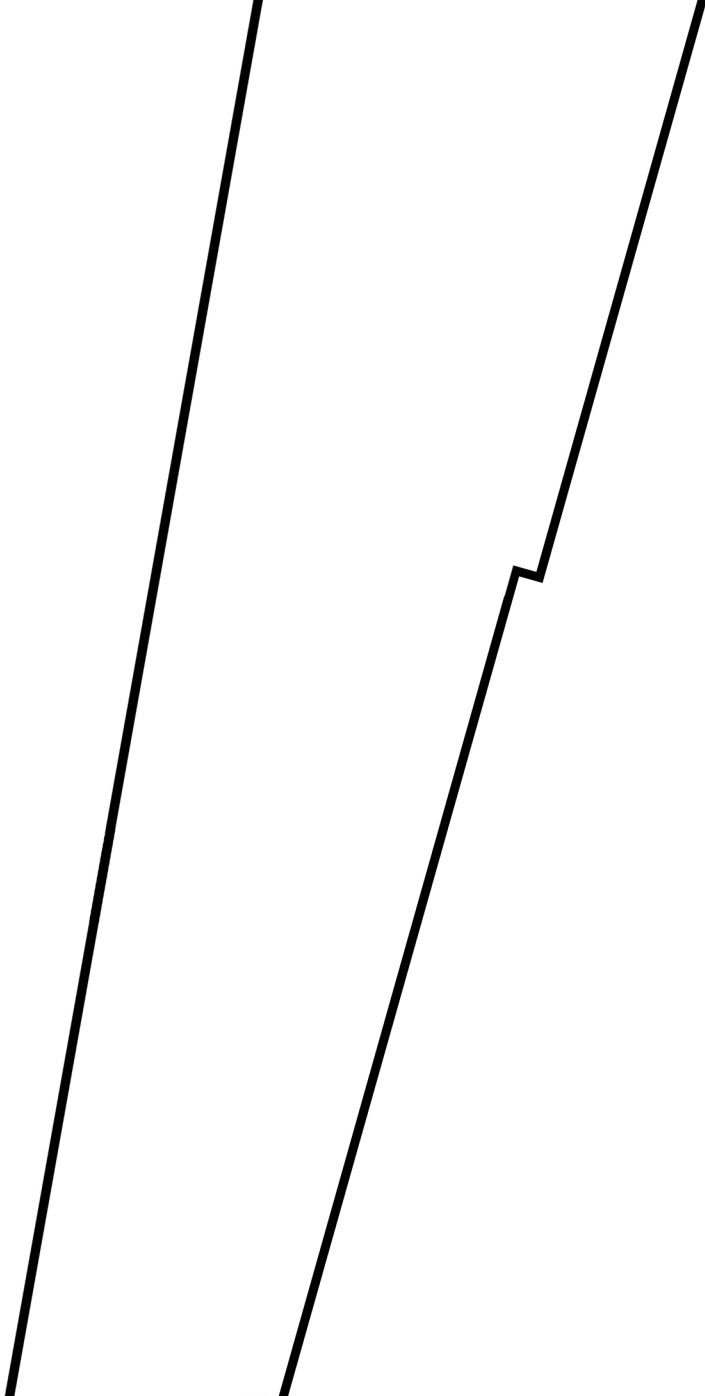

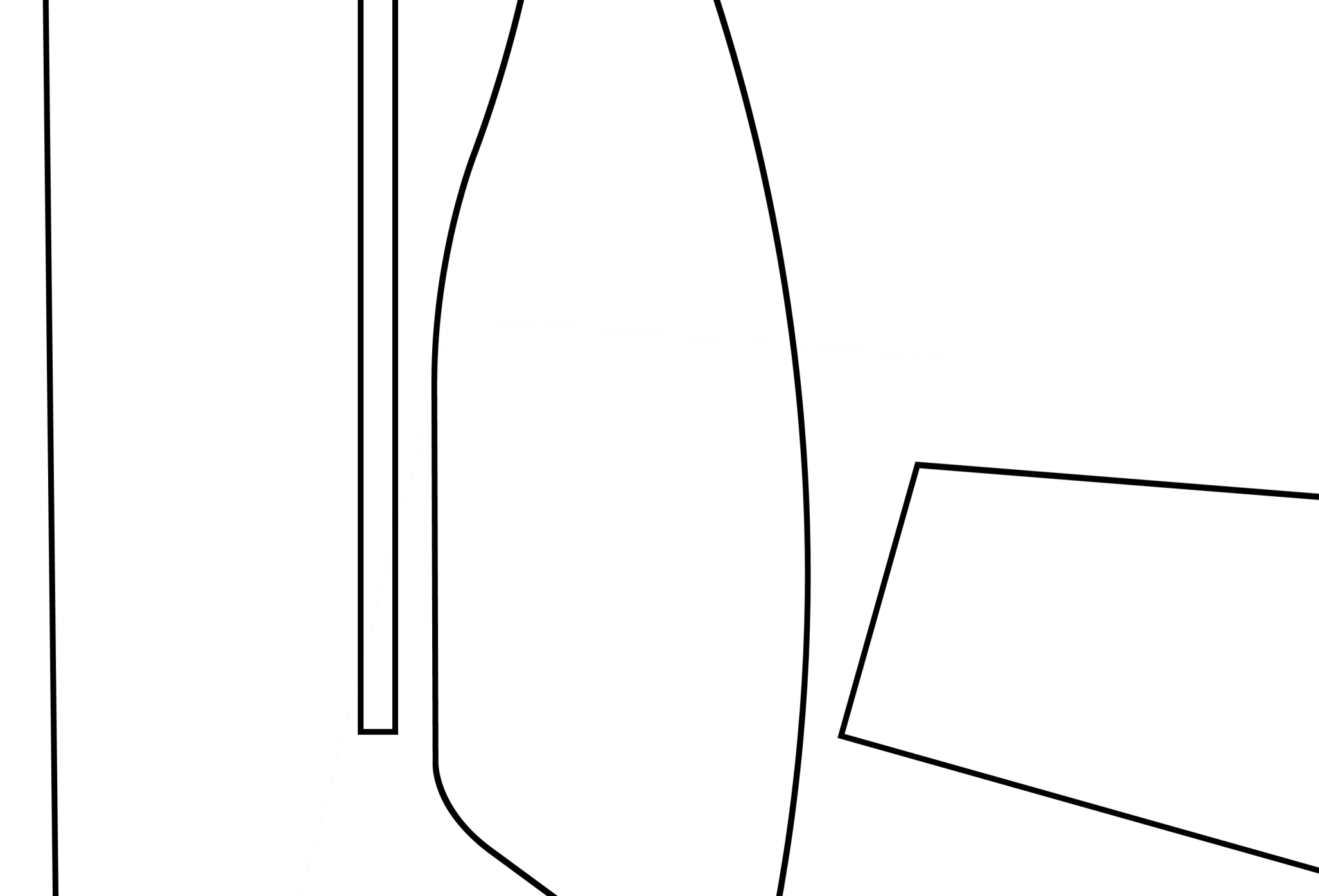

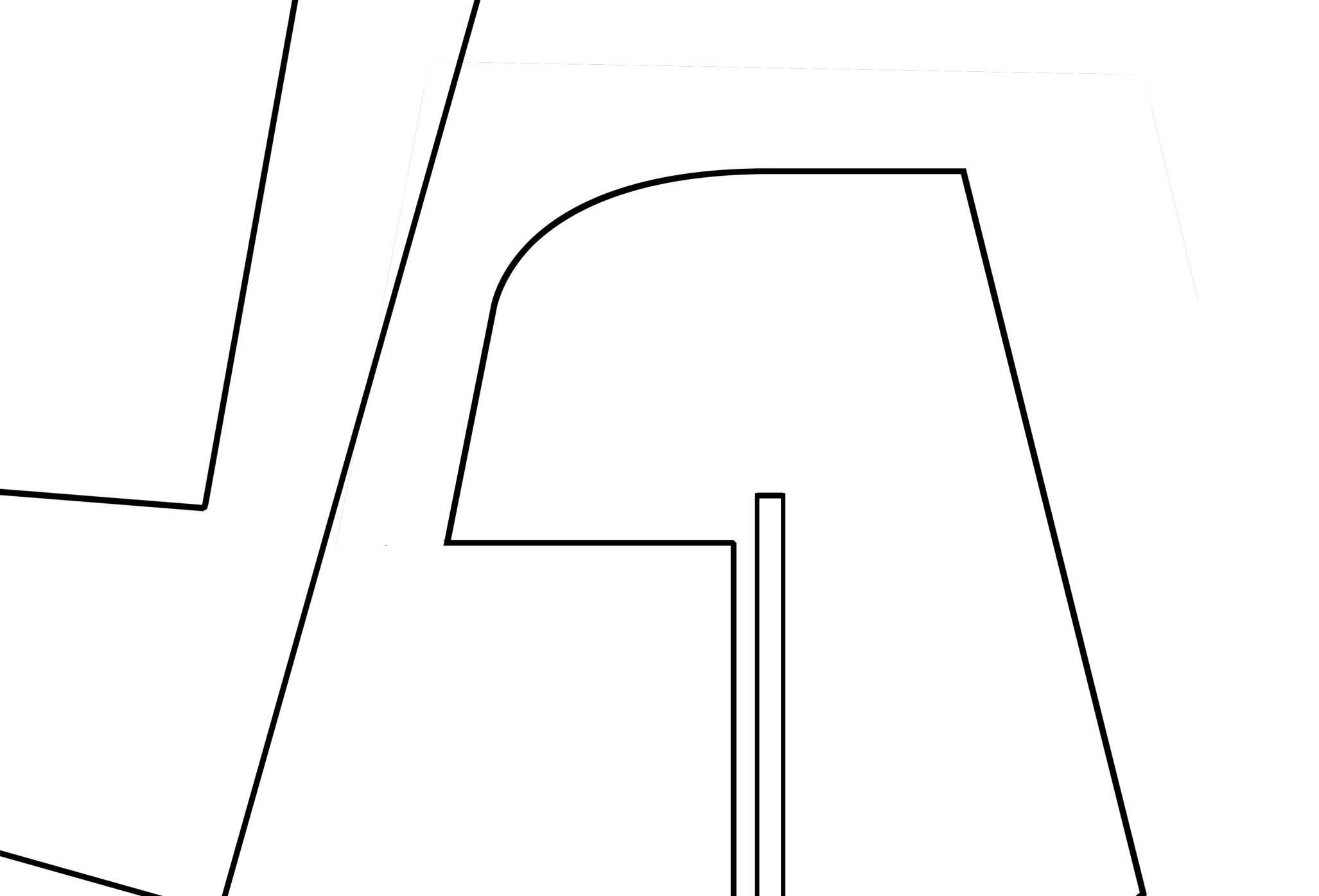

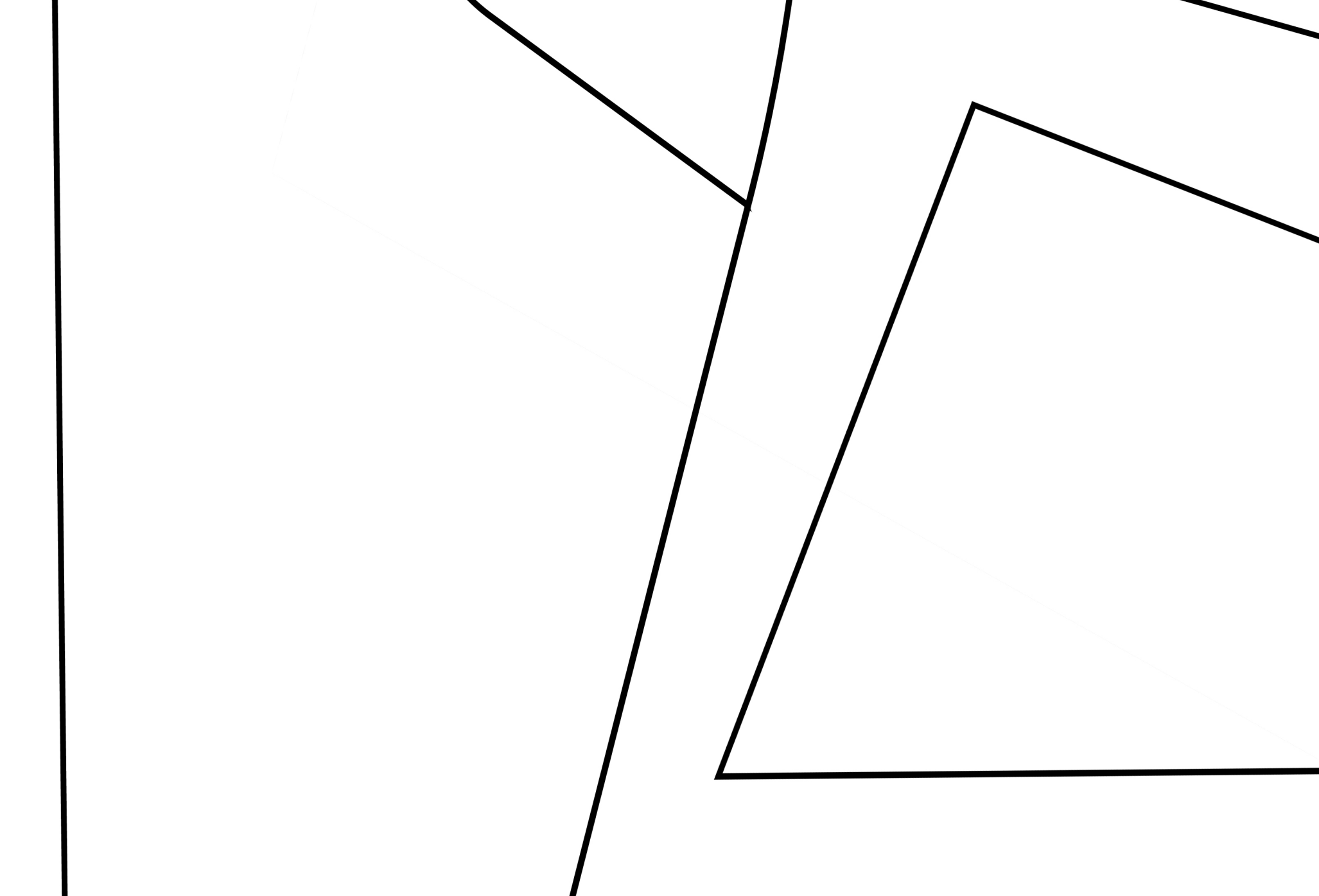

Carbon Rod Placement

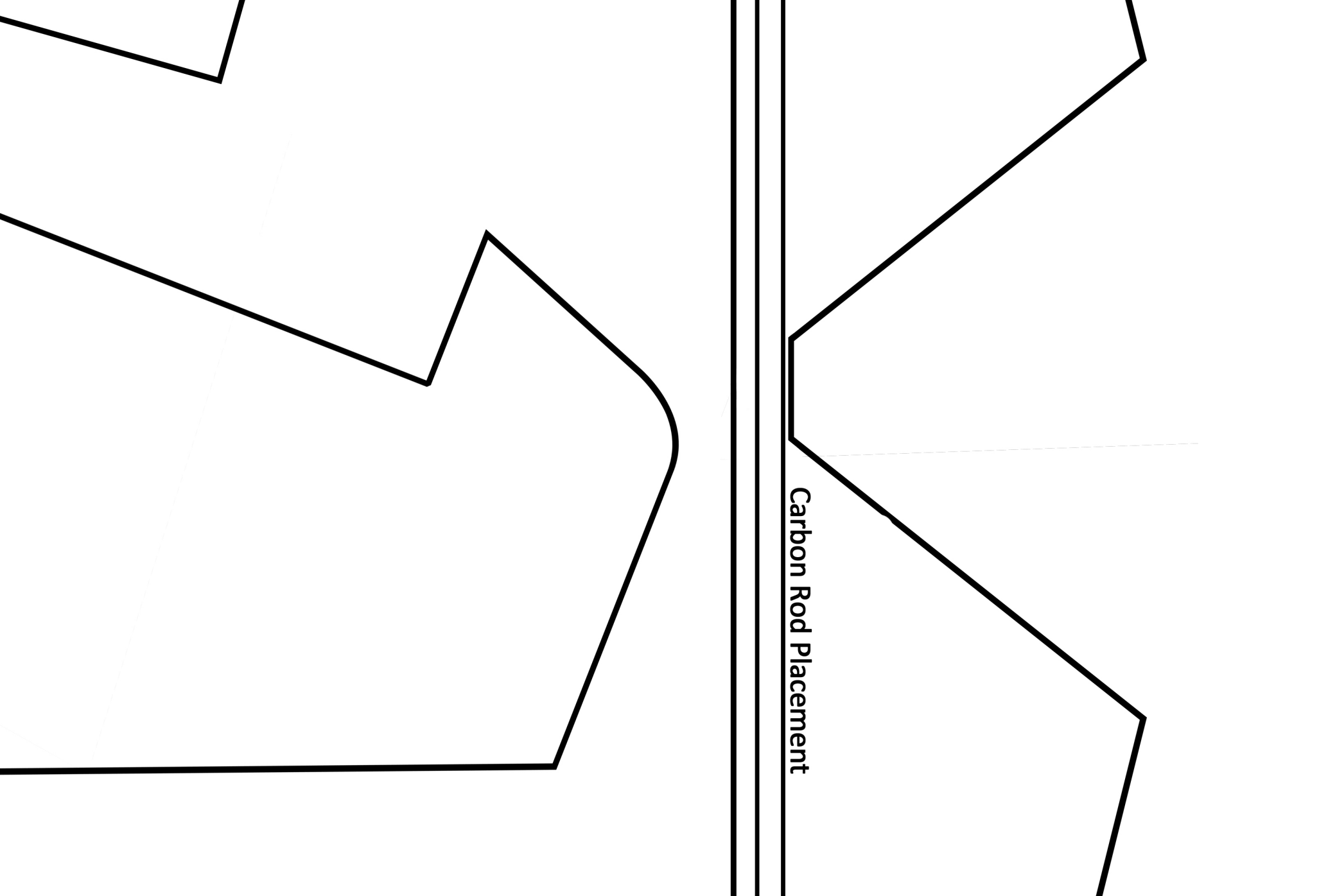

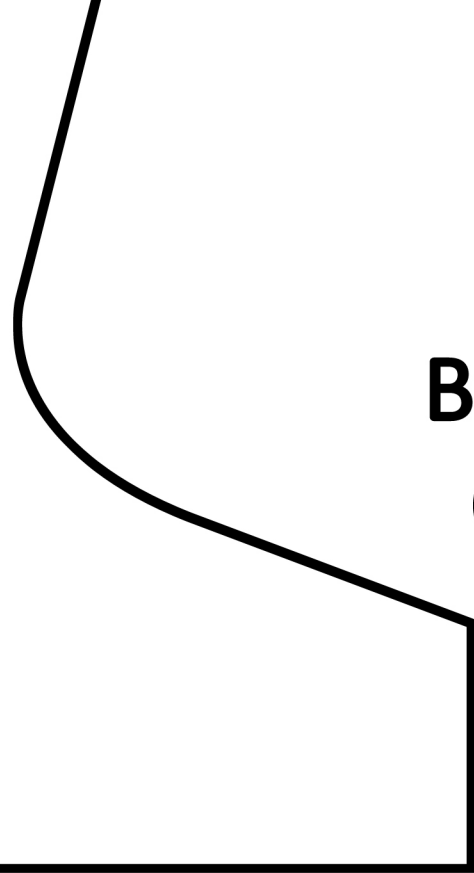

Sbach 342
By Vincent Posbic
Copyright 2010

