

The **ULTIMATE** BIPLANE



Instructions

When Gordon Price is not competing at the World Championships or other full-size aerobatic events, you might find him judging pattern at the Tournament of Champions. Gordon knows high-performance aerobatic airplanes. Feeling that the present crop of competition biplanes could not fully utilize the capabilities of his Ultimate wings he set out to design his own state-of-the-art biplane. With the top model designers he conceived the Ultimate Biplane, at first the 100, then 200, then finally the 300 hp model 10 DASH 300S.

CGP is proud and excited to release Gordon's state-of-the-art biplane as an easy-to-build/exciting-to-fly "typical" Goldberg kit. We kept the generous moments Gordon designed into the full-size Ultimate for its outstanding performance as he demonstrated at the World Championships. The model outline is quite close to scale with minor changes to improve flying characteristics.

The kit is designed around the proven "slot-tab" method of construction, so you will find this the "Ultimately-easiest" biplane to build. Simple built-in fixtures assure warp-free wing assembly. All screws, hardware (including glass-filled engine mounts) etc. are included to finish the airframe.

Formed bolt together aluminum cabanes deliver precise "hassle-free" wing alignment. Full-size plans, and clearly photographed instructions guide you through every step. Also furnished are rugged molded Cowl, Canopy, and wheel parts and two large sheets of full-color decals for the finishing touches of your "Ultimate" model.

WARNING

While this aircraft is an excellent first choice for novice pilots, a radio-controlled model is not a toy and is not intended for persons under 16 years old. Keep this kit out of the reach of younger children, as it contains parts that could be dangerous. A radio-controlled model is capable of causing serious bodily injury and property damage. It is the buyer's responsibility to build this kit correctly and to properly install the motor, radio, and all other equipment. Test and fly the finished model only in the presence and with the assistance of another experienced R/C flyer. The model must always be operated and flown using great care and common sense, as well as in accordance with the Safety Code of the Academy of Model Aeronautics (5151 Memorial Drive, Muncie, IN 47302), 1-800-435-9262). We suggest you join the AMA and become properly insured prior to flying this model. Also, consult with the AMA or your local hobby dealer to find an experienced instructor in your area. Per the Federal Communications Commission, you are required to use only those radio frequencies specified "for Model Aircraft".

CARL GOLDBERG PRODUCTS, LTD.

INTRODUCTION

USING THIS INSTRUCTION MANUAL

Like a full-size airplane, the Extra 300 is built from basic structures; stabilizer, fin, wing, etc. which are then assembled into the complete airplane.

Special procedures or comments will usually be explained before a step so you will be prepared. If a step begins with a statement like "Note," "Warning," or "Important," it is a good idea to read through the step before doing it.

A check-off box appears at the beginning of each step. Check these boxes as you build so you can tell at a glance what steps you have completed.

Some steps require you to repeat them, as in the case of the left and right wing panel. When this occurs circle the check box as you go.

2. Cut the front piece along the scribe line -circumference.

- Cut out the two air intake openings or of the spinner ring along with the bottom of the prop shaft opening. Use a small round up the edges of each intake.

example step

Some of the instructions deal with general procedures. Boxes are not needed for these sections.

HOW TO READ THE PLANS

There are two plan sheets included with this kit. It shows the Fuselage (Body), the Wing and Tail Parts. Everything on the plans are drawn full-size and shape, and how the finished parts all fit together.

The plan is drawn to show the model completely assembled. But this covers up the parts inside or underneath and makes it hard to understand how things fit together. So for clarity, we have drawn some parts as hidden lines, breakaway views, or removed parts entirely.

For example, on the fuselage, we have removed the left side of the completed model to show the details inside the fuselage.

Sometimes we will "break away" a surface to reveal a detail behind or underneath.

Dashed (hidden) lines show details that are hidden behind or under another part or surface.

The model is made from four kinds of wood: balsa, bass, birch, and various plywoods. Each of these woods has its own characteristic End Grain Pattern (as viewed from the end) which has been drawn on the plans. You can easily use these end grain patterns to identify what kind of wood is shown for a part if you are in doubt.

IDENTIFYING PARTS

Parts for the wing are bundled together, likewise, parts for the tail assembly are also grouped. Die-cut plywood and balsa sheets of common sizes are bundled together so they are less likely to be damaged during shipping and handling.

The various screws, hinges, and fittings are packaged in two plastic bags.

HOW TO USE THE PLANS

The plans are used in several ways. The wings, stabilizer, and fin are assembled directly over the plans. Each wood part is matched over its corresponding location printed on the plan and pinned in place. To prevent ruining your plans from gluing your wings, etc. to them, cover the area you are working on with wax paper or plastic kitchen wrap.

Because the fuselage plugs together and is self-aligning, it is not built directly over the plans. As you assemble the fuselage, you will find the plans helpful in identifying parts and how things fit together.

The plans also show how we installed a typical radio, battery and all remaining equipment and hardware needed to complete the model. By referring to the examples shown on the plan you should be able to install your own radio, etc. even if not the same as what is shown on the plan.

PREPARING FOR ASSEMBLY

Set a flat warp-free pinning board on your work bench. Any material that accepts pins such as insulation board, soft plywood, or even dry-wall (sheet rock) will work for this. Important; any warps or bends in the pinning board will result in wings or tail surfaces that are also warped or bent, making your model more difficult to fly. Make sure that the pinning board is flat. Lay a straight edge across the board to check flatness, you may be able to correct a warped board by shimming low areas of the board.

Position the area of the plan you are going to build (stabilizer for example) over the pinning board and tape it in place so plan is flat and wrinkle free.

Lay a sheet of waxpaper or plastic "kitchen" wrap over the stabilizer area to prevent glue from sticking and ruining your plans.

CONSTRUCTION TIPS

If you never assembled a built-up wood model before, this section describes what the plans and instructions are all about and offers some helpful building tips.

Probably the most helpful tip is to always read a few steps ahead. This will help you to plan ahead, and to be aware of what's coming up.

You may find it helpful to empty all of the small parts from the hardware bags into a common container, such as a margarine tub. This will help to quickly find the items at a glance.

When drilling the 1/16" hinge holes into balsa, you may find it easier to twist the drill between your thumb and index finger. This procedure allows more control in positioning the drill on the centermark.

Punch out only the laser cut parts you need as you proceed. This will help you to keep track of parts, especially the small ones.

PARTS IDENTIFICATION

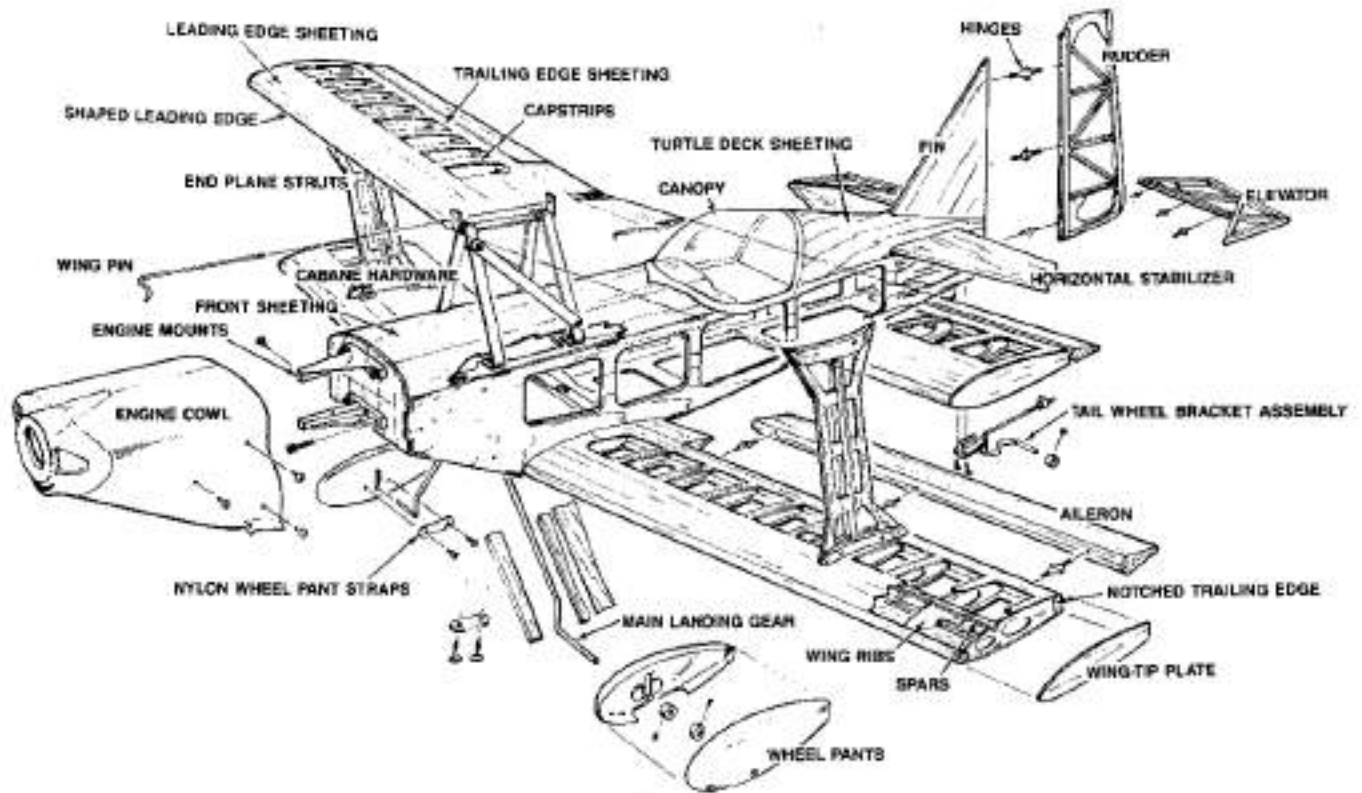

WOOD PARTS

Be careful when removing parts (such as fuselage sides) from die-cut sheets. Long parts are fragile until glued into a structural unit. If necessary, use a razor knife or razor saw to assist in the removal of parts from sheet. Sometimes a little trimming and sanding can improve parts where desired. Save scrap until model is completed, in case you should miss a part. Scrap is used also in some building steps on the plan.

ABOUT THE WOOD IN THE KIT

We strive to supply good quality materials in your kit. Wood parts are inspected with regard to the function they will serve. If an imperfection is spotted in a scrap corner of a die-cut sheet and doesn't affect actual parts, the sheet is considered acceptable. Also, internal stresses in wood are relieved as it is cut into parts. These relieved stresses may cause some parts to bow. Bows in wood parts (such as leading edges) readily straighten out as they are glued into a structural unit.



3/16" x 5/16" x 24"
BALSA (7 REQ'D)



5/16" x 5/16" x 24"
BALSA (4 REQ'D)



3/16" x 3/16" x 18"
BALSA (3 REQ'D)



1/8" x 5/16" x 24"
BALSA (1 REQ'D)



1/8" x 1/4" x 27-3/8"
BASS (8 REQ'D)



1/16" x 1" x 28"
BALSA (8 REQ'D)



SHAPED L.E. BALSA



NOTCHED T.E. BALSA



1/16" x 3/8" x 24"
BALSA (12 REQ'D)



1/2" x 8" TRI STRIP
BALSA (1 REQ'D)



1/8" x 3/16" x 21"
BALSA (3 REQ'D)



1/8" x 1/8" x 18"
BALSA (1 REQ'D)



1/8" x 1/2" x 21"
BALSA (2 REQ'D)



3/16" x 1/2" x 24"
BALSA (1 REQ'D)



AILERON STOCK

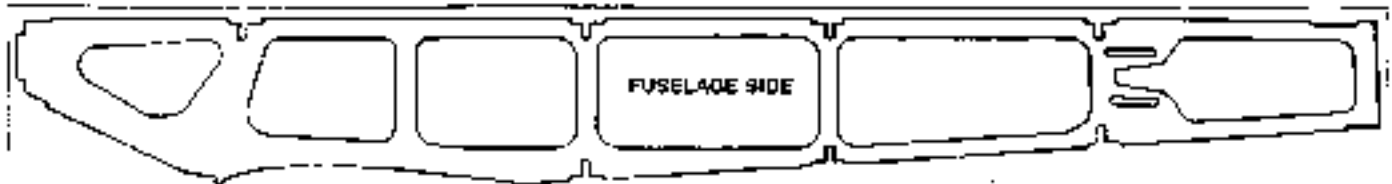

SHEET 5301 (2 REQ'D)

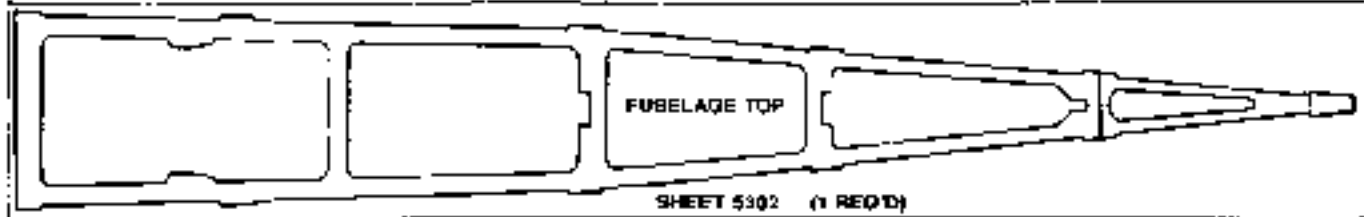

SHEET 5302 (1 REQ'D)

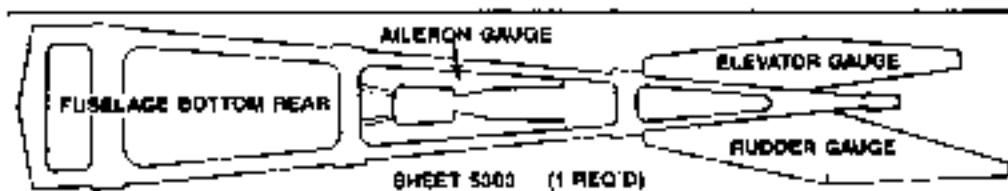

SHEET 5303 (1 REQ'D)

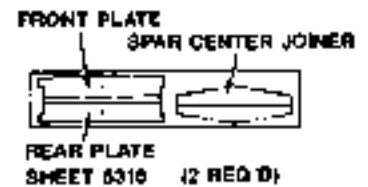

SHEET 5310 (2 REQ'D)

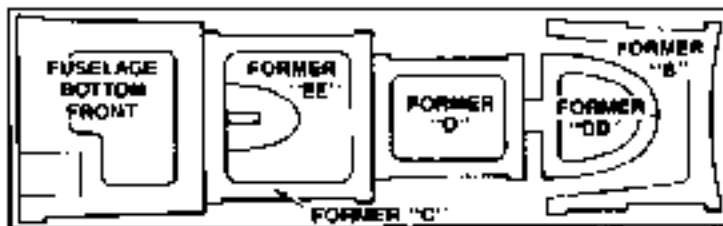

SHEET 5304 (1 REQ'D)

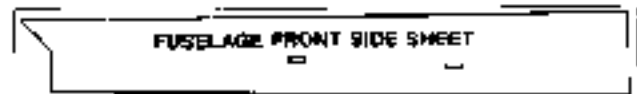

SHEET 5305 (2 REQ'D)



SHEET 5307 (1 REQ'D)

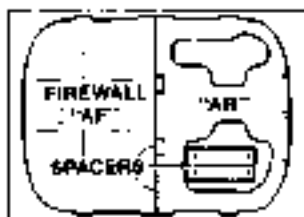

SHEET 5306 (1 REQ'D)

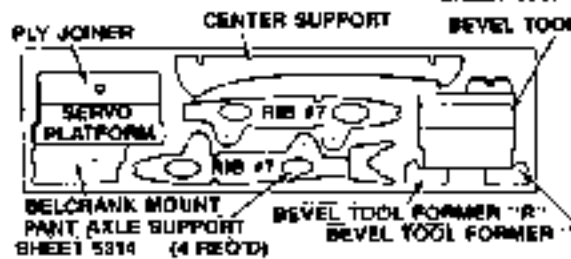

SHEET 5314 (4 REQ'D)



SHEET 5309 (2 REQ'D)

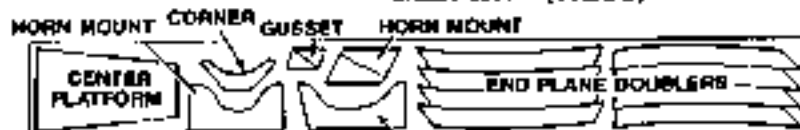

SHEET 5310 (1 REQ'D)

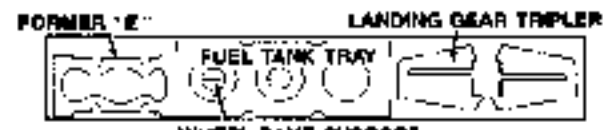

SHEET 5317 (1 REQ'D)

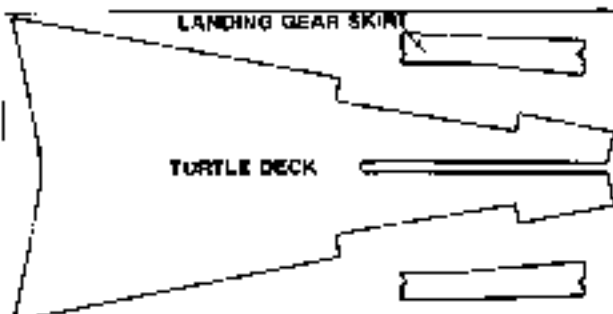

SHEET 5311 (1 REQ'D)

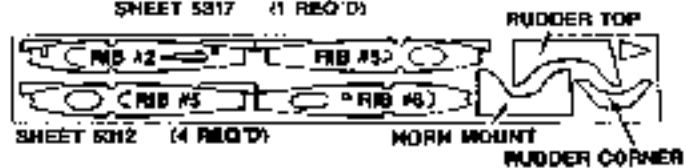

SHEET 5312 (4 REQ'D)

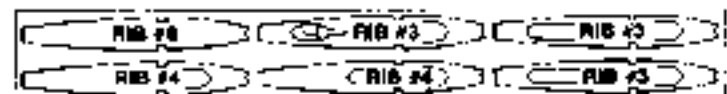

SHEET 5313 (4 REQ'D)



EXIT SHEET

WING END PLATE

SHEET 5315 (4 REQ'D)



SHEET 5305 (1 REQ'D)

SHEET 5316 (1 REQ'D)

HORIZONTAL STABILIZER CONSTRUCTION

(6 Steps)

3/16" x 5/16" Balsa

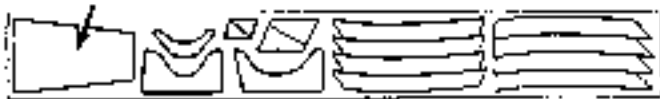

5310

PR#277

1. Find all the parts that you will need to build the HORIZONTAL STABILIZER.

THEY INCLUDE:

- (4) 3/16" x 5/16" x 24" Balsa
- (4) 1/16" x 3" x 21" Balsa
- (1) CENTER PLATFORM Balsa
(DIE SHT. #5310)

2. Items needed for construction:

THEY INCLUDE:

- (1) SHEET OF WAXED PAPER, 24" LONG
- (30) T-PINS
- (1) X-ACTO KNIFE W/#11 BLADE
- (1) RAZOR SAW
- (1) SANDING BLOCK W/FINE SANDPAPER

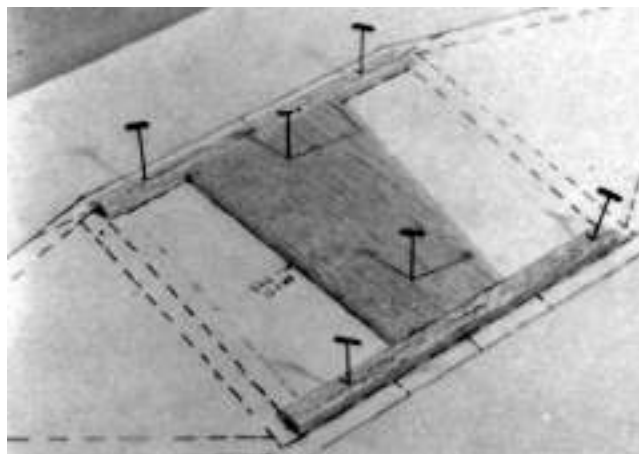

3. Lay the stab portion of sheet 2 of the plan over your building board.
 Lay the waxed paper over the stab on the plan.
 Pin the D.C. CENTER PLAFFFORM over the plan.
 Cut two 3/16" x 5/16" balsa sticks and JET glue to the center platform, pinning over the plan.

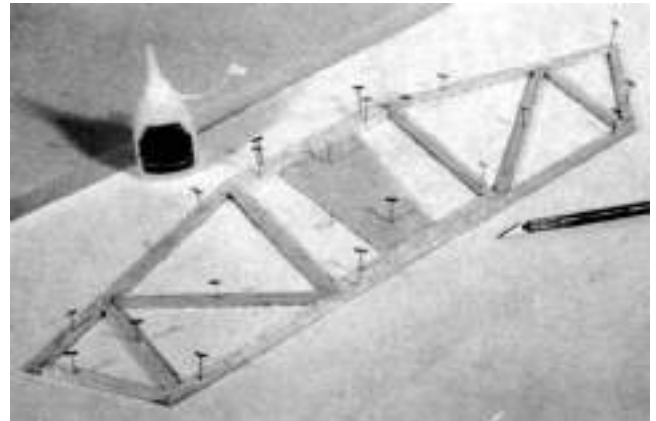

4. Trim the remaining 3/16" x 5/16" balsa sticks to fit the plan, pinning and gluing as you go.

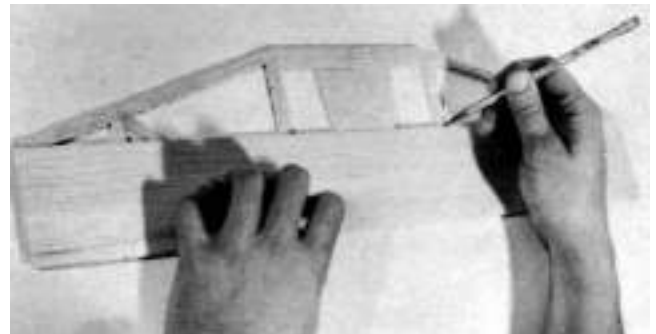

5. Flush an edge of a 1/16" balsa sheet to the trailing edge (T.E.) of the stab and mark the sheet width onto the stab sticks.

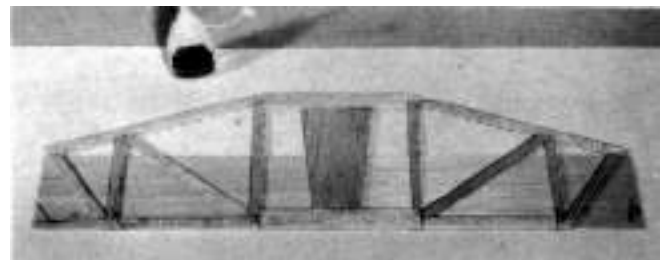

- Remove the sheet and apply JET glue to the stab sticks up to the sheet width mark

- Place the glued stab frame over the 1/16" sheeting, on a flat surface. Make sure that the trailing edge is flush with the sheet.

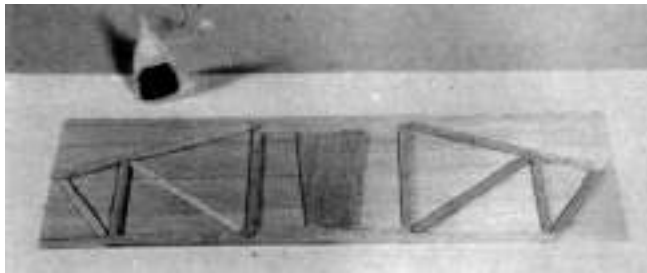

Glue the remaining stab frame and install another 1/16" balsa sheet.



Trim the sheeting to the profile of the stab.

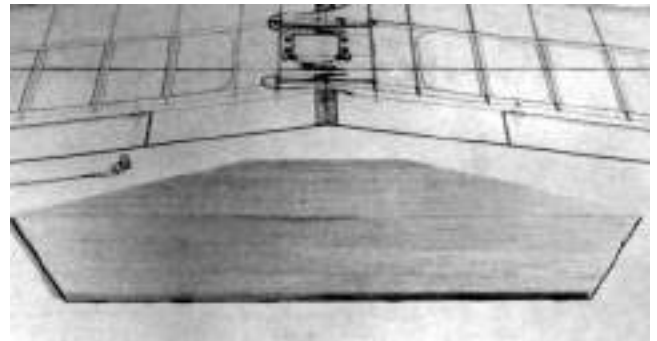

6. Flip the stab over and repeat step 5.

THIS COMPLETES THE HORIZONTAL STABILIZER, PUT IT ASIDE FOR NOW, YOU WILL NOT NEED IT UNTIL YOU HAVE COMPLETED THE ELEVATORS AND ARE READY TO INSTALL THE HINGES.

ELEVATOR CONSTRUCTION (6 Steps)

Note: A left and a right elevator is required. The same plan is used twice to accomplish this.

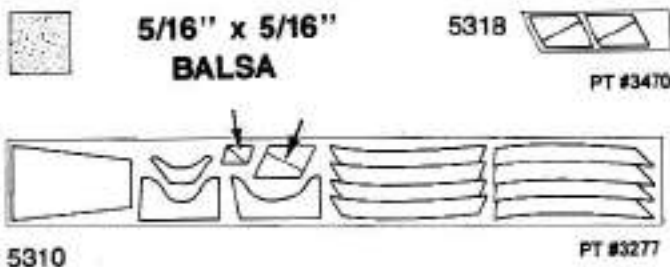

1. Find all the parts that you will need to build the ELEVATOR HALVES.

THEY INCLUDE:

- (2) 5/16" x 5/16" x 24" Balsa
- (4) HORN MOUNTS PLY (DIE SHT. #5318)
- (2) HORN MOUNT CORES Balsa (DIE SHT. #5310)
- (2) GUSSETS Balsa (DIE SHT. #5310)

2. Laminate the two D.C. PLYWOOD HORN MOUNTS to the 3/16" D.C. Balsa CORE. Make one assembly for each elevator half.

3. Lay waxed paper over the elevator.

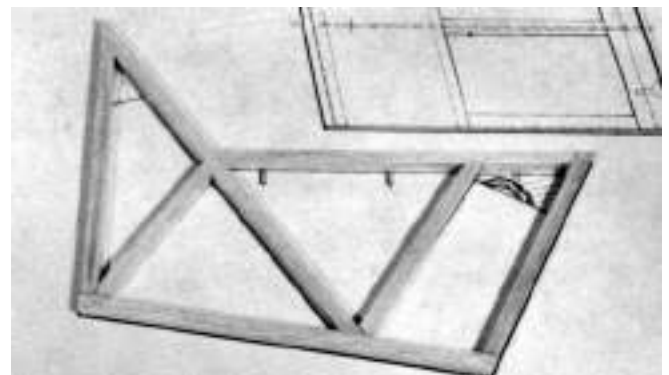

4. Trim and JET glue the 5/16" sq. balsa sticks over the plan, pinning them as you go.

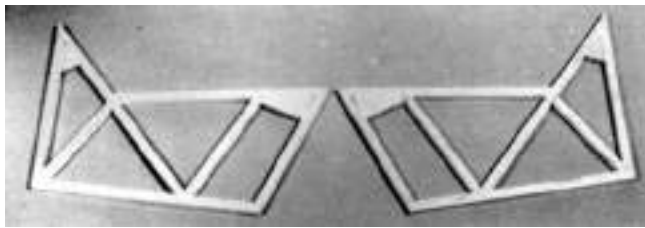

5. Glue the **HORN MOUNT ASSEMBLY** and the **CORNER GUSSET** into the frame.
6. Remove the finished assembly and repeat steps 4 & 5 to build the other elevator half.

VERTICAL FIN CONSTRUCTION (5 Steps)

1. Find all the parts that you will need to build the **VERTICAL FIN**.

THEY INCLUDE:

- (2) 3/16" x 5/16" x 24" Balsa
- (2) 1/16" x 3" x 21" Balsa
- (1) 3/16" SQ. x 18" Balsa

- 3/16" x 5/16" Balsa
- 3/16" x 3/16" Balsa

2. Lay the fin portion of the plan (sheet 1) over your building board.
- Lay waxed paper over the fin plan.

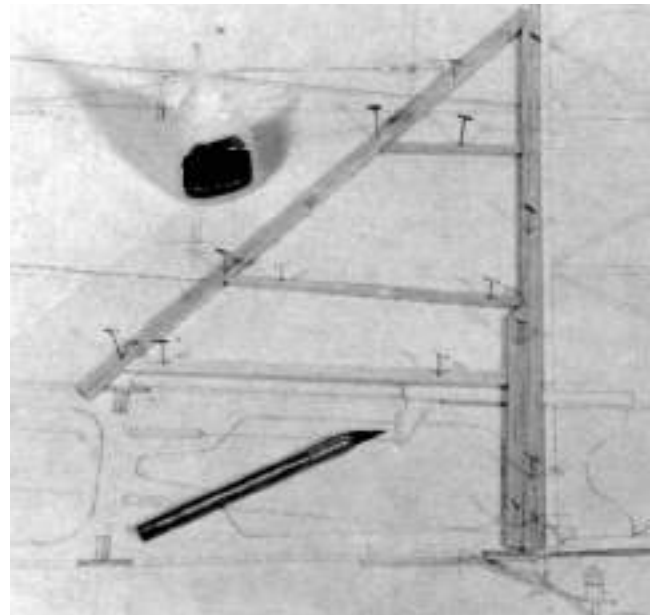

4. Trim-to-fit and glue the 3/16" x 5/16" fin-base and L.E. along with the two 3/16" x 3/16" fin ribs.

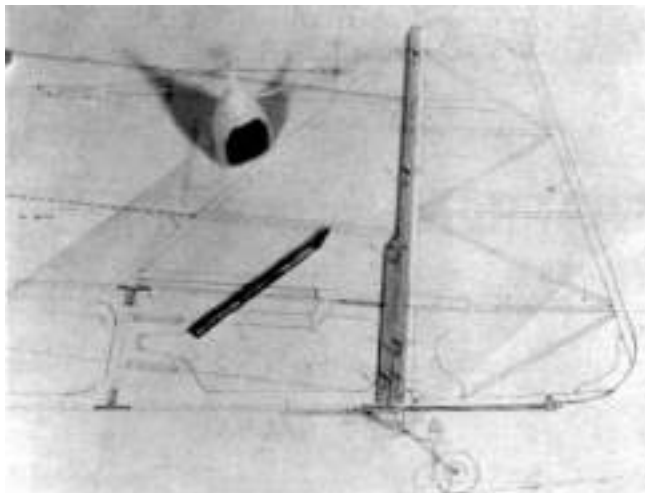

3. Cut the 3/16" x 5/16" **RUDDER POST** to length and pin to the plan.
- Trim and glue the 3/16" x 5/16" **DOUBLER** to the post.



5. With the 1/16" sheeting flush to the L.E., mark the other edge onto the frame.

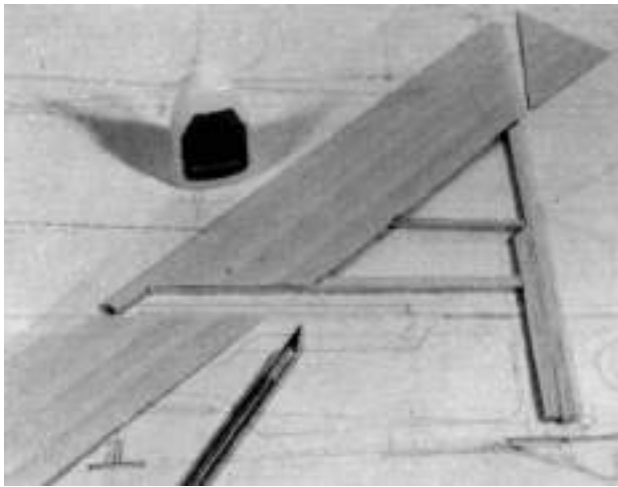

Apply JET glue on the frame, up to the marks and permanently install the sheeting. Pin down to insure a flat assembly.

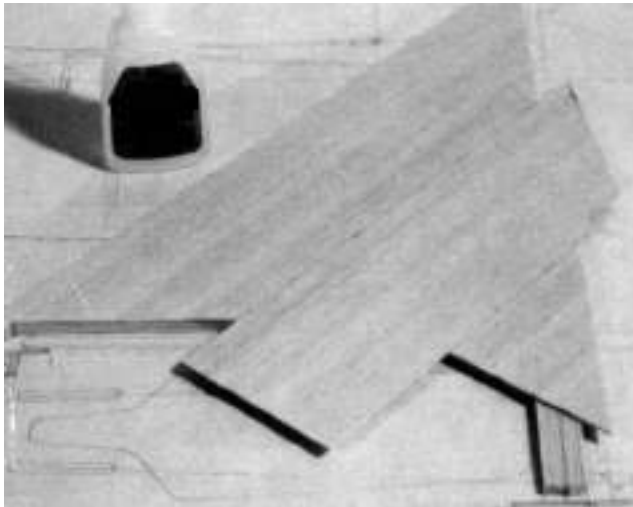

Trim the sheet and use the drop-off to cover the remaining fin side, trimming to the profile of the fin as you go.



CAUTION: TRIM THE SHEETING ONLY!

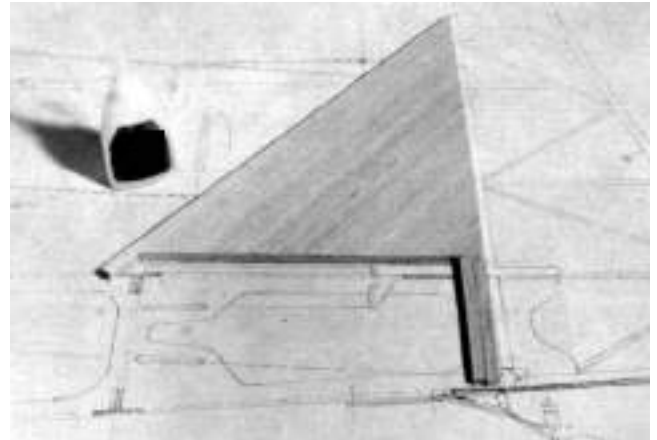

6. Flip the fin over and repeat step 5 to complete the fin sheeting.



THIS COMPLETES THE VERTICAL FIN CONSTRUCTION. PUT IT ASIDE FOR NOW, YOU WILL NOT NEED IT AGAIN UNTIL YOU INSTALL THE HINGES.

RUDDER CONSTRUCTION (4 Steps)

1. Find all the parts that you will need to build the RUDDER.

THEY INCLUDE:

- (2) 5/16" x 5/16" x 24" Balsa
- (1) 3/16" x 5/16" x 24" Balsa
- (1) 1/8" x 5/16" x 24" Balsa
- (1) 3/16" D.C. Balsa Rudder Top
- (2) 1/16" D.C. Balsa Rudder Top
- (1) 3/16" D.C. Balsa Rounded Corner
- (2) 1/16" D.C. Balsa Rounded Corner
- (1) 3/16" D.C. Balsa Horn Mount
- (2) 1/16" D.C. Balsa Horn Mount

-  5/16" x 5/16" Balsa
-  3/16" x 5/16" Balsa
-  1/8" x 5/16" Balsa

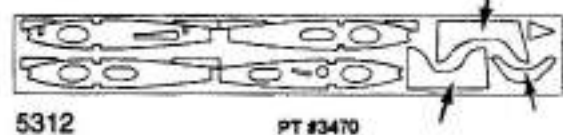

2. Lay the rudder portion of the plan over your building board.
- Lay waxed paper over the plan.

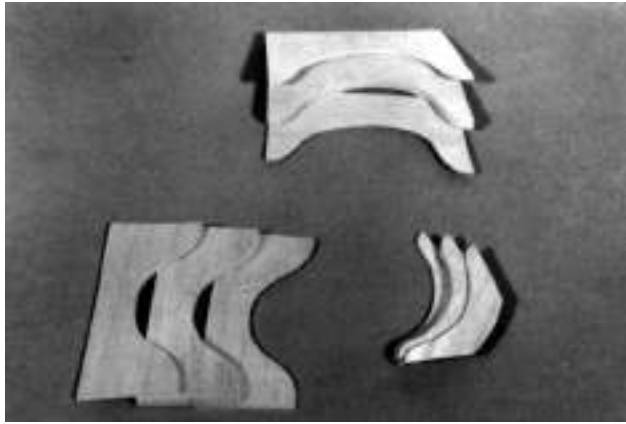

3. Laminate the three fabricated assemblies used in the rudder frame. Note that the 3/16" lamination is the center in all three sub-assemblies.

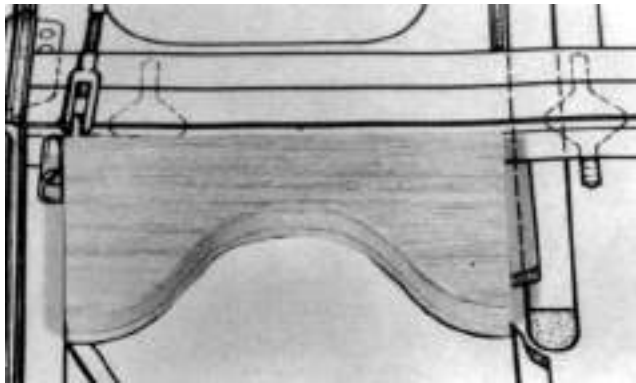

4. Pin the laminated parts over the plan.

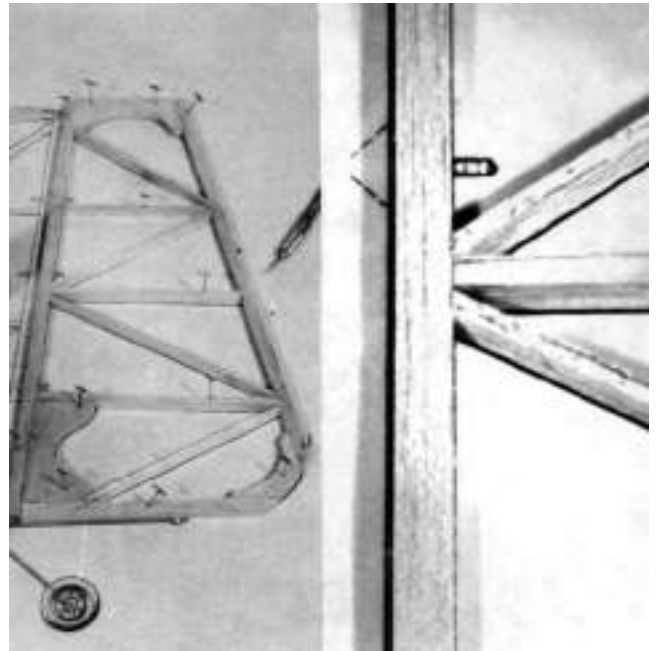

- Glue and pin the 5/16" x 5/16" balsa sticks around the perimeter.

- Trim and glue the 3/16" x 5/16" ribs in place.

- Trim and glue the 1/8" x 5/16" diagonals in place.

ROUNDING & HINGES (12 Steps)

1. Find all the parts that you will need.

THEY INCLUDE:

- (12) FLEX-POINT HINGES
- (1) D.C. PLY ROUNDING TOOL
- (1) D.C. PLY "R" BEVEL TOOL
- (1) D.C. PLY "AE" BEVEL TOOL
- (1) MEDIUM SANDPAPER



5314

PT #3487

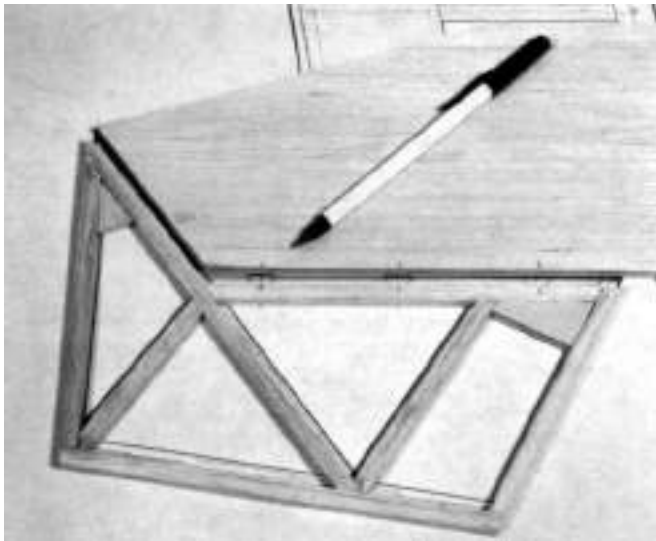

2. Mark the hinge locations onto the rudder and the elevators. Refer to the plan for locations.
- Transfer the hinge locations from the rudder to the fin, and from the elevators to the stab.

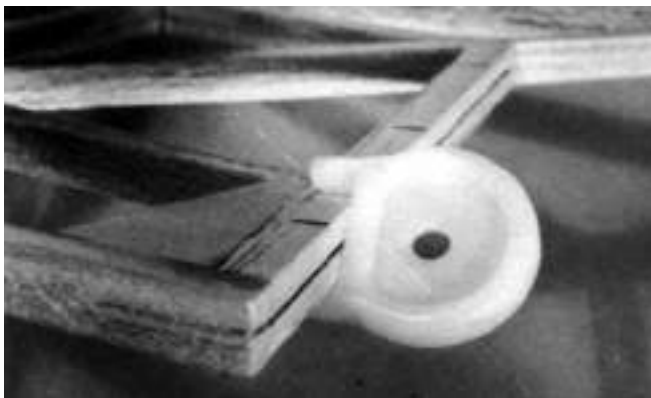

3. Using a C.G. Centerline tool, scribe the centerline onto the rudder post, fin post, the hinge line of the stab and both elevators.



5. Make a slot at each hinge location.

6. Test-fit each hinge to insure a proper fit.

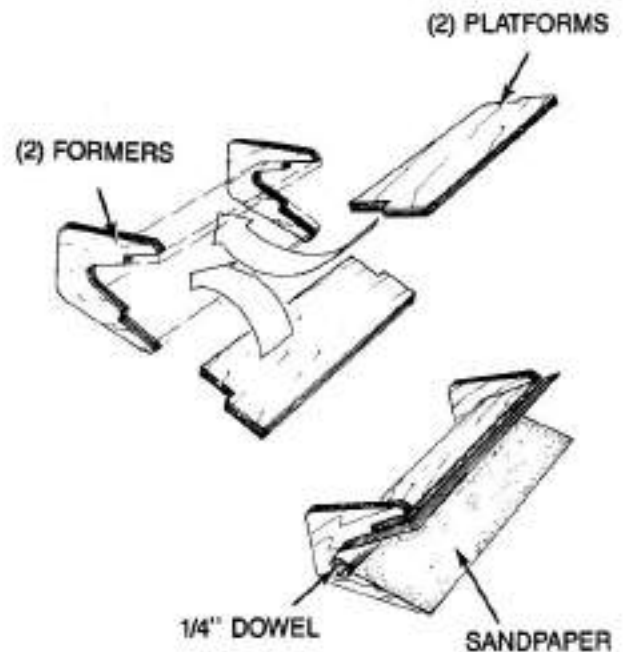

7. Test-fit the rudder/fin and stab/elevators to check the surface alignment.

- Assemble the rounding tool and install a piece of "medium" sandpaper. (SEE DIE SHT. #5314)

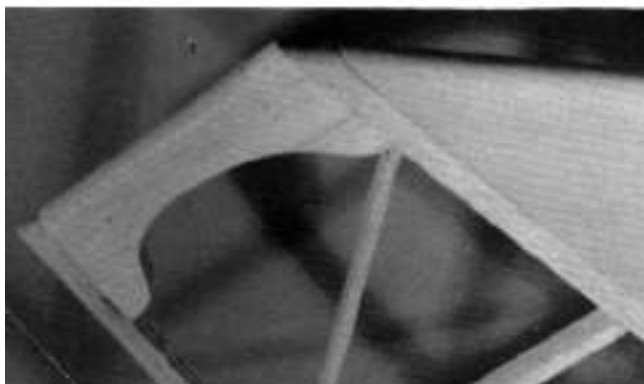
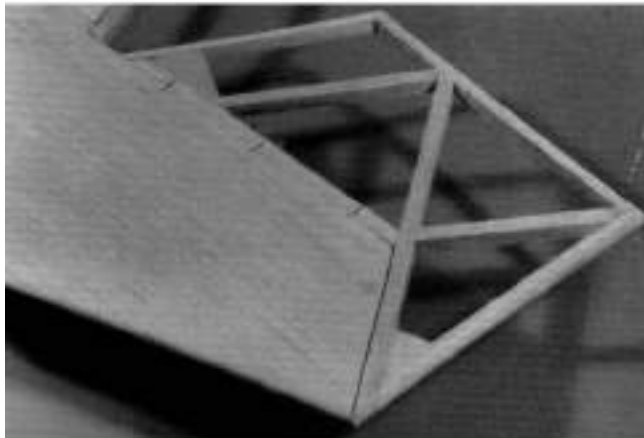
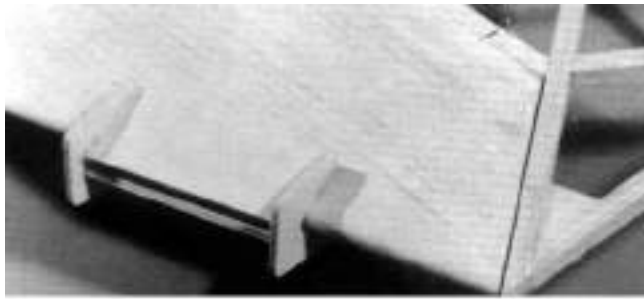

- 8. Use the tool to round the perimeter of the fin/rudder and the elevators/stab.
 - When you are satisfied with the shape, use a piece of "fine" sandpaper to remove the deep scratches.
 - Separate the fin from the rudder and the elevators from the stabilizer.

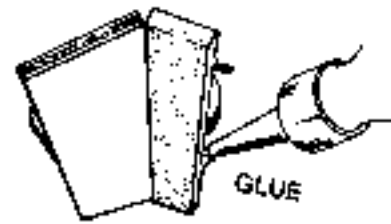
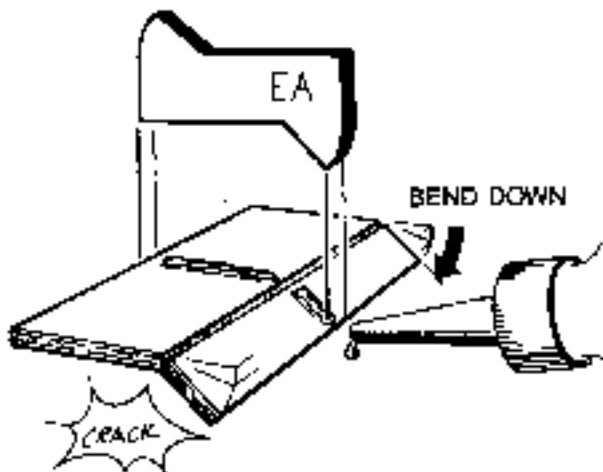

- 9. Assemble the two bevel tools, and install a strip of "medium" sandpaper:



- 10. Using the tool marked "R" bevel the rudder post to a point at the centerline.



- 11. Using the tool marked "AE" bevel the elevators to a point at the centerline. You may want to bevel near the air balances with a knife if you can't use the tool in the corner.

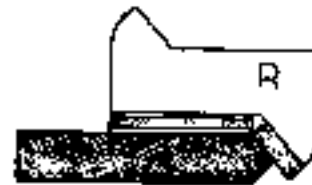

LIKE THIS

- 12. Finish sand all of the parts using a sanding block and "fine" sandpaper. THIS COMPLETES THE TAIL PARTS. PUT THEM AWAY FOR NOW, SINCE YOU WON'T BE NEEDING THEM UNTIL YOU ARE READY TO ATTACH THEM TO THE FUSELAGE.

CONSTRUCTING THE TOP AND BOTTOM WING (50 Steps)

SINCE THE TOP AND BOTTOM WING ARE BASICALLY THE SAME, EXCEPT FOR A FEW INTERNAL DIFFERENCES, YOU WILL BUILD THEM BOTH OVER THE SAME PLAN. THE INSTRUCTIONS WILL LEAD YOU THROUGH THE ASSEMBLY SEQUENCE, SENDING YOU BACK AND REPEATING STEPS, SKIPPING STEPS AND JUMPING AHEAD. CAREFULLY READ EACH STEP BEFORE YOU PROCEED TO DO THE INSTRUCTION. THE RESULTS WILL BE A COMPLETED TOP AND BOTTOM WING.

1. Find all the parts that you will need to build both the top and bottom wings.

THEY INCLUDE:

- (8) 1/8" x 1/4" x 27-3/8" BASSWOOD
- (4) SHAPED L.E. Balsa
- (4) NOTCHED T.E. Balsa
- (4) WING RIBS Balsa (DIE SHT. #5312)
- (4) WING RIBS Balsa (DIE SHT. #5313)
- (2) WING RIBS & JOINER PLY (DIE SHT. #5314)
- (4) WING CENTER SHEETING Balsa (DIE SHT. #5315)
- (24) 1/16" x 1" x 2-1/2" SHEAR-WEBS ... Balsa
- (2) WING JOINER PLY (DIE SHT. #5316)
- (4) INBOARD T.E. Balsa
- (10) 1/16" x 3/8" x 24" CAPSTRIPS Balsa
- (4) AILERONS Balsa
- (8) 1/16" x 2-3/4" x 28" L.E. SHT. Balsa
- (8) 1/16" x 1" x 28" T.E. SHT. Balsa
- (2) WING STRUTS PLY (DIE SHT. #5309)
- (2) 3/4" x 20" NYLON FABRIC
- (1) BOTTOM WING BLOCK BASS
- (2) .063" x 18-1/2" AILERON WIRE
- (2) .072" x 10-1/2" THREADED ROD (BOTH ENDS)
- (2) AILERON BELCRANKS
- (2) AILERON BUSHINGS
- (2) 2-56 NUT
- (2) 2-56 x 1/2" MACHINE SCREW
- (2) #2 WASHER
- (4) NYLON SNAP-NUT
- (2) THREADED RODS (BELCRANK TO AILERON)
- (3) 1/16" I.D. x 1" BRASS TUBE
- (1) AILERON COUPLER BLOCK
- (1) 2-56 x 3/4" MACHINE SCREW
- (1) 2-56 x 1/8" MACHINE SCREW
- (1) SNAP LINK
- (2) BRASS EYELETS (TOP WING ONLY)
- (12) FLEX POINT HINGES
- (1) 1/8" x 5-1/8" NYLON TUBE



AILERON STOCK



1/8" x 1/4" BASS



SHAPED L.E. Balsa



NOTCHED T.E. Balsa



1/16" x 3/8" Balsa



5312

PT #3278



5313

PT #3279

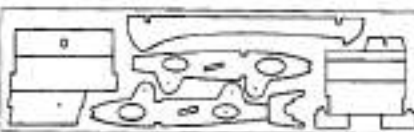

5314

PT #3467



5315

PT #3280

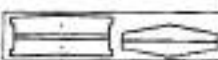

5316

PT #3468

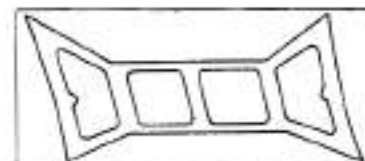

5309

PT #3465

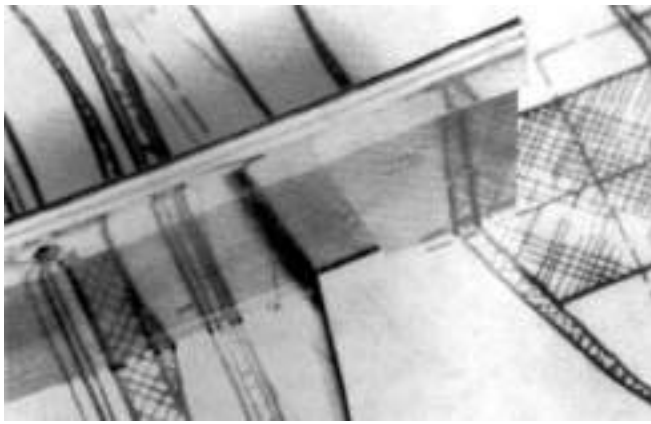

2. Lay the wing over your building board.
- Cover the plan with waxed paper.
- Lay a 1/8" x 1/4" x 27-3/8" BASSWOOD SPAR over the plan and cut the angle at the wing centerline. Use this spar as a pattern to cut the remaining 7 spars.

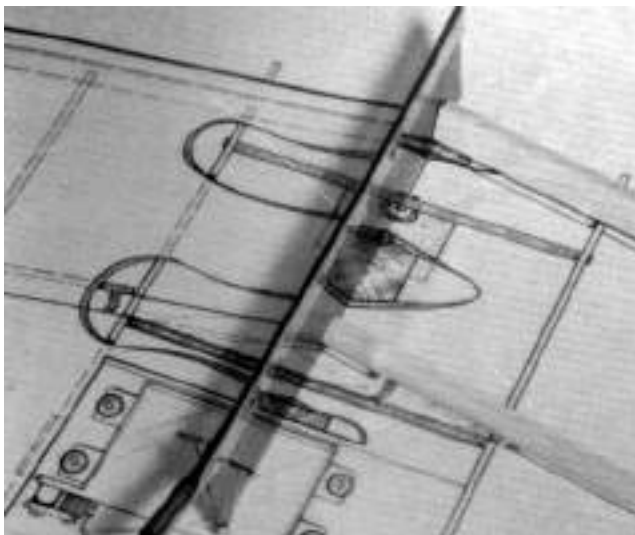

- Lay a shaped L.E. over the plan and cut the angle at the centerline. Do this to all 4 leading edges.

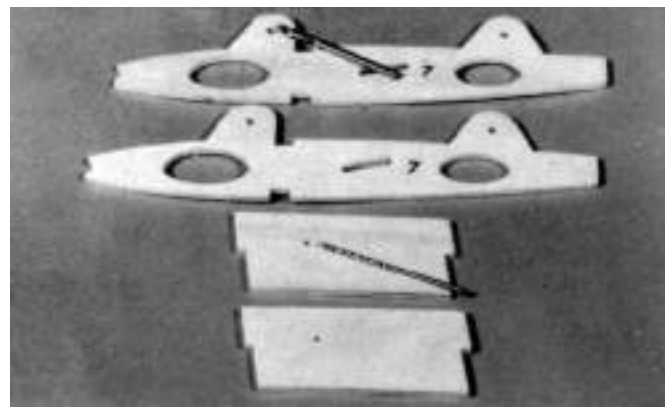
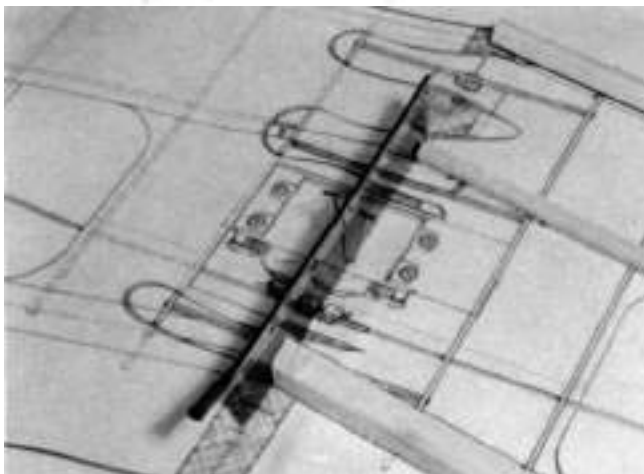

3. Drill a 1/16" hole at the center point mark on both alleron belcrank mounting plates and all 4 plywood wing ribs.

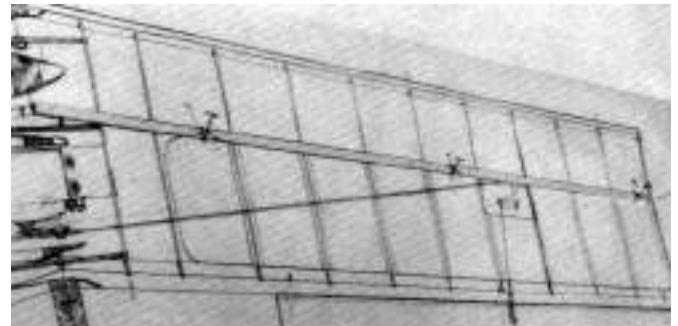

4. Scissors-pin a spar over the plan.

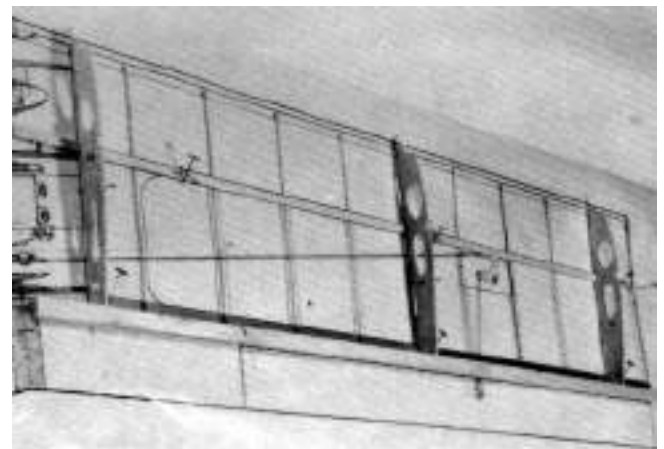

5. Pin ribs #'s 2, 5 and 5 over the plan, but do not glue.
- Place the notched T.E. on the support tabs, with the cut end at the centerline. Press the ribs into the notches and glue.

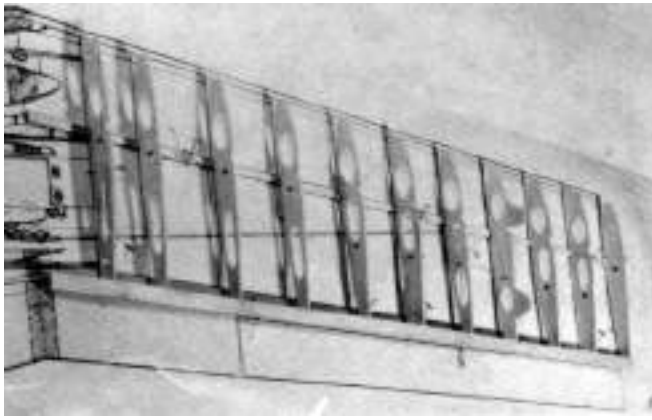

Place the remaining ribs into the notched T.E. and onto the spar, but do not glue.

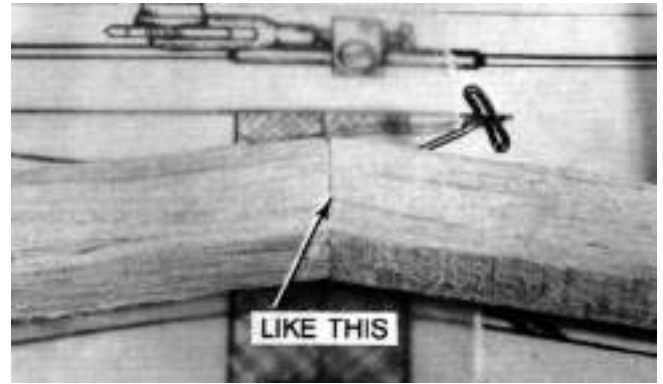

9. If this is your 1st or 3rd time through the process, go back to step #4 and repeat, building the other wing half onto this half. Make sure the joints fit tightly.

If this is your 2nd or 4th time through the process, go on to step #10.



6. (BOTTOM WING ONLY) Install the alleron belcrank platform between ribs 6 and 7.

Note the position of the hole, see plan for clarification.



7. Position the shaped L.E. onto the support tabs. Make sure that the beveled end is in line with the wing centerline.

8. Check the wing alignment with the plan below. Place a drop of JET glue at each joint along the spar, L.E., T.E. and the belcrank platform.

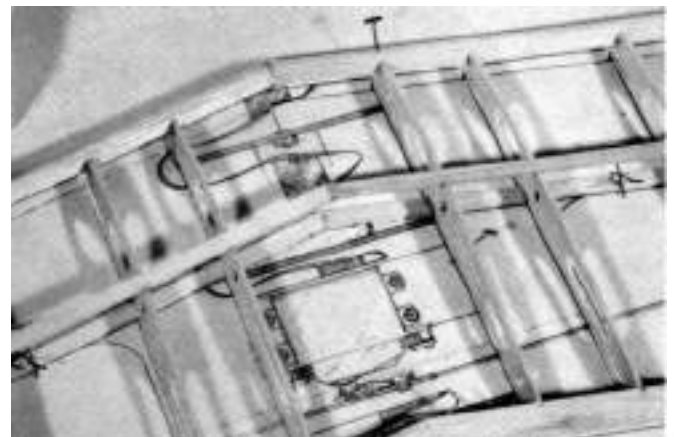

10. Install the top spar into the notches on each wing rib. Make sure that the spar center joint is directly over the bottom spar joint before gluing.

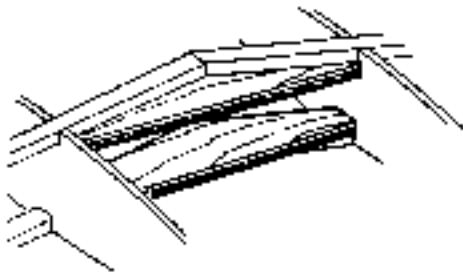

11. Glue a D.C. 1/8" ply wing joiner to the top of the bottom spar joint and the bottom of the top spar joint.
 Note: Lightly sand the gluing areas before gluing.



12. Glue a D.C. ply joiner web to the back of the two spar joiners. Make sure that the center plug is punched out.

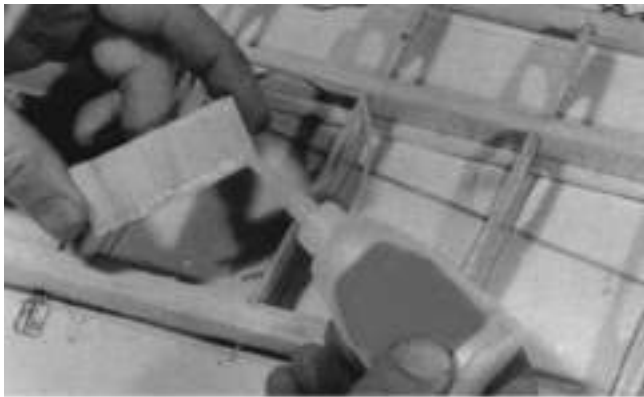

13. Glue 1/16" x 1" x 2-1/2" balsa shear webs between the ribs, on the front side of the spars. Trim-to-fit between ribs 2 and 3.

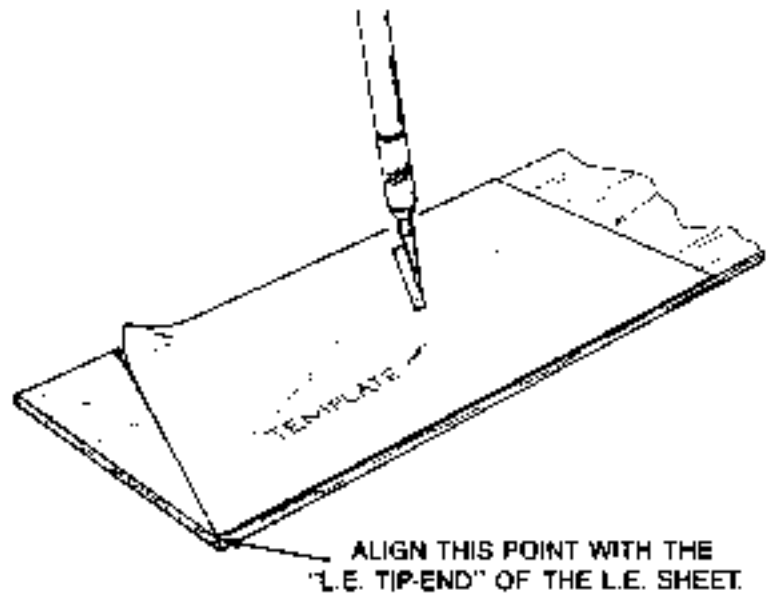

14. Using the template provided, cut the slot in two 1/16" x 2-3/4" x 28" balsa L.E. sheets.

TEMPLATE ON PAGE 47

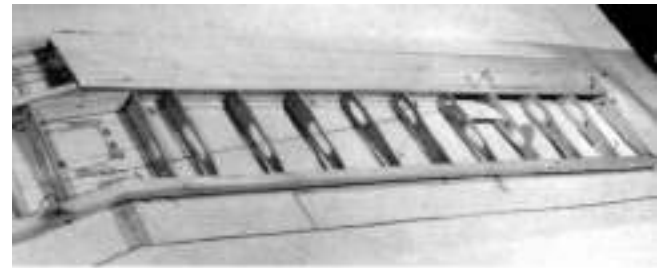

15. Relocate the pins that may interfere with the installation of the L.E. sheets. The wing must remain firmly fixed to the board while installing the sheeting.
 With the edge of the sheeting resting in the shaped L.E. shoulder, roll back and fit the slot around the tab of rib 7.



Mark the centerline of the wing onto the sheeting, and cut the angle.



Run a bead of glue on the L.E., ribs and spar. Quickly roll the sheeting back into position, pinning and taping as needed.



16. Tape the sheeting to the L.E. the entire length.

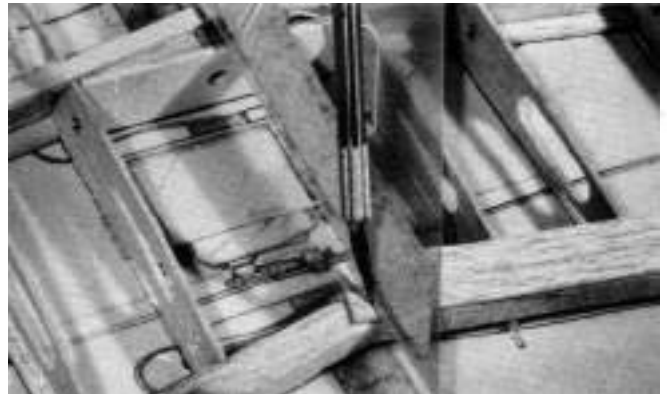

17. Cut the angle at the wing centerline.



Roll the sheeting forward using the tape as a hinge.



Glue the 1/16" x 1" x 28" balsa sheet to the notched T.E. and the short segment of the ribs.



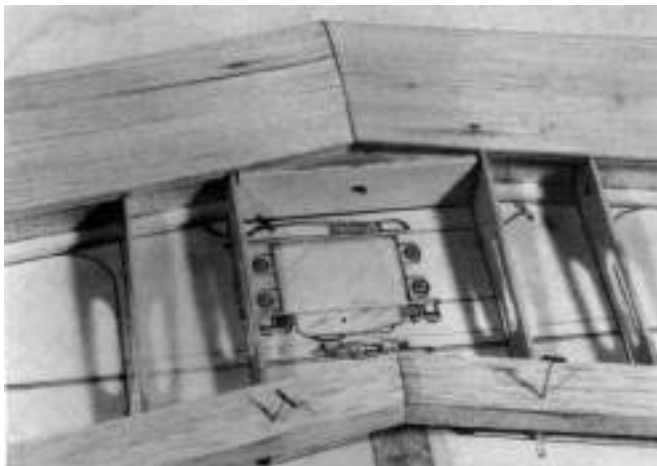

18. Go back to step 15 and repeat the sequence to sheet the other wing half fitting the seam as shown.

IF THIS IS YOUR FIRST TIME THROUGH THE BUILDING SEQUENCE YOU ARE BUILDING THE BOTTOM WING. GO ON TO STEP #19, AND PROCEED TO INSTALL THE AILERON LINKAGE.

IF THIS IS THE SECOND TIME THROUGH YOU SHOULD ALREADY HAVE A BOTTOM WING. YOU ARE NOW IN THE MIDDLE OF CONSTRUCTING A TOP WING. SKIP DOWN TO STEP #33 AND CONTINUE.

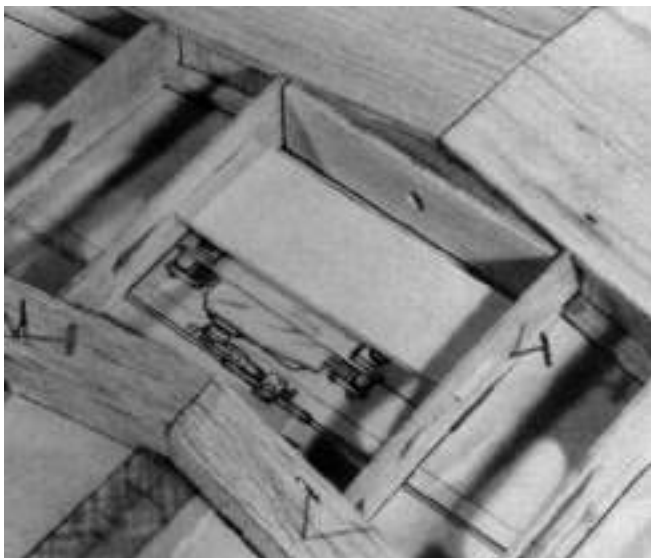

19. Glue the D.C. ply aileron servo mount in place. Note that the tabs are to the T.E. side.

Note: For better performance go to page 44 on installing servos (2) in the bottom wing.



20. Bend a 1/4" x 90 degree angle at one end of the .062" diameter x 18-1/2" wire pushrod.
- Install a aileron belcrank onto the bend and secure with a snap-nut. See plan for correct orientation. Place a drop of JET glue on the snap-nut.

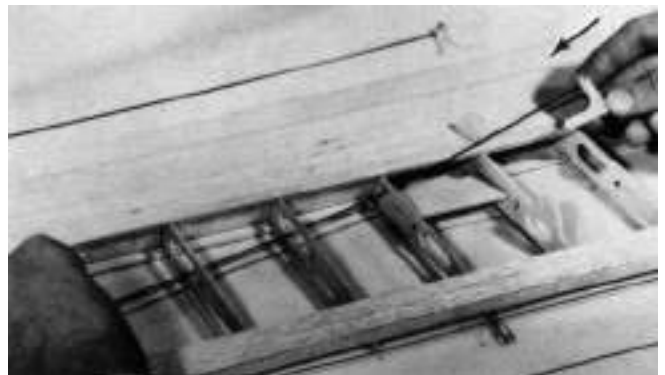

- Slide the pushrod assembly through the openings in the wing ribs from the tip-end toward the center.

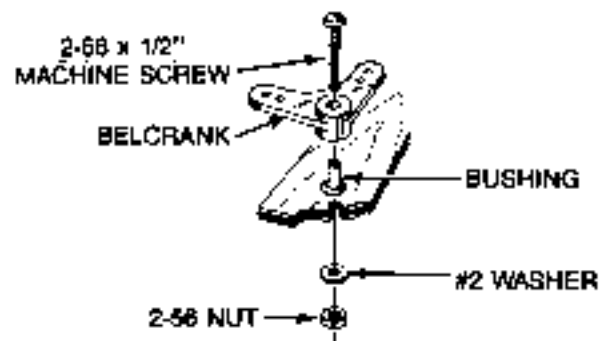

- Install the hardware to mount the belcrank to the platform.

21. Repeat step 20 for the other wing half.

22. Assemble the aileron coupler.

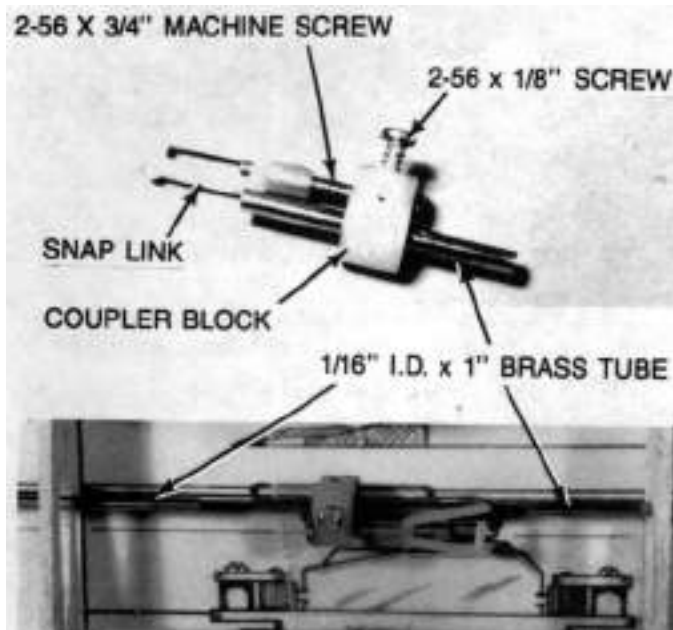

23. Slide a 1/16" I.D. x 1" brass tube onto the left aileron pushrod and one tube onto the right aileron pushrod.
- Slide the aileron coupler assembly onto both pushrods.

IMPORTANT

- Use a pin to "fix" the belcranks in the neutral position, shown on the plan.
- Solder the coupler tube to each pushrod. The other tubes will be positioned after the servo is mounted.

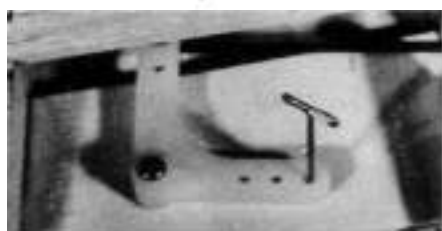

24. Make two pushrods to fit the template shown here.

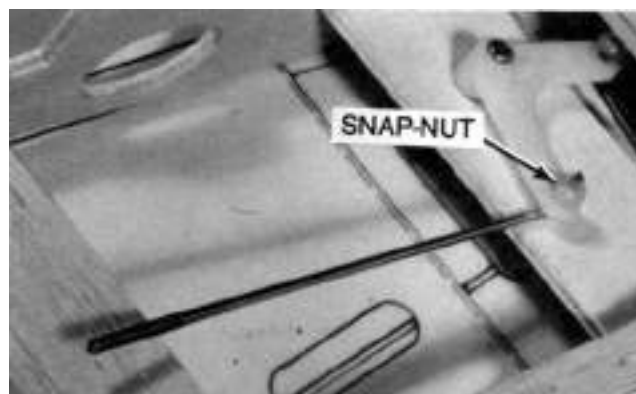

25. Install the threaded pushrods onto the belcranks, and secure with a snap-nut. Place a drop of JET glue on the snap-nut.



26. Slip the pushrod exit sheet over the pushrod and glue to both wing halves.



27. Cut and glue the 1/16" x 3/8" balsa capstrips to the ribs.

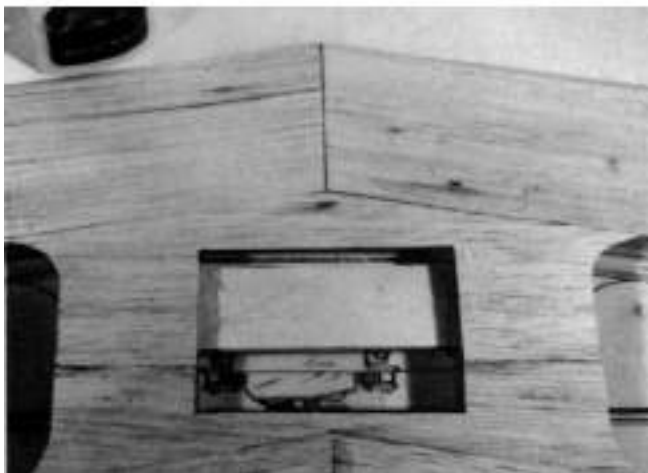
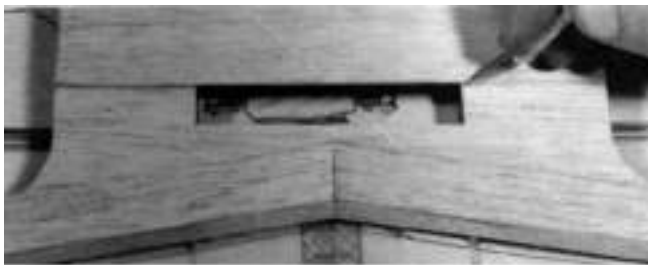

28. Cut out the opening for the aileron servo as you install the center sheeting.

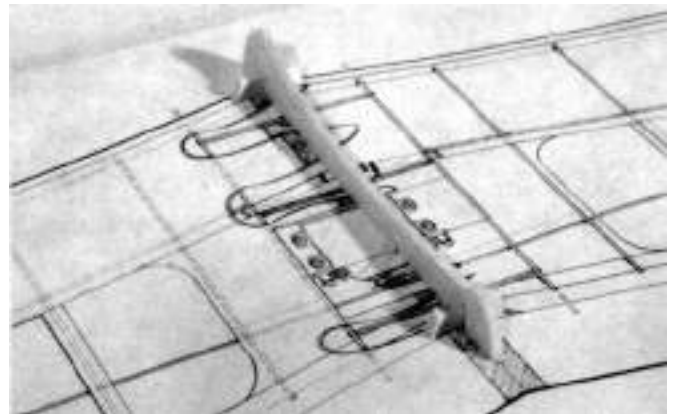

29. Unpin the wing from the building board.
 Assemble the D.C. ply center support and position it over the centerline of the plan



Flip the wing over and pin to the board over the plan and the center support.
 Slide the front and rear D.C. plywood plates into the slots in ribs #2 and glue.

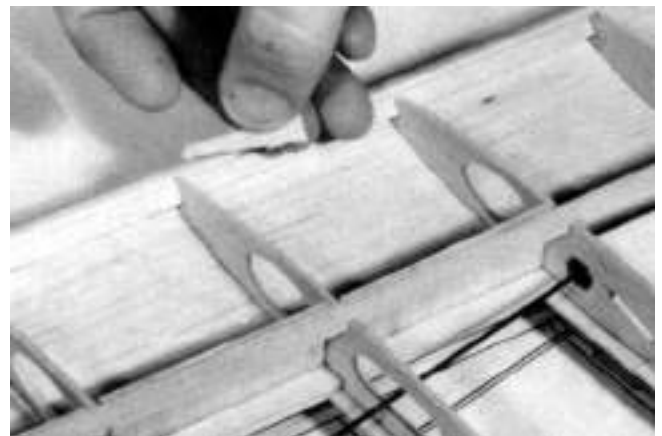

30. Break off the support tabs on the wing ribs.

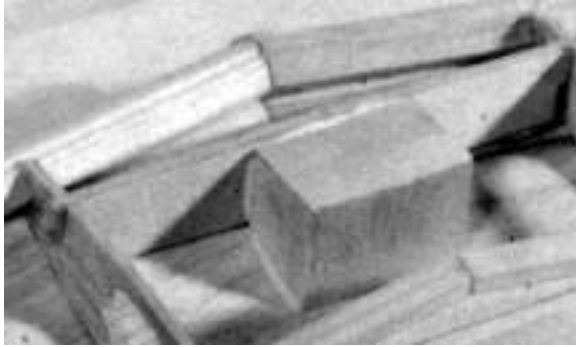

31. EPOXY the pre-cut bass filler block to the ply front plate and 1/16" balsa L.E. sheeting.



32. Install the L.E. sheeting. Be sure to use the sheets WITHOUT the slots. Refer back to steps #15-17 for help. EPOXY the top sheeting to the balsa filler block.

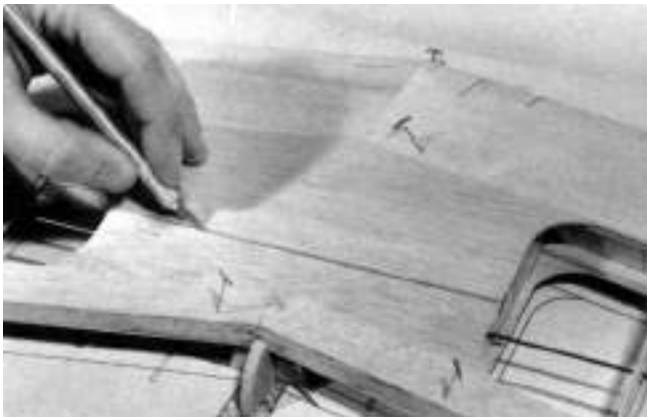

- Install the T.E. sheeting. Refer to step #17 for help.
- Install the D.C. center sheeting. Don't cut out for the servo on this side.



- Capstrip all the ribs using 1/16" x 3/8" balsa.

THAT COMPLETES THE BOTTOM WING FOR NOW. YOU WILL NEED TO PUT THE FINISHING TOUCHES ON BOTH WINGS WHEN THEY ARE BOTH TO THIS POINT. NOW GO BACK TO STEP #4, SKIPPING STEP #6, AND START CONSTRUCTING THE BOTTOM WING.

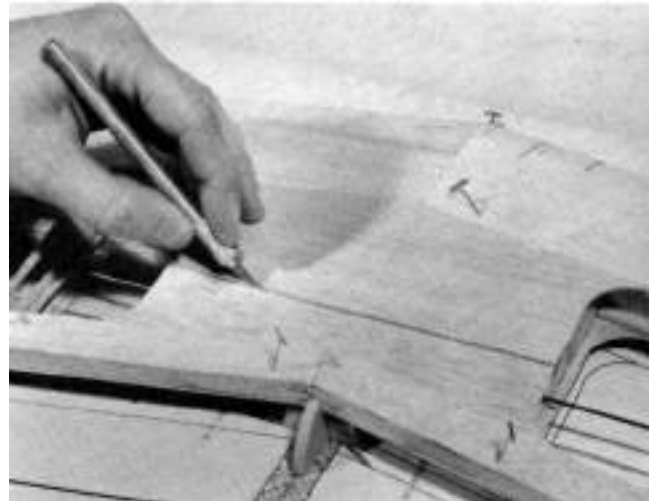

33. Sheet the center section.

- Capstrip the ribs and install the sheeting at rib 6-7 even though there is no aileron linkage in the top wing.



34. Unpin the wing from the building board and place the center support over the centerline of the plan.
- Flip the wing over and pin it back down over the plan and center support.

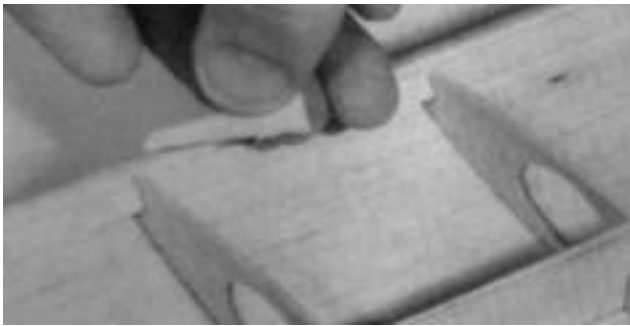

Break off the support tabs on the wing ribs.

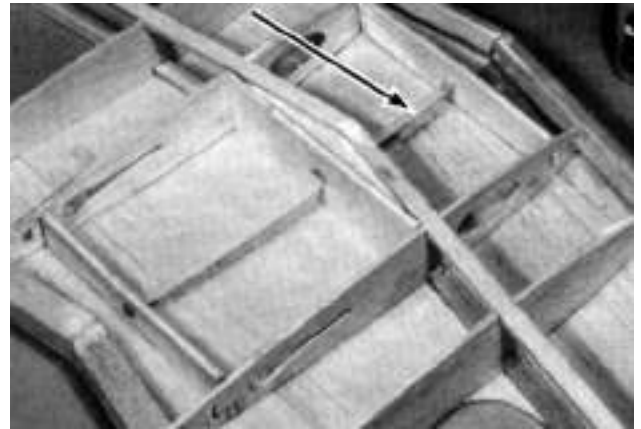

Slide the 1/8" nylon tube through the hole in the ply joiner and fit onto each eyelet. Trim the tube if necessary.

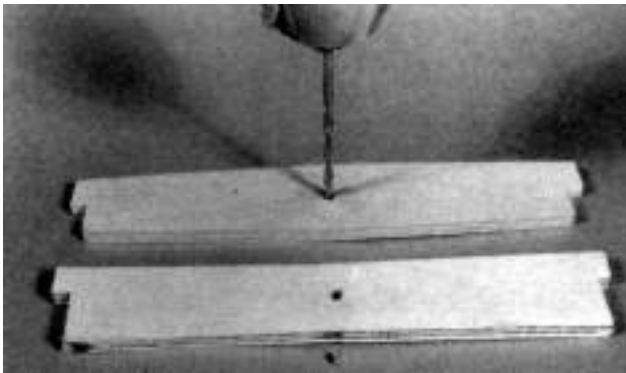

35. Drill a 3/32" diameter hole at the punch marks on the front and rear D.C. plywood plates.

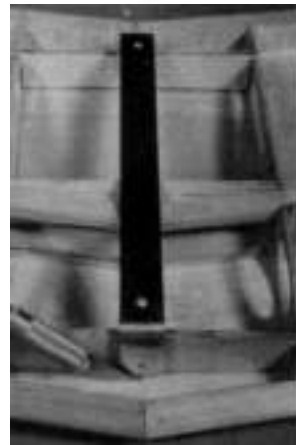

37. Using the formed aluminum top bracket as a gauge, cut the front and rear clearance slots.

Glue in the brass eyelets.



36. Glue the ply plate assemblies into the rib slots, with the L.E. plate eyelet flange facing the L.E. and the T.E. plate eyelet flange facing the T.E.

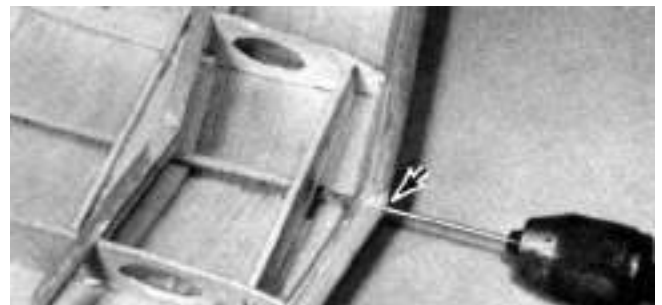

38. Drill a 3/32" hole at the leading edge joint.



Grind a chamfer on the end of the wing hold down wire.

Test fit the wire.

39. Install the remaining L.E. sheets. Refer to step #'s 15-17 for help.

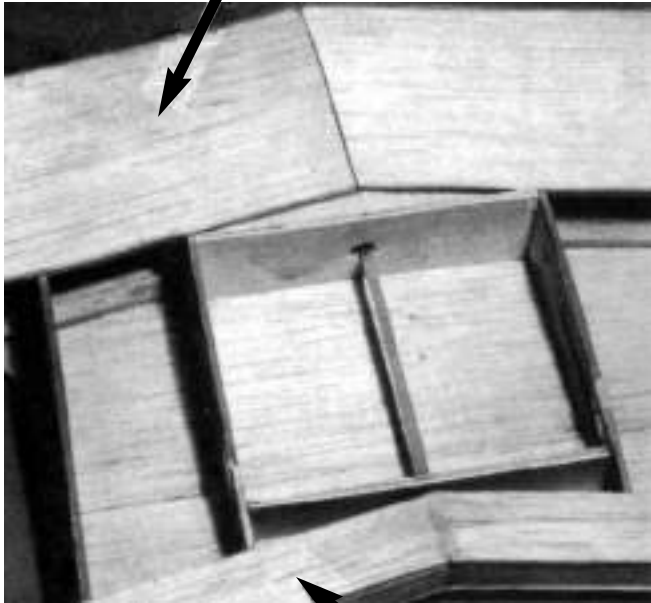

40. Install the remaining T.E. sheeting. Refer to step #17 for help.

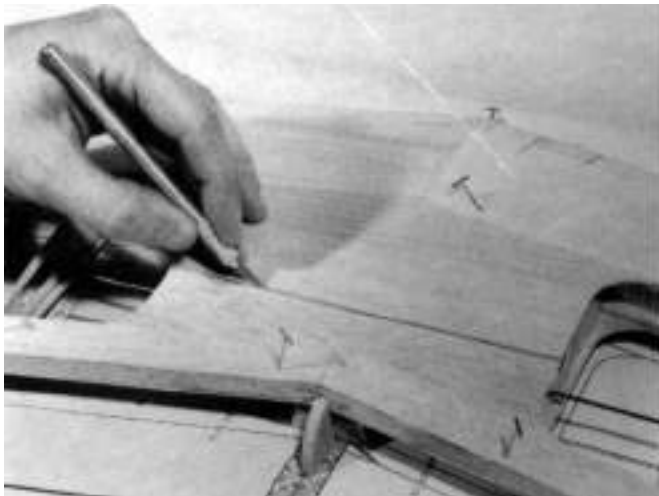

41. Install the 1/16" D.C. center sheeting.
 Install 1/16" x 3/8" balsa capstrips.

REMOVE THE WING FROM THE BUILDING BOARD. YOU NOW HAVE A TOP AND BOTTOM WING. THE FOLLOWING STEPS APPLY TO BOTH WINGS FOR COMPLETION.

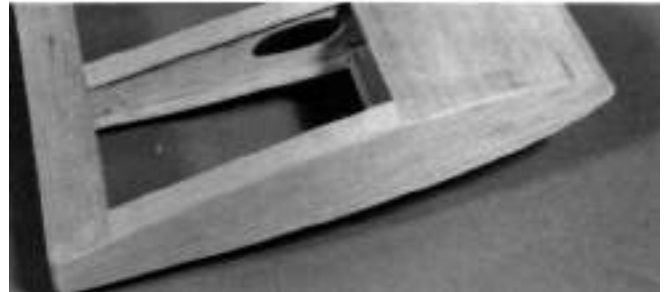

42. Sand flat the end ribs and glue the balsa end cap to all four wing tips.

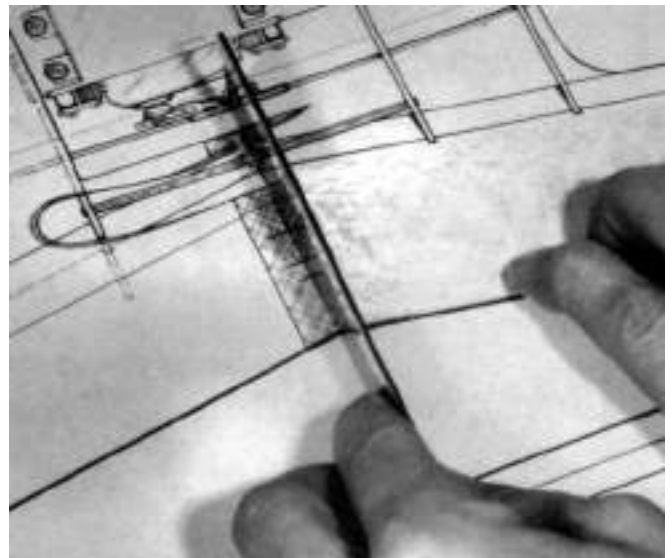

43. Refering to the plan, cut the inboard T.E. parts to length and the correct angle.

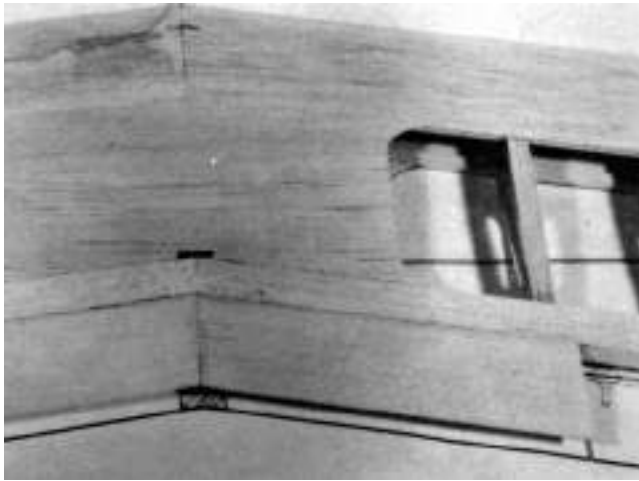

□ Glue the T.E. parts to the wings.



44. □ Completely wrap the center of the wings with 3/4" nylon tape, using JET glue as you go.

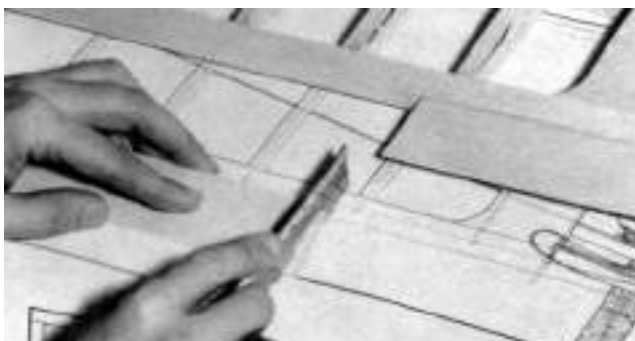

45. □ Cut the aileron angle using the plan as a reference.

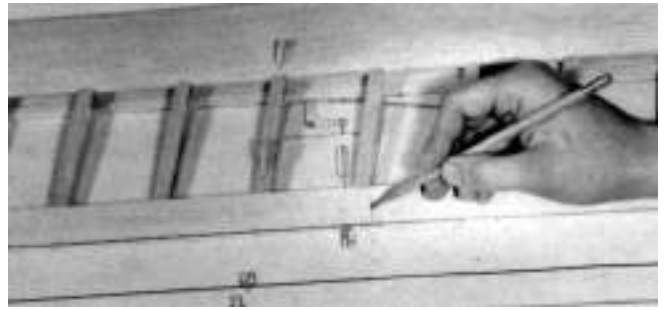

□ Mark the hinge locations from the plan onto the wing.

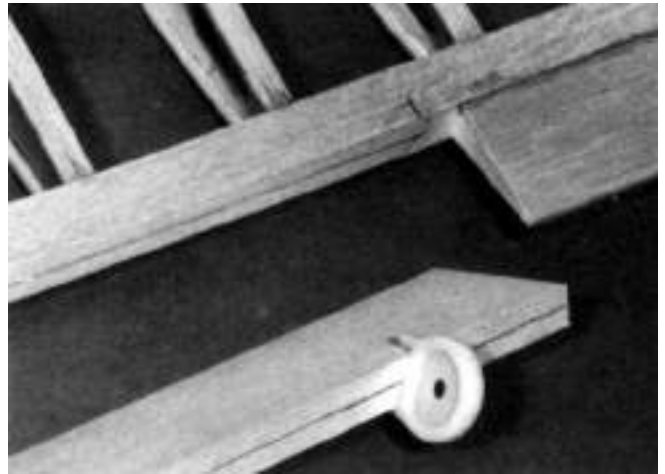

46. □ Use a C.G. centerline tool and scribe a hinge centerline into all of the ailerons, and both wings.

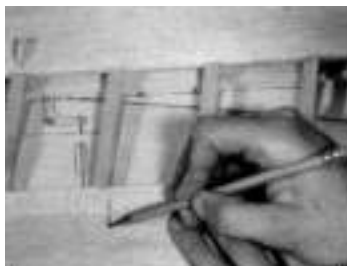

47. □ Transfer the hinge marks from the wing onto the aileron.

LEAVE A 1/16" GAP BETWEEN THE INBOARD T.E. AND THE AILERON.

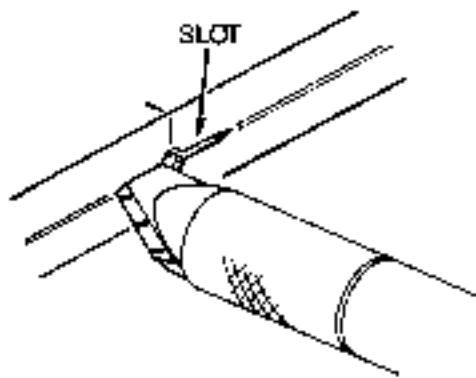

- Slot the hole along the centerline for hinge flange fit-up.



48. Hinge the ailerons to the wings and sand the ends flush with the wing tips.

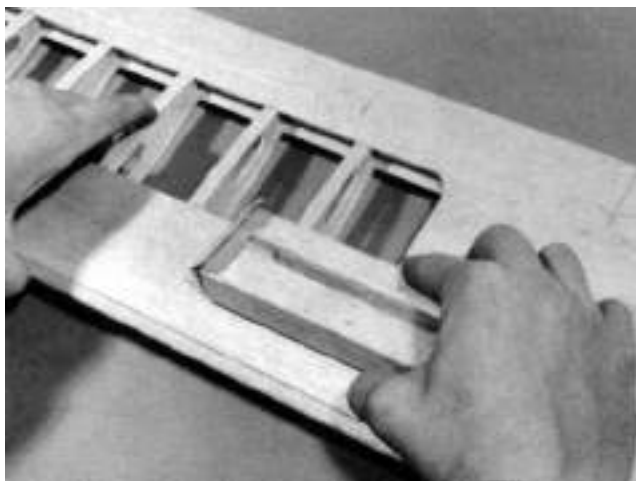

- Sand both wings at this time.

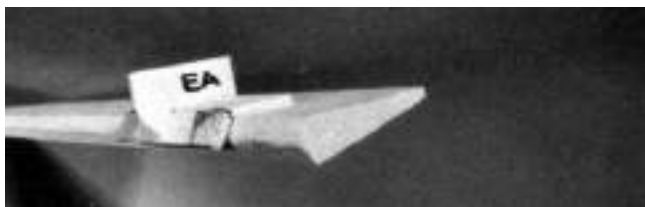

49. Mark the ailerons to the corresponding wing halves, and disassemble.
- Bevel the ailerons to the center scribe line, using the bevel tool marked "AE."



Note that you will permanently assemble the ailerons to the wings after covering, and then install the control horns.



50. Connect the aileron servo to the pushrod. Locate the servo so that the bellcranks are in the neutral position.

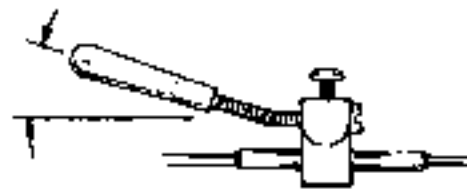

Note: Bend the 2-56 bolt "up" to achieve the proper servo/pushrod alignment.



- Center the brass tubes, on the aileron pushrods, in each wing half at rib#3.

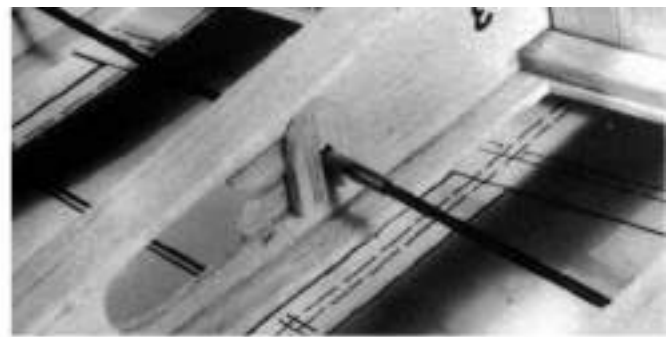

Glue the "horseshoe"-like balsa part to rib #3, locking the brass bushing in the wing.

THIS COMPLETES THE TOP AND BOTTOM WING. NOW LET'S MOVE ON TO THE FUSELAGE.

CONSTRUCTING THE FUSELAGE (31 Steps)

1. Find all the parts that you will need to build the FUSELAGE.

THEY INCLUDE:

- (2) SIDE PLY (DIE SHT. #5301)
- (1) TOP PLY (DIE SHT. #5302)
- (1) BOTTOM PLY (DIE SHT. #5303)
- (1) FORMERS PLY (DIE SHT. #5304)
- (1) DOUBLERS &
FORMERS PLY (DIE SHT. #5305)
- (1) FIREWALL PLY (DIE SHT. #5306)
- (1) FRONT/TOP SHT. 5/64" Balsa
(DIE SHT. #5307)
- (1) FRONT-SIDE SHT. 5/64" Balsa
(DIE SHT. #5308)
- (1) TURTLEDECK 1/32" PLY
(DIE SHT. #5311)
- (1) TRIPLERS, FORMER "EE" &
TANK TRAY PLY (DIE SHT. #5317)
- (2) FORMED CABANES ALUMINUM
- (2) 1/8" x 1/2" x 21" Balsa

- (2) 1/8" x 1/8" x 18" Balsa
- (2) 3/16" x 3/16" x 18" Balsa
- (1) 1/8" x 3/16" x 18" Balsa
- (1) 1/2" TRIANGLE x 8" Balsa
- (1) WING MOUNTING-FRONT BASS
- (1) WING MOUNTING-REAR BASS
- (1) LANDING GEAR BLOCK PLY

HARDWARE:

- (4) 4-40 x 3/8" SOCKET HEAD BOLTS
- (4) 4-40 SELF-LOCK NUTS
- (4) #4 WASHERS
- (6) 6-32 BLIND NUTS
- (5) 6-32 x 1" SOCKET HEAD BOLTS
- (1) 6-32 x 1-1/4" SOCKET HEAD BOLT
- (10) #6 WASHERS
- (2) #6 x 3/4" WASHERS

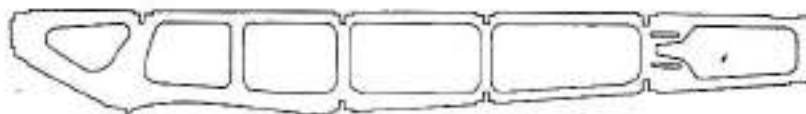

5301

PT #3459

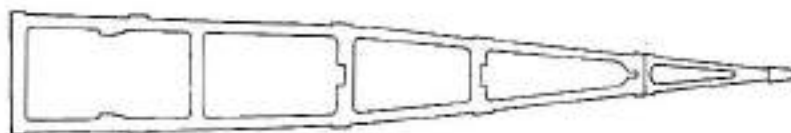

5302

PT #3460

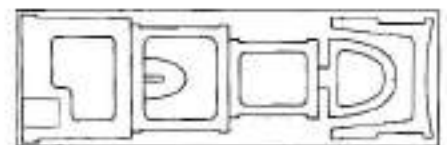

5304

PT #3462



5308

PT #3276

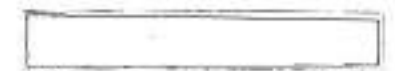

5307

PT #3275

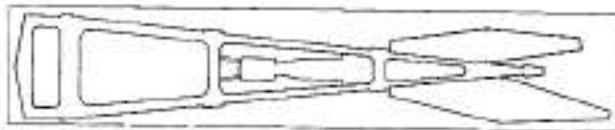

5303

PT #3461

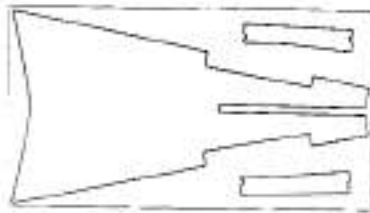

5311

PT #3466

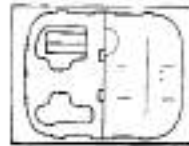

5306

PT #3464



5305

PT #3463





5317

PT #3469

 1/8" x 1/2"
BALSA

 1/8" x 1/8"
BALSA

 3/16" x 3/16"
BALSA

 1/8" x 3/16"
BALSA

 1/2" x 8" TRI
BALSA

2. Carefully remove the parts from the die sheets.
- Lightly sand the rough edges of each part.

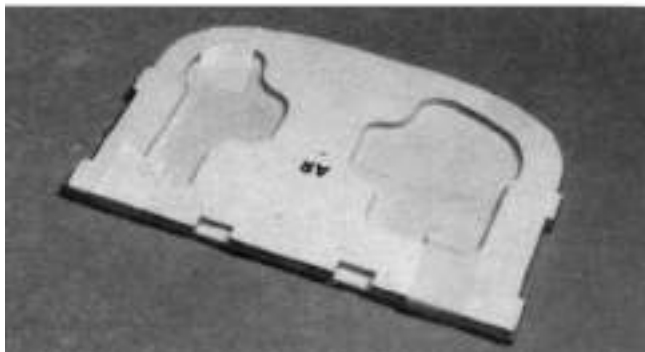
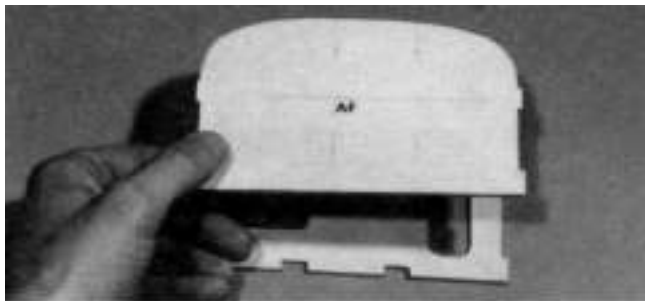

3. Glue the "AF" to "AR" to form the FIREWALL. Make sure that all edges match and that the assembly is perfectly flat. Tape together until dry.

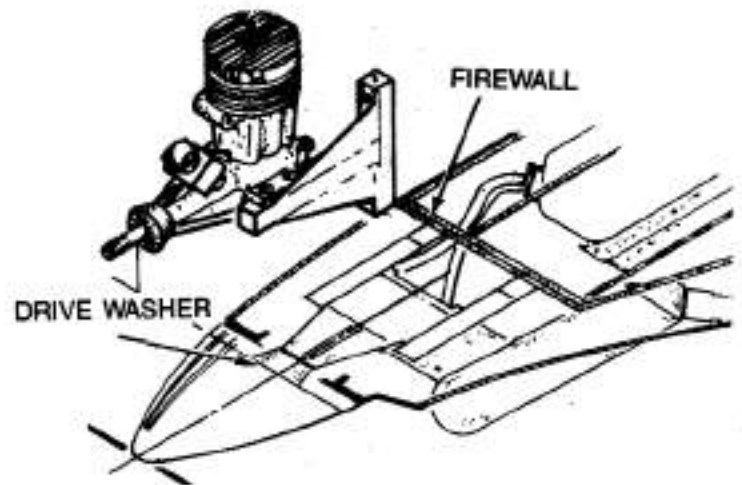

4. Position the "DRIVE WASHER," of the engine that you will be using, over the drive washer on the plan.
- Place the C.G. MOTOR MOUNT against the firewall over the plan.

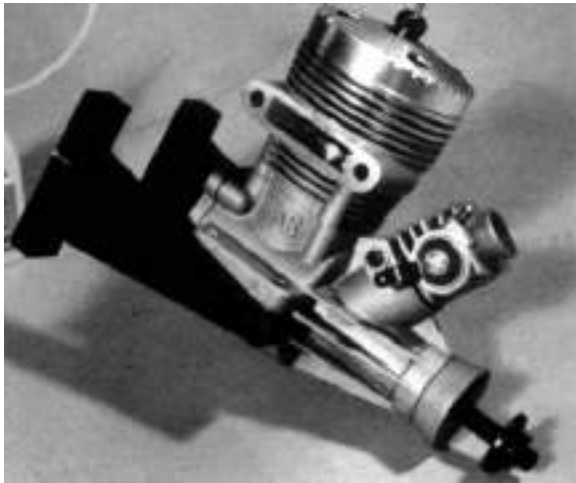

Tack glue the engine to the mounts.

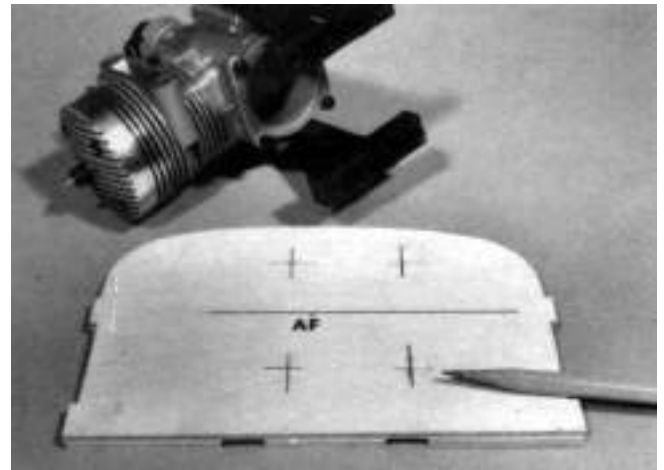

With the holes on the vertical scribe marks on the firewall, mark all 4 mounting bracket locations

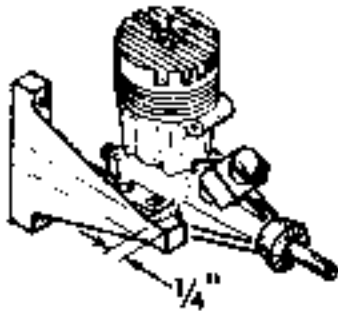

Note: Make sure that this dimension is at least $\frac{1}{4}$ ". If not, use the $\frac{1}{8}$ " ply spacer plates between the firewall and the motor mounts.

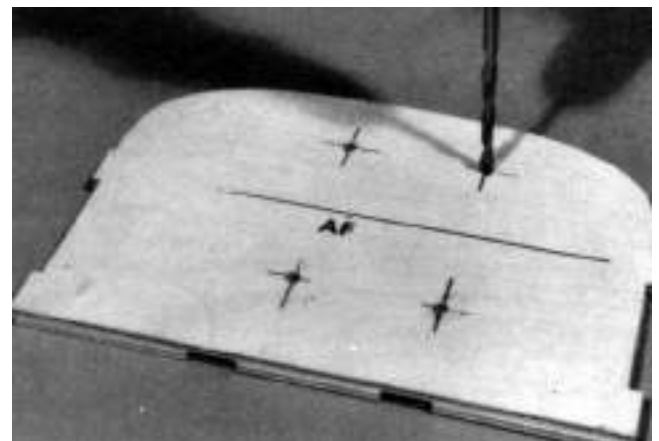

Drill a $\frac{5}{32}$ " hole at each location.

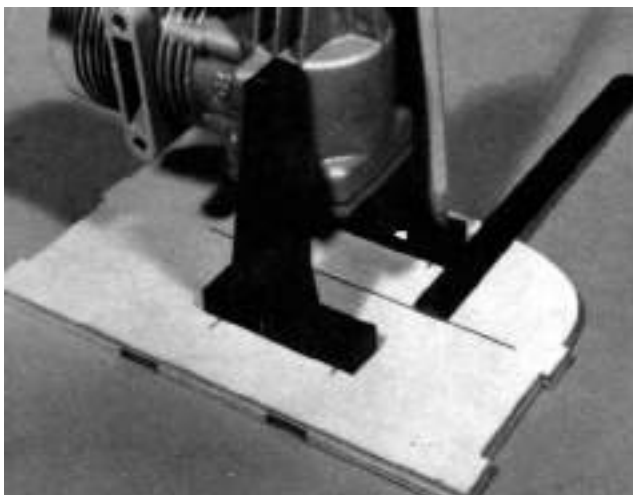

5. Place the motor assembly over the "AF" side of the firewall.

Measure $\frac{1}{2}$ of the total distance between the mounts, from the scribe mark, on the firewall, to one of the mounts.



Turn the firewall over and insert the four 6-32 blind nuts. Seat them with a soft hammer blow.

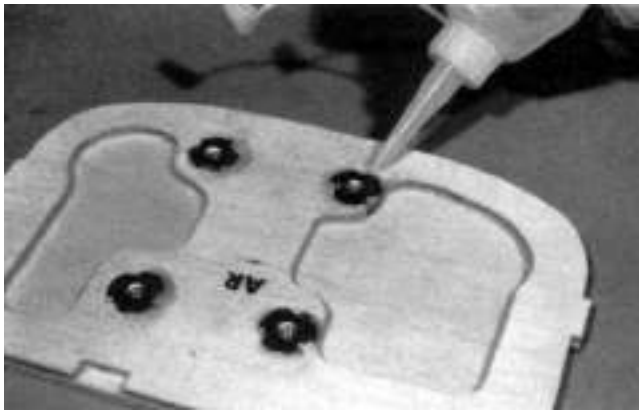

- Coat the edges of the nut with JET glue. Be careful not to get glue in the threads. Put the assembly aside for now.

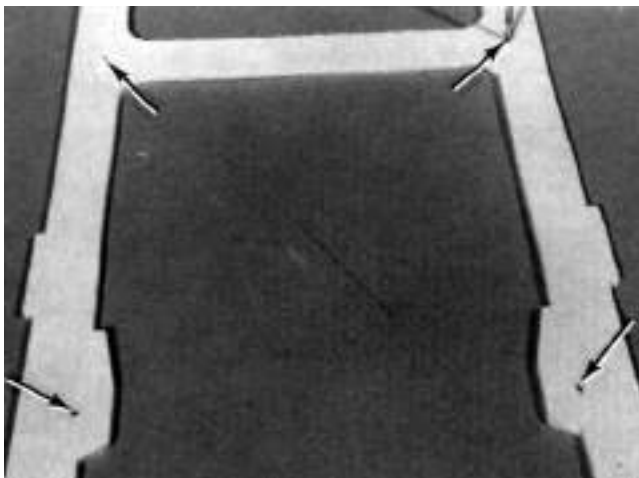

- 6. Drill a 3/32" hole, at the four center marks, in the fuselage top piece. Put the drilled top aside for now.

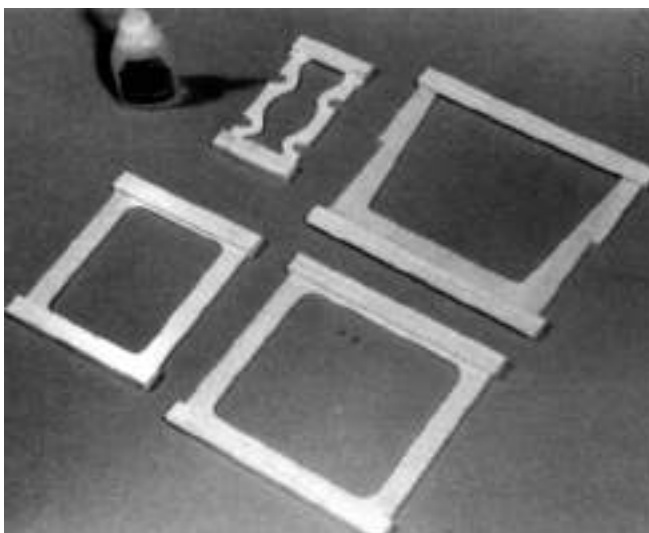

- 7. Locate, glue and trim the 1/8" x 1/2" balsa doublers to the four formers: "B," "C," "D" and "E."

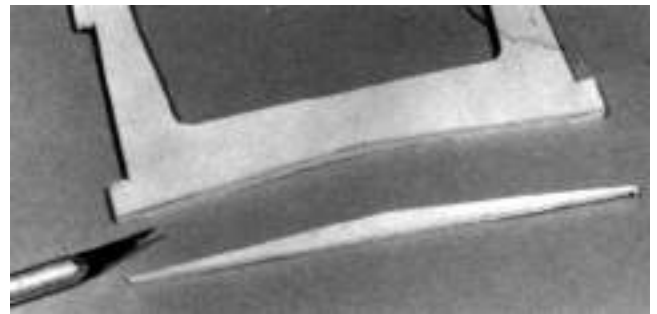

- Trim the bottom of former "B".

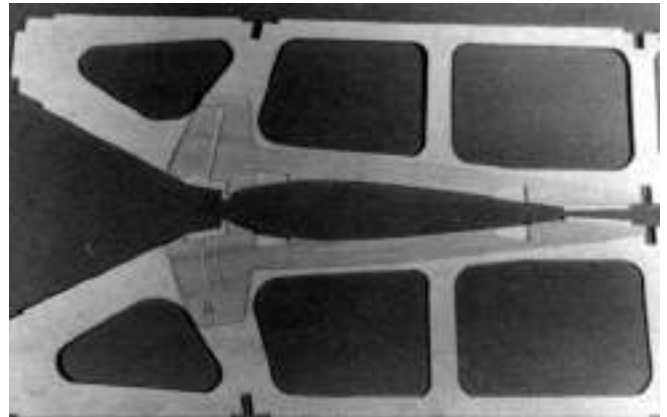

- 8. Glue the wing-saddle doublers to the inside of the fuselage sides. Reference the "C" former slot for the correct alignment.

IMPORTANT: MAKE SURE THAT YOU BUILD A LEFT AND RIGHT FUSELAGE SIDE. LAY THE SIDES "MIRROR IMAGE" TO AVOID BUILDING TWO OF THE SAME SIDES.

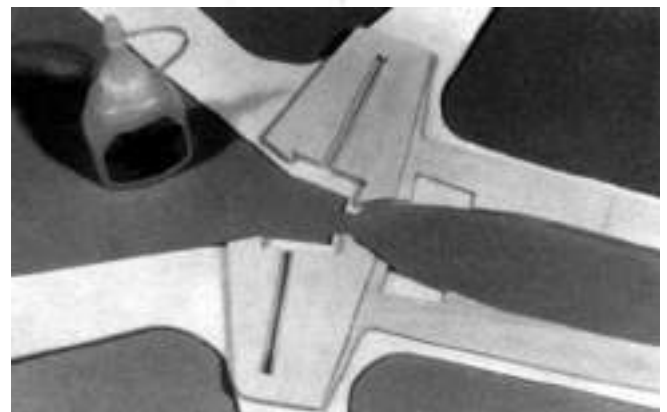

- 9. Glue the landing gear triplers onto the wing saddle doublers. Make sure that the landing gear wire slots are in line.

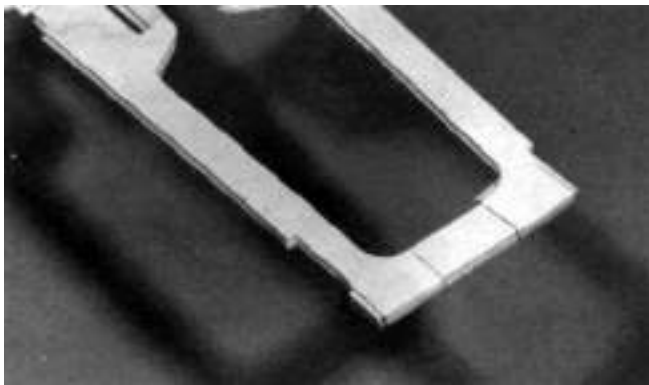

10. □ With the inlets face to face, tape the fuselage sides together at the rudder post end.

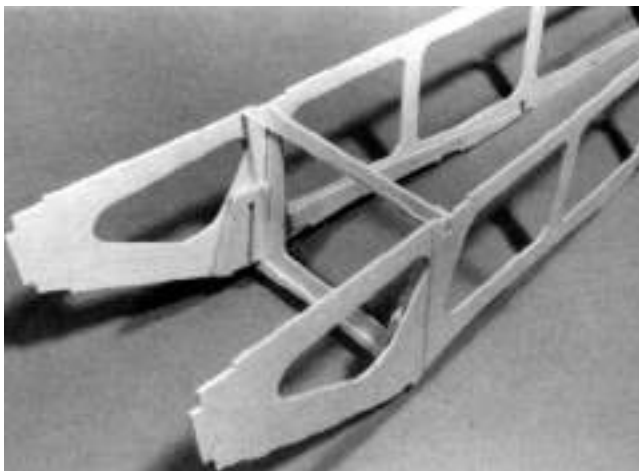

- Install former "B" (balsa doubler forward) and secure with a rubber band.

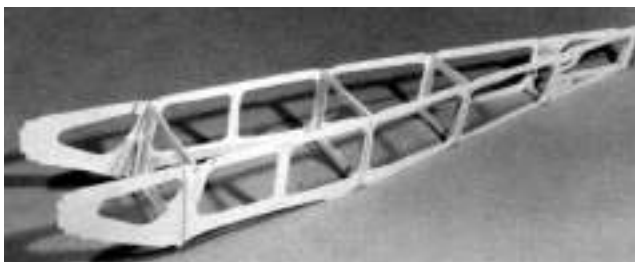

- Install formers "C," "D" and "E." Use a rubber band to secure at each former.

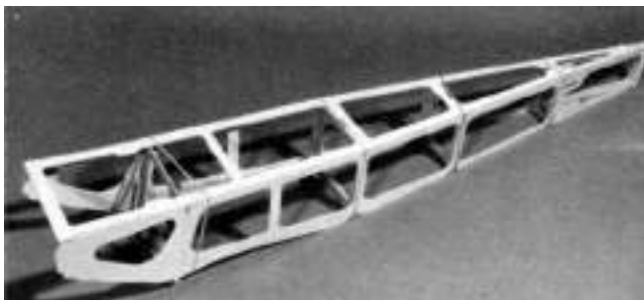

11. □ Slide the fuselage top under the rubber bands and press into position. Loosen the tape at the rudder post end to allow top to fit.

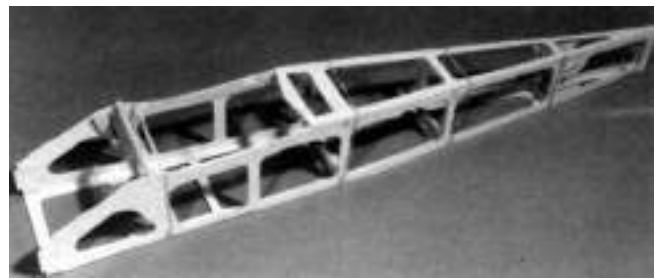

- Flip the fuselage over and install the bottom sheet.



- Position the fuselage over the TOP VIEW of the plan and check the alignment. Use small pieces of masking tape to secure the structure as you go.

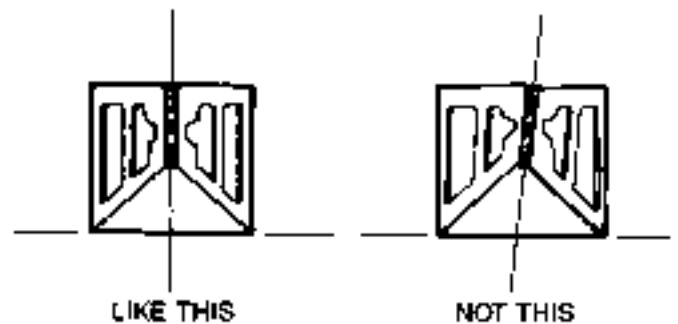

- Sight-check down the fuselage to insure against twist.



- When the fuselage is perfectly aligned, glue all of seams created by the sides, top, bottom and formers.

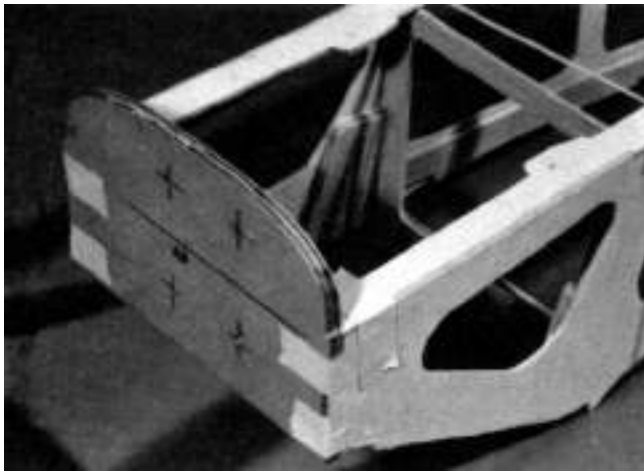

12. Glue the FIREWEALL onto the fuselage assembly. Make sure that the blind nut flanges are on the inside.

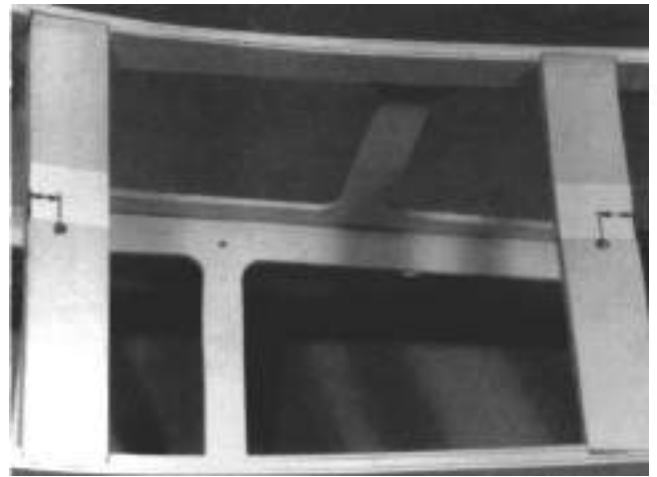

14. GENEROUSLY glue the basswood wing-mounting blocks to the fuselage sides.

REAL IMPORTANT!! Make sure that you install the mounting blocks correctly. The front block is longer than the rear block. The short distance from the edge, to the hole is FORWARD on the front block, and REARWARD on the rear block.

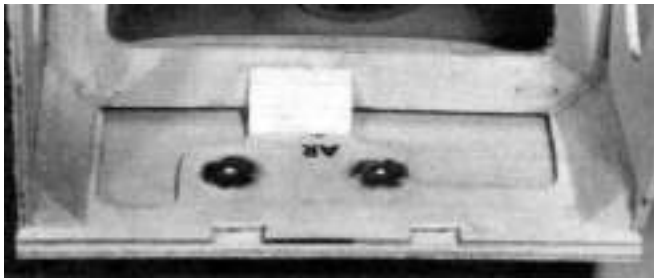

- Trim and glue the 1/2" balsa triangle stock behind the firewall (3 places).



15. Glue the landing gear block to the fuselage assembly. Make sure that the groove is facing out.

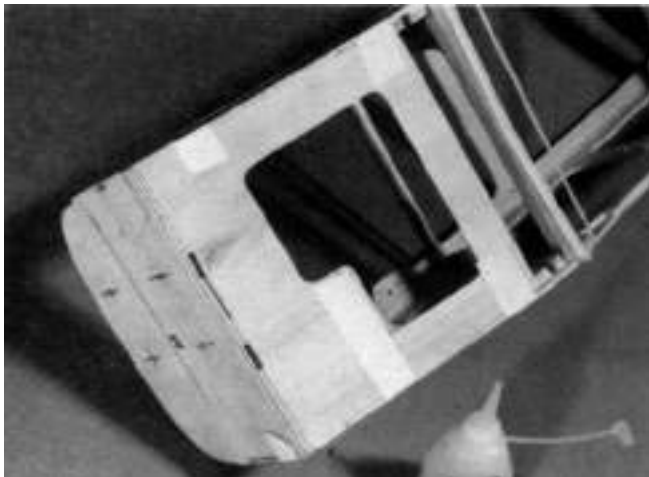

13. Glue the bottom-front piece in place.

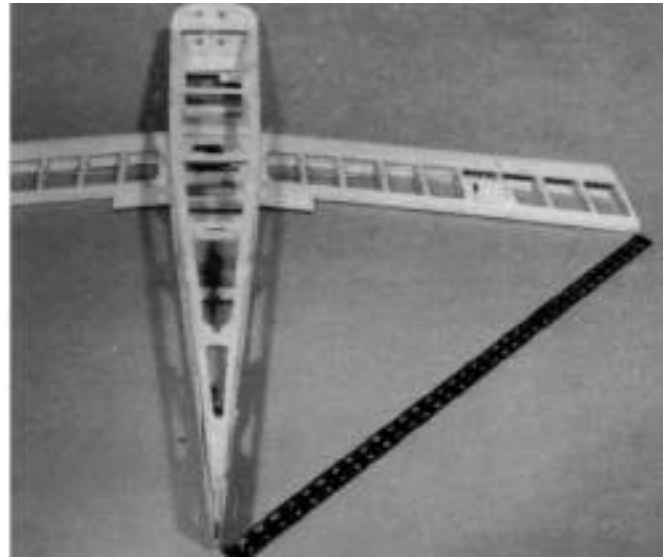
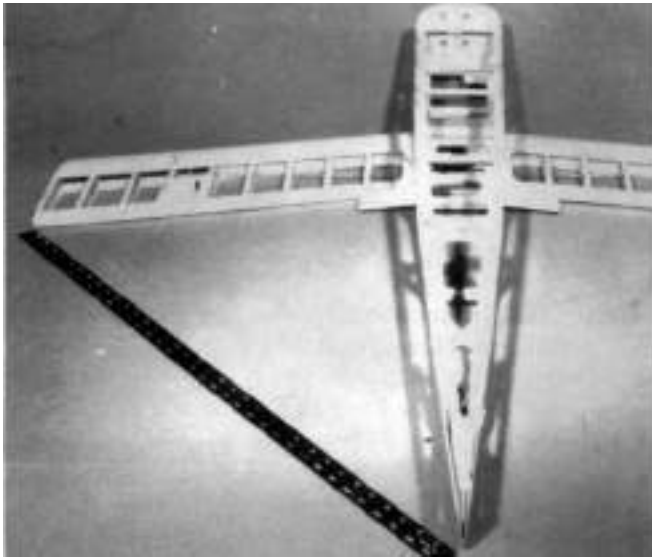

16. You will need the bottom wing for the next few steps.

- Place the bottom wing on a stable flat surface.
- Position the centerline of the fuselage over the centerline of the wing.
- True the wing to the fuselage by adjusting the distance from the wing-tip to the tail until both sides are equal. When you are satisfied, secure the wing to the fuselage with tape.



17. Using the predrilled holes, in the wing mounts, as a pilot/locator, drill a $5/32$ " hole through the wing at both the front and rear mounting blocks.



18. Insert a 6-32 blind nut into the top of each hole. Make sure that the spurs are into the wood. Tap with a hammer to insure a good fit.



19. Install the top formers. Formers "BB," "CC" and "DD" key into the fuselage top. Former "EE" fits directly above the main former "E" and must be held 90 degrees to the fuselage top.

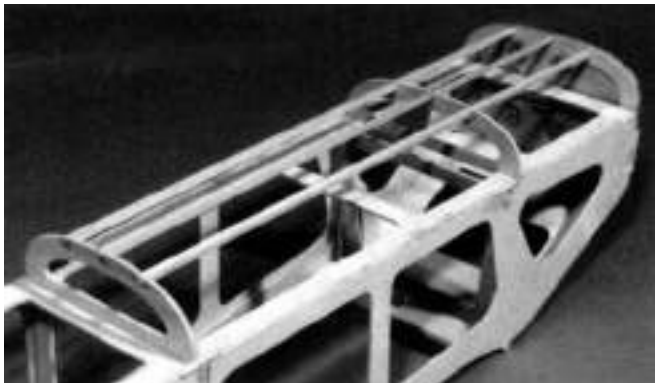

20. Install the two 3/16" sq. x 18" balsa stringers.
 Install the 1/8" x 3/16" x 18" balsa stringer.

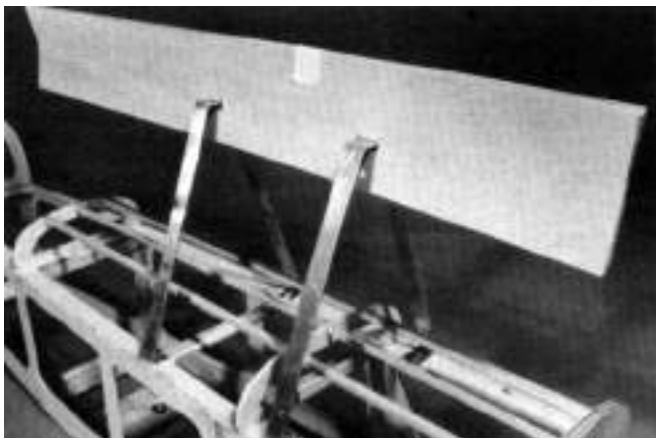

21. Slide the two 5/64" die-cut balsa front side sheets onto the cabane struts. Note that the pointed portion is on top and faces aft.

Tape the two sheets together on top of the cabanes.



22. Bolt the cabane to the fuselage top using four 4-40 x 3/8" socket head bolts, #4 washers and self-locking nuts.



23. Using a 5/64" balsa scrap as a gauge, glue the 1/8" sq. x 18" balsa back-up strip to the fuselage top.



24. Separate the front sheets, and glue them to the 1/8" sq. balsa back-up and fuselage side. Tape along the seam to secure until dry.

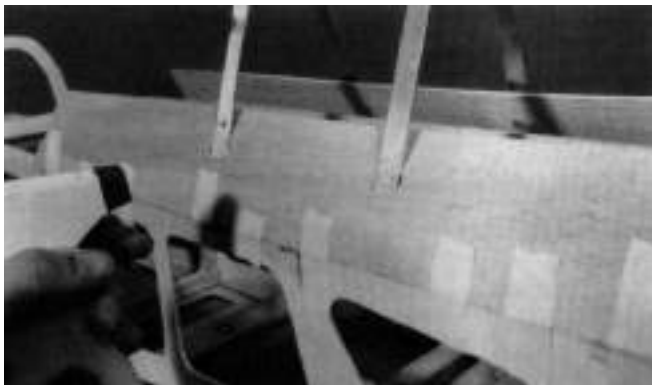

Fill an empty spray bottle with water, and soak the side sheeting the entire length along the bend. This will insure forming the sheeting without splitting.



Apply glue to the formers and to the edge of the 3/16" sq. stringer. Roll the sheeting onto the formers and the stringer. Sheeting should cover only half of the stringer. Tape down as you go.

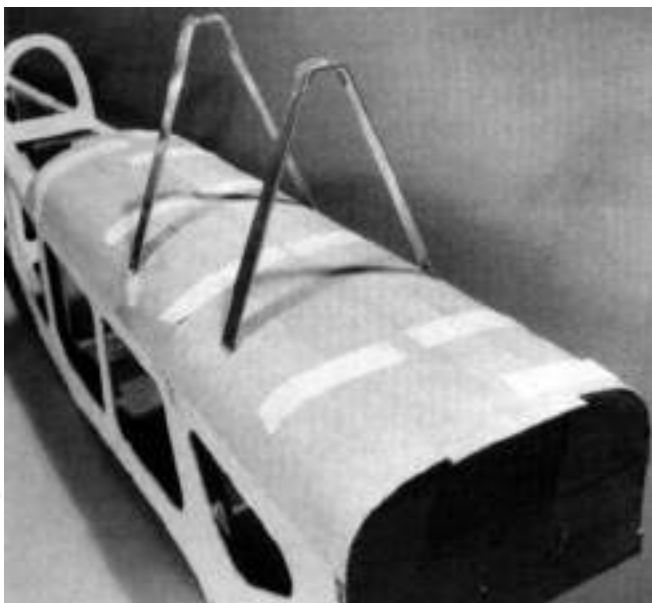

25. Test-fit the center sheet before applying glue. Trim to fit if needed. When you are satisfied with the fit, apply glue and permanently install.



26. Mark the centerline onto the horizontal stabilizer and the stab platform, on the fuselage.

Glue the stabilizer to the platform. Locating it on centerlines, and against the "EE" former. Check the stabilizer to insure that it is 90 degrees to the rudder post slot.

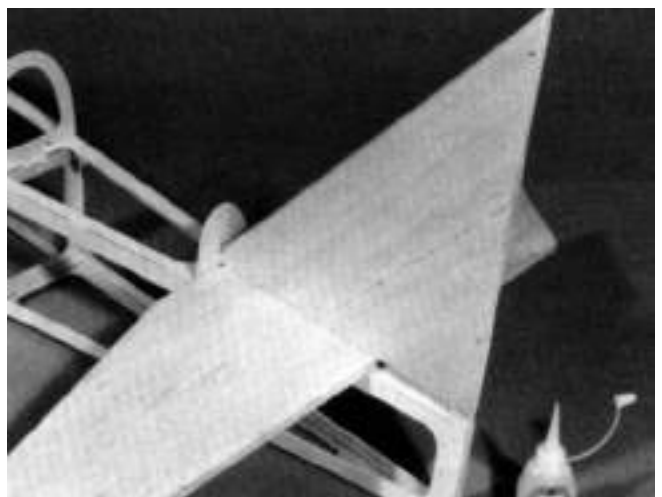

27. Install the vertical fin. Insert the rudder post into the rudder post slot. Tilt the fin forward placing the L.E. into the slot in former "EE."

Square the fin to the horizontal stabilizer with a 90 degree triangle.

Permanently glue the fin to the stabilizer and fuselage.



28. Slide the 1/32" ply turtledeck around the fin.
- Again, using the spray bottle, liberally soak the top centerline of the turtledeck. This will allow the plywood to be formed without splitting.
- Wrap the ply around the formers and down onto the fuselage sides. Check the fit-up around the stabilizer and the lap joint on the fuselage. Trim if needed, gaps will be filled with Model Mate later.



29. When you are satisfied with the fit, apply glue to the formers, fuselage sides, fin and stab.
- Quickly wrap the plywood down to the fuselage and tape in place until dry.

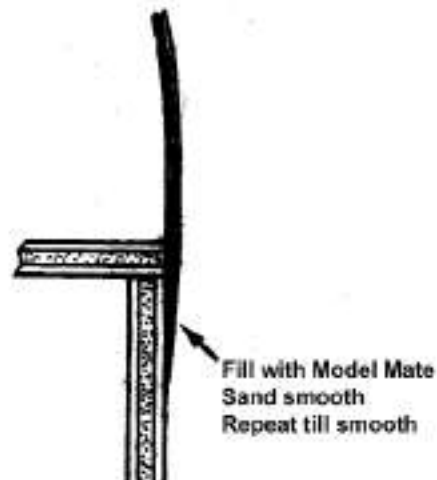

30. Bevel the plywood edge at the fuselage lap-joint.
- Fill in the step with Model Mate and sand smooth.
- Apply filler to the fin and stabilizer seams and blend to create a smooth transition.
31. Go over the fuselage and sand all seams and joints. Then sand the entire fuselage using "fine" sandpaper. This will insure a smooth surface and the covering will reflect this effort. Go back and finish sand all of the built-up parts. When you are satisfied with the finish you are then ready to cover them.

Look at the GENERAL INFORMATION BOOKLET and follow the covering instructions. Also read the instructions enclosed with the covering. This will help you to determine your course of action.

CONSTRUCTING THE INTERPLANE STRUT (6 Steps)

1/8" x 3/16" Balsa

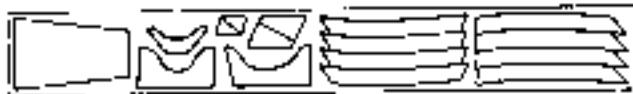

5310

PT #3277

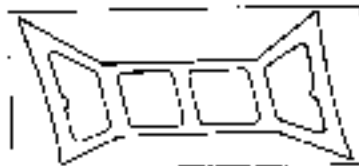

5309

PT #3465

1. Find all the parts that you will need to build both INTERPLANE STRUTS.

THEY INCLUDE:

- (2) STRUT FRAMES PLY (DIE SHT. #5309)
- (4) TOP DOUBLERS 3/16" Balsa
(DIE SHT. #5310)
- (4) BOTTOM DOUBLERS 3/16" Balsa
(DIE SHT. #5310)
- (2) 1/8" x 3/16" x 21" Balsa Stick

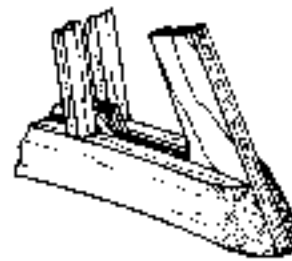

ROUND THE L.E.

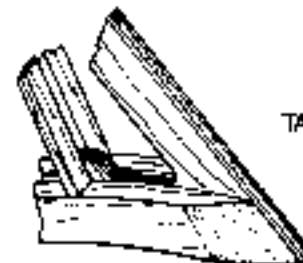

TAPER THE T.E.

5. Bevel the doublers back to the plywood frame at the trailing edges, and around the leading edges.
6. Go back and repeat steps 2 through 5. This will result in two complete struts, ready for covering.

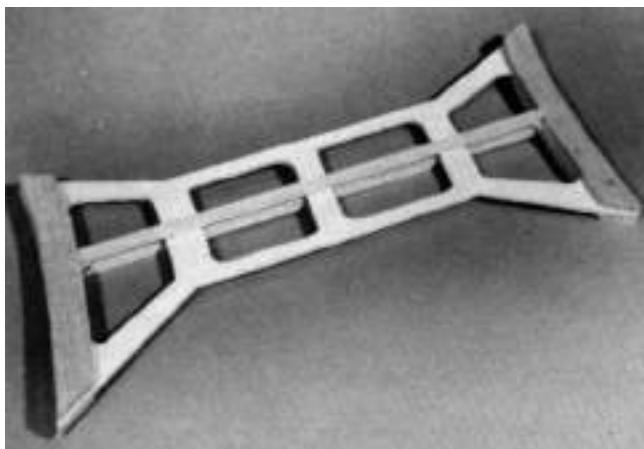

2. Glue the 3/16" balsa doublers to the plywood interplane frame, matching the curves.
3. Trim and glue the 1/8" x 3/16" balsa stick to the tabs on the ply interplane strut.
4. Flip the strut over and repeat steps 2 and 3.

ALIGNING THE WINGS

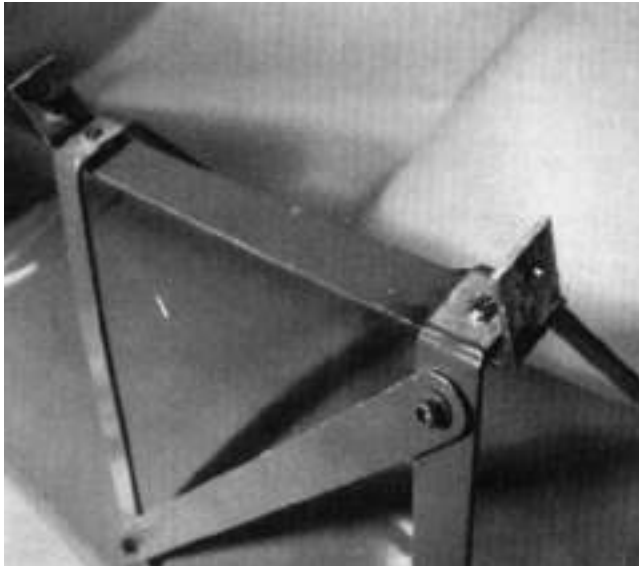

1. Bolt the formed top piece **UNDER THE CABANES** using two 4-40 x 1/2" machined head bolts with self-locking nuts.
 Bolt on the two diagonal struts using four 4-40 x 3/8" socket head bolts with self-locking nuts.

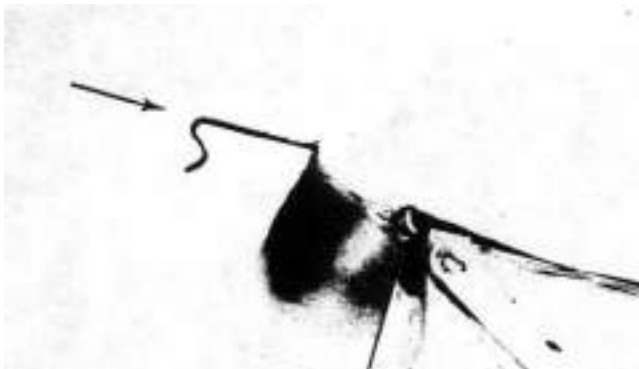

2. Install the top wing and insert the wing pin.

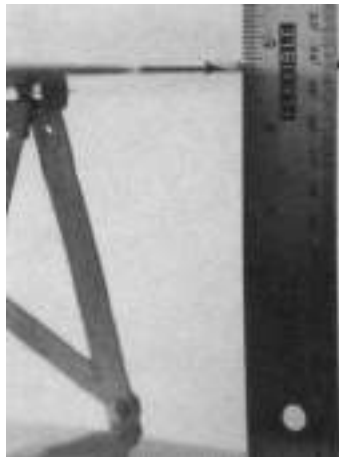
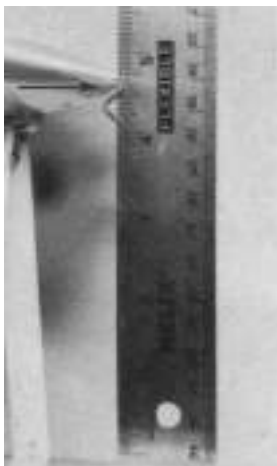

3. Check the wing alignment by measuring the distance from the top of the fuselage to the center of the L.E. and the T.E. These dimensions **MUST** be identical. If they do not match, shim the formed top piece until the dimensions are the same.

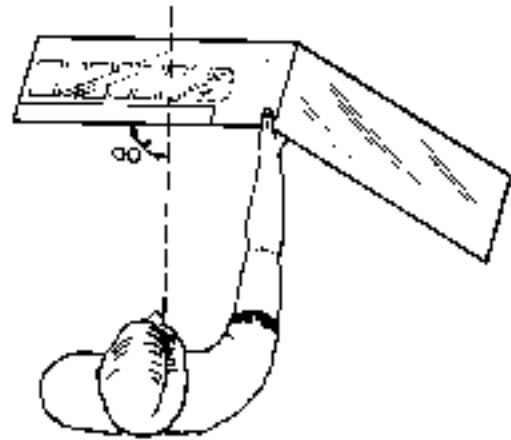

4. Sight the T.E. of both wings and check for warps.

If the wing is straight it will appear like this.



If the wing is warped, it will appear like this. Heat the warped panel and twist straight.

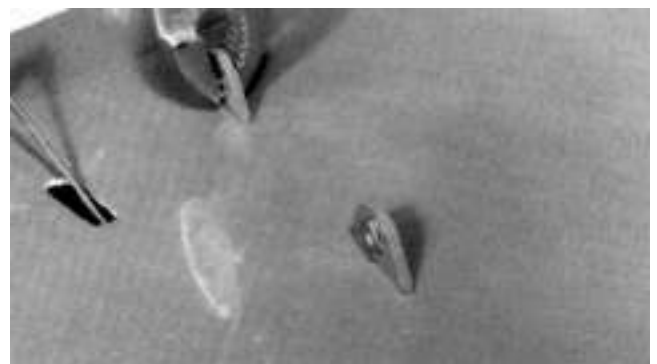
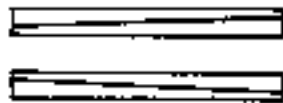

5. Install 4-40 blind mounting nuts into the holes in the strut mounting tabs.



6. Mark the hole locations onto the strut using the tabs as a template, and drill a 3/32" hole at each location.

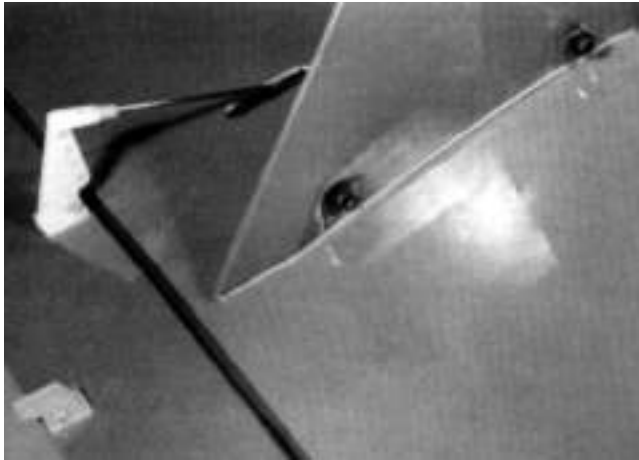

7. Bolt the strut to the top and bottom wing using four 4-40 x 3/4" socket head bolts with washers.

- Install the control horns and attach the pushrods using four 2-56 x 3/4" pan head screws.

- Trim the small control horn and attach it to the trailing edge of the ailerons using eight 2-56 x 1/2" pan head screws. Attach the aileron coupler pushrod. Make sure that the ailerons are correctly aligned with respect to the wing. (Servo must be in the neutral position with the trim tab centered.)

LANDING GEAR SKIRTS

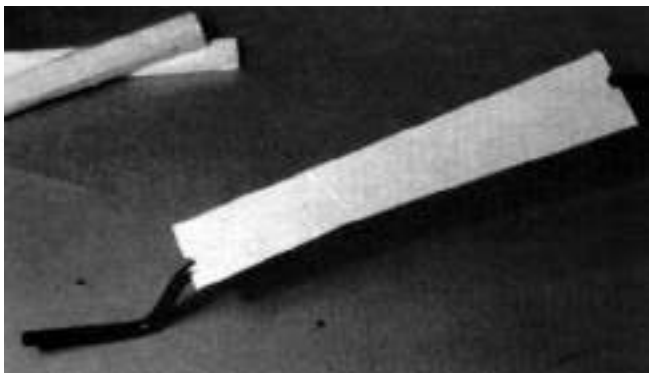

1. Align the notches on the 1/32" D.C. ply skirt with the wire landing gear. Note that the narrow end is at the axle and the angle is aft.



3. Trim off the excess using the plywood skirt as a template.

- Round off the sharp corners and cover.



3/16" x 1/2" Balsa

2. Glue 3/16" x 1/2" balsa to the ply on each side of the wire.

ASSEMBLING THE WHEEL PANTS



1. Clean up the edges of the pant halves by gently sliding them over sandpaper on a flat surface.



2. Drill a 3/16" hole at the axle location on the outer pant half.
 Glue the two support plates to the inner pant half.

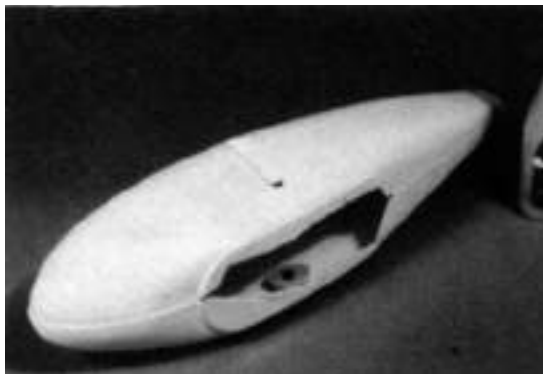

3. Rough-cut the wheel opening in all four pant halves, and glue an outer half to an inner half, forming a lap joint. Align the outer half edge to the scribe line on the inner half all around.
 Glue the axle support plate to the outer pant half, aligning the center mark on the plate concentric with the hole.
 Drill a hole completely through the pant.



4. Carefully trim to the wheel well line. Use a small round file to clean up the edges.
 Fill the step of the lap seam with Model Mate and sand smooth. Repeat if necessary.
 Repeat the process for the other wheel Pant.
 Paint the wheel pants.

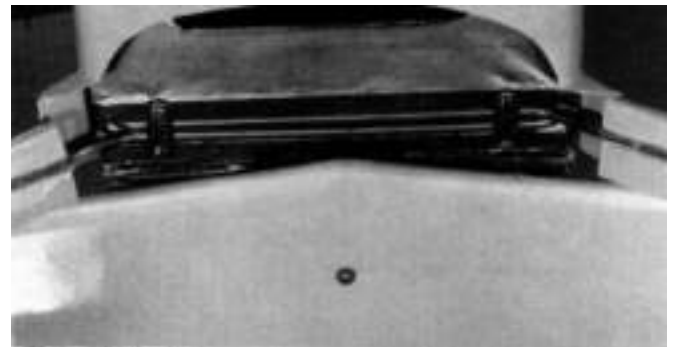

5. Install the landing gear by sliding each wire into the slot along the fuselage.
 Secure the two nylon landing gear straps and four #2 x 1/2" screws.
 Permanently install the skirts to the landing gear after the engine cowl is mounted. Use silicone adhesive to attach the skirts to the wire.

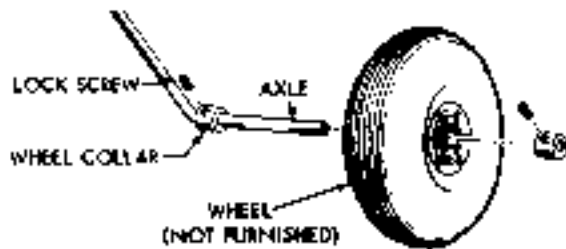

6. Slide the wheel part, collar, wheel and collar onto the landing gear axle.

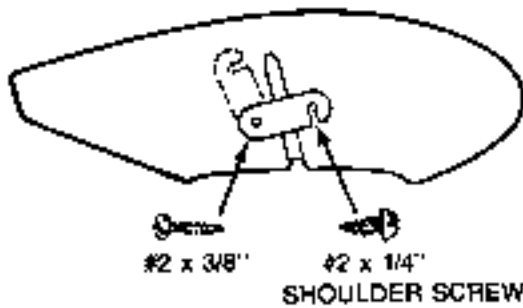

- Snap the landing gear into the part groove and permanently install the nylon strap.



- With the wheel in the center of the part, tighten set screws in the collars allowing the wheel to spin freely.

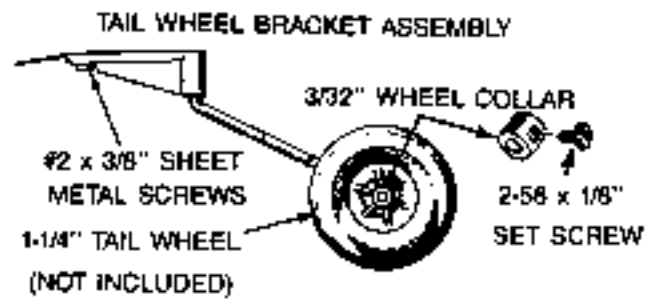

7. Install the tailwheel bracket. Secure using two #2 x 3/8" screws.

- Install a 1-1/4" diameter wheel.



- With the horn bracket on the wire, notch the bottom of the rudder and glue in the bracket.

FUEL TANK INSTALLATION

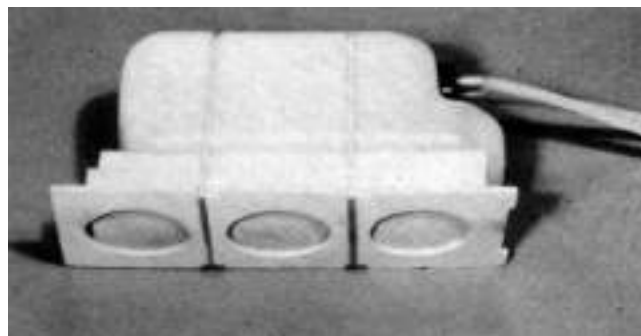

1. With a piece of foam rubber between the tank platform and the tank, rubberband all three together.



2. Attach the fuel lines and feed them through the opening in the firewall you need to make.

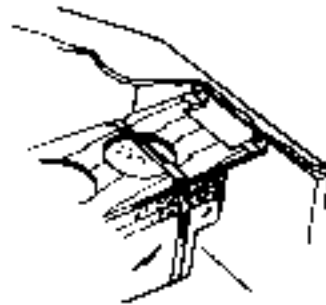

3. Slide the tank platform forward and insert the tabs into the notches in the firewall.

|| Glue a 1/8" x 1/2" balsa stick under the tank tray at the marks on former "B."

ASSEMBLING THE ENGINE COWL

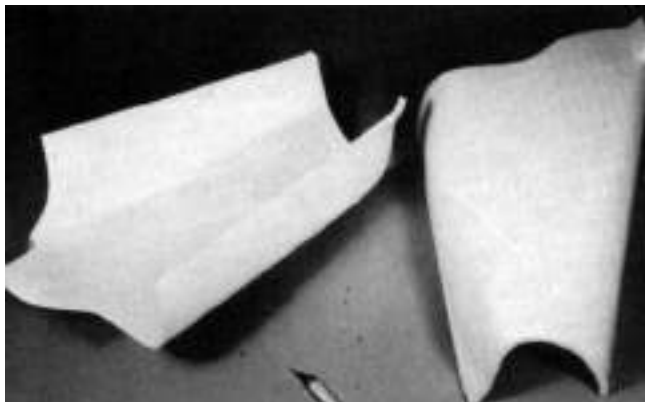

1. Carefully cut the cowl halves along the scribe lines around the perimeter. Sand the edges straight along the top and bottom seam line.
 Trim around the landing gear skirt fairings and underside exhaust opening.



3. Glue the front piece onto one of the sides. Tape together along the seam.



2. Cut out the two air intake openings on each side of the spinner ring along with the bottom opening and the prop shaft opening. Use a small round file to clean up the edges of each intake.

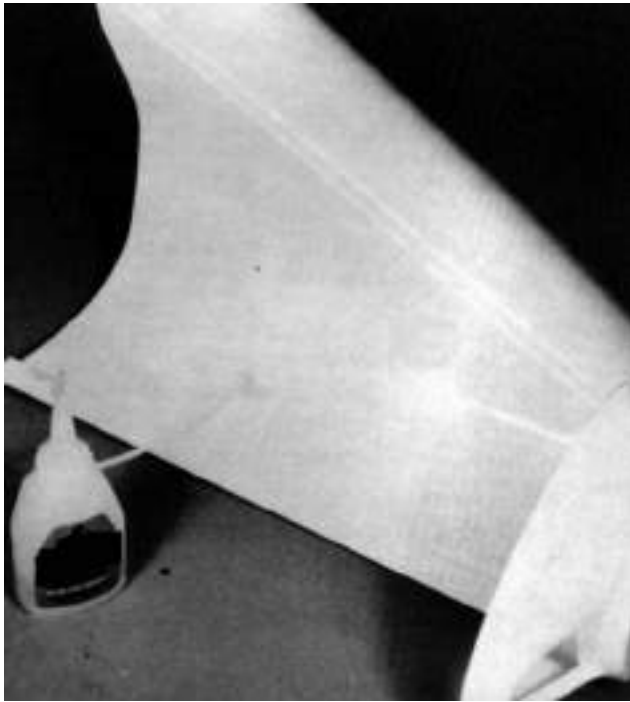

4. Glue the joiner strip to the top and bottom seam. Leave half of the strip width exposed to allow the other cowl half gluing surface.



5. Glue the remaining half to the front piece and onto the joining strip. Fit all seams as tight as possible. This will eliminate excessive filling and sanding the seam later.

Fill the seams with Model Mate and sand smooth

Paint the cowl using any of the following paints: PACTRA Formula "U," BLACK BARON Epoxy or HOBBY POXY.

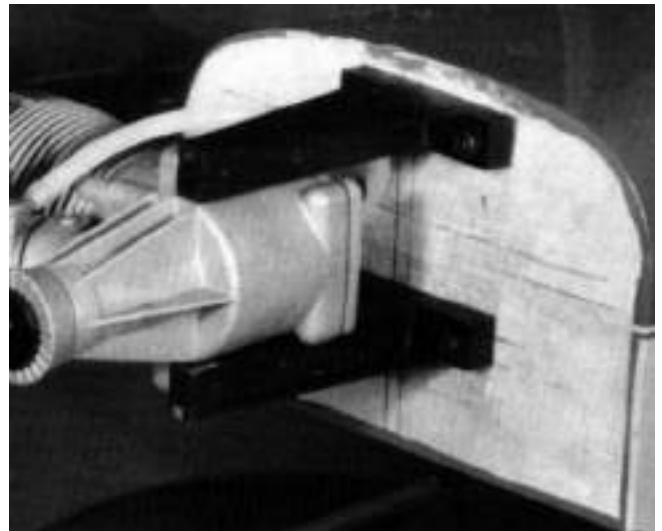

6. Permanently install the motor mounts to the firewall using four 6-32 x 1" socket head bolts with washers. Don't forget right thrust. Screw the engine to the mounts using four #6 x 3/4" screws with washers. (See step #4 in "Constructing the Fuselage" section.)

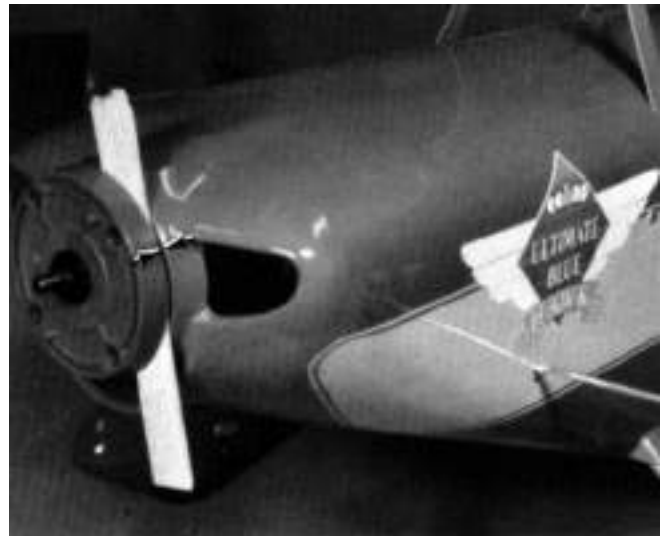

7. Slide the cowl on over the engine and install the spinner backplate on the prop-shaft.

Insert a 1/16" balsa scrap between the backplate and the cowl. Locate the cowl off the spinner backplate and attach to the fuselage using six #4 x 3/8" screws with washers. See plan for the location.

INSTALL THE CANOPY



- Peel and stick the instrument panel onto former "CC."
- You may wish to add a pilot as shown on the prototype model. Do so now, it does look good on the loooooowwww inverted fly-bys.
- Trim the canopy to the outer scribe line. Lightly sand the inside edge of the canopy and the covering under the glue joint. For added glue joint strength, make a series of pin-holes through the covering. This will allow the glue to penetrate into the wood beneath the covering.
- Make sure the canopy and the cockpit area are dustfree before gluing the canopy to the fuselage.
- Paint or cover the glue flange of the canopy.

RUDDER CABLES

A word here about the rudder actuation. The system used on the ULTIMATE is a "pull/pull" system. The rudder servo must be located as shown on the plans to insure the correct cable alignment with the cable exits. Solder the threaded coupler to the cables being careful to keep both assembly lengths equal. With the servo in the neutral position, trim tab centered, attach the cables to the control horn and to the servo arm. Adjust the snap-links until the rudder is perfectly straight. That's all there is to it!

A ball-bearing servo is recommended for the rudder control.

After you finish covering the entire model, permanently install the hinges. the GENERAL INFO BOOK covers this too.

CONTROL SURFACE TRAVELS

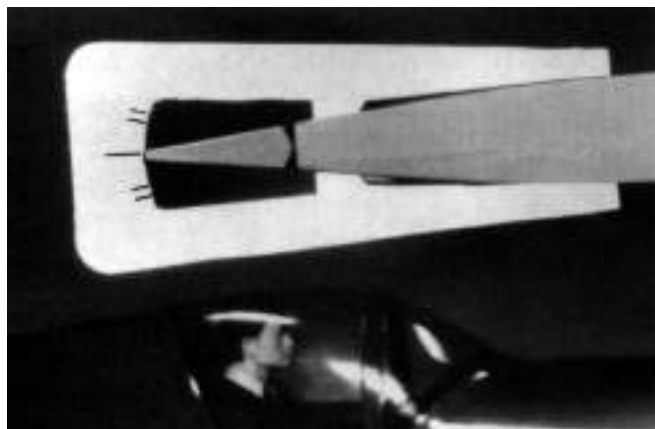

Use the control surface travel gauges provided in this kit (DIE SHEET #5303). The gauges provide you with two measured angle deflections: Gentle response and a quicker Aerobatic mode. We encourage you to start out with the Gentle settings no matter what your flying level may be and move into the Aerobatic settings. The angle measurements that the gauges reflect are:

Note: Always use the furthest hole on all control surfaces and adjust at the servo for proper throw. Do not use the transmitter adjustment to set up the control travels. Fine tune at the transmitter only.



	SETTINGS	
	GENTLE	AEROBATIC
AILERONS	10°	12°
ELEVATOR	12°	14°
RUDDER	15°	23°

It is not recommended that you fly this model with the dual rate control HIGH RATES set at the "aerobatic settings" and the LOW RATES set at the "gentle settings." The initial flights should be set-up with the "gentle settings" at the HIGH RATE and the "LOW RATES" 75% of the "gentle settings." The full F3A schedule can be flown very well with this set-up. Once the model is trimmed out and then if you want a more "hot dog" style of flying, then increase the control travels with the same percent of LOW RATE.

If you fly with a Futaba computer radio, then you might want to try a 6% mix as follows.

RUDDER	AILERON
LEFT RUDDER	RIGHT AILERON
RIGHT RUDDER	LEFT AILERON

The prototype model showed no "pitch" mix requirements.

Futaba also offers a VTR, which is similar to EXPO but probably better. The set-up is as follows:

D/R		VTR	
AILERONS	85%	AILERONS	100%
ELEVATOR	75%	ELEVATOR	100%
RUDDER	65%	Use D/R only on rudder.	

OPTIONAL INSTALLATION

IF YOU WISH TO INSTALL AN INDIVIDUAL AILERON SERVO MOUNTING SYSTEM, THE DRAWING BELOW ILLUSTRATES A SIMPLE AND SECURE METHOD OF INSTALLING A SERVO OUT IN THE WING TO DRIVE THE LEFT AILERONS AND A SERVO TO DRIVE THE RIGHT AILERONS. ELECTRONIC MIXING IS THEN USED TO OBTAIN THE CONTROL AND DIFFERENTIAL REQUIRED.

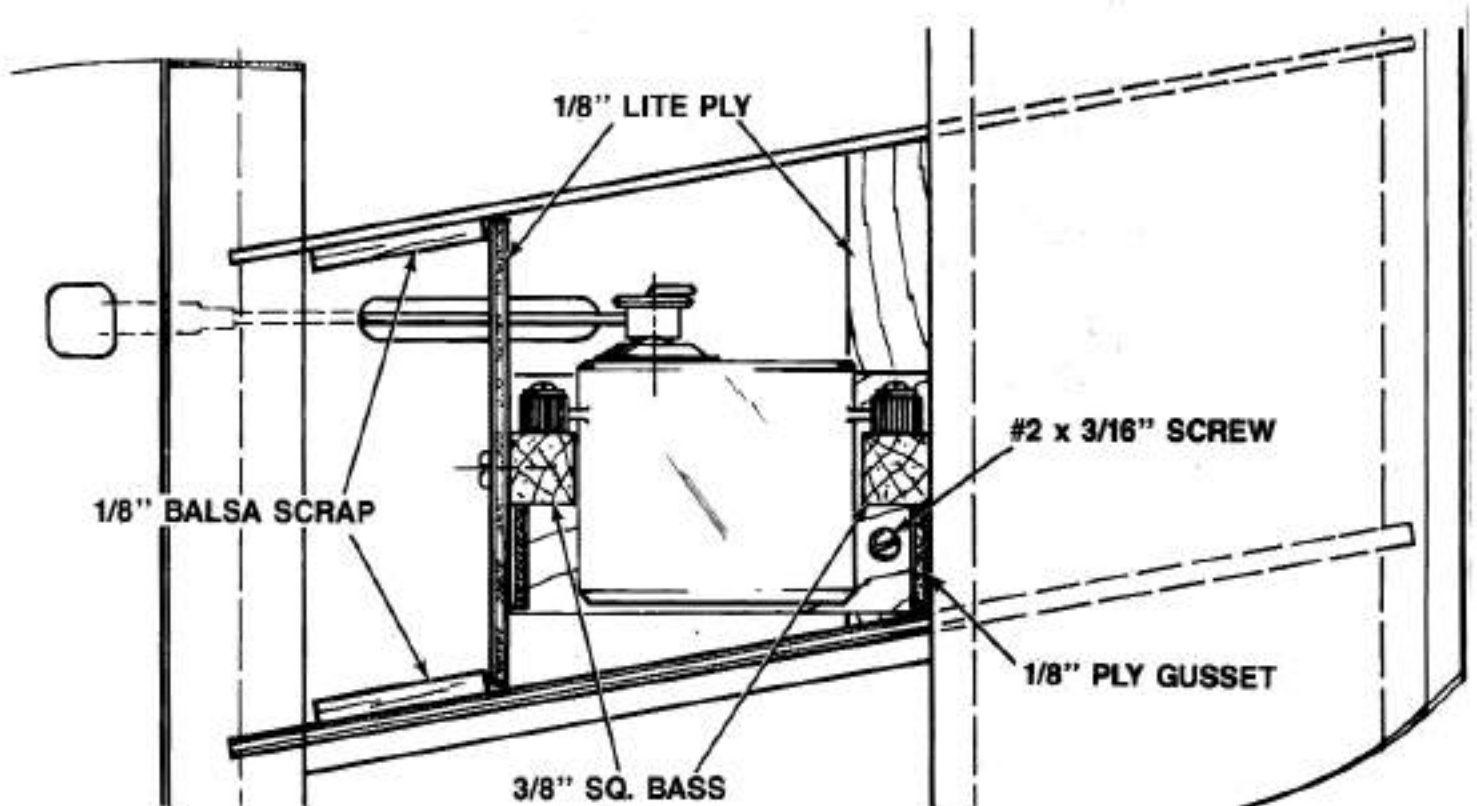
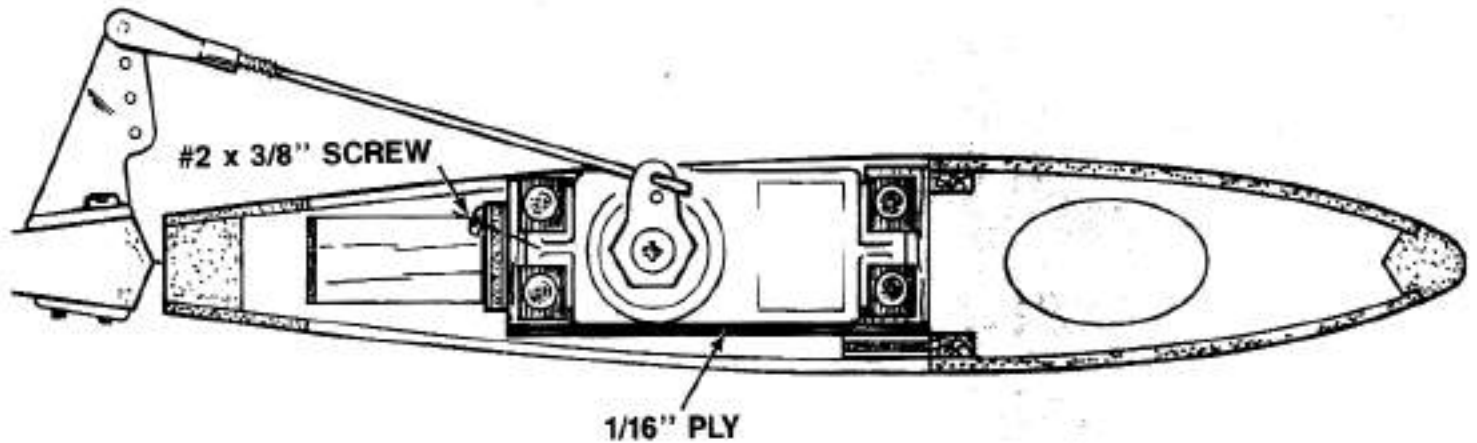

YOU WILL NEED TO CUT OUT A FEW ADDITIONAL PARTS, AND CONSTRUCT TWO TRAYS TO SUPPORT THE SERVOS. IN ADDITION YOU WILL NEED TO RELOCATE THE PUSHROD EXITS IN THE WING SHEETING. OH, AND DON'T FORGET TO LACE THE SERVO WIRE THROUGH THE WING. (YOU WILL ALSO NEED A SERVO WIRE EXTENSION.)

IF YOU WANT TO ADD A TUNED PIPE TO THE "ULTIMATE," WE SUGGEST THE FOLLOWING INSTRUCTIONS:

THE PURPOSE FOR SHROUDING THE TUNED PIPE IS TO PROVIDE A CONTROLLED AIRFLOW, TO COOL THE PIPE AND TO PROTECT THE FUSELAGE INTERIOR FROM THE HEAT AND OIL.

IT IS STRONGLY RECOMMENDED THAT THE PLYWOOD TUBE BE FUEL-PROOFED. POLYESTER RESIN WORKS VERY WELL FOR THIS APPLICATION.

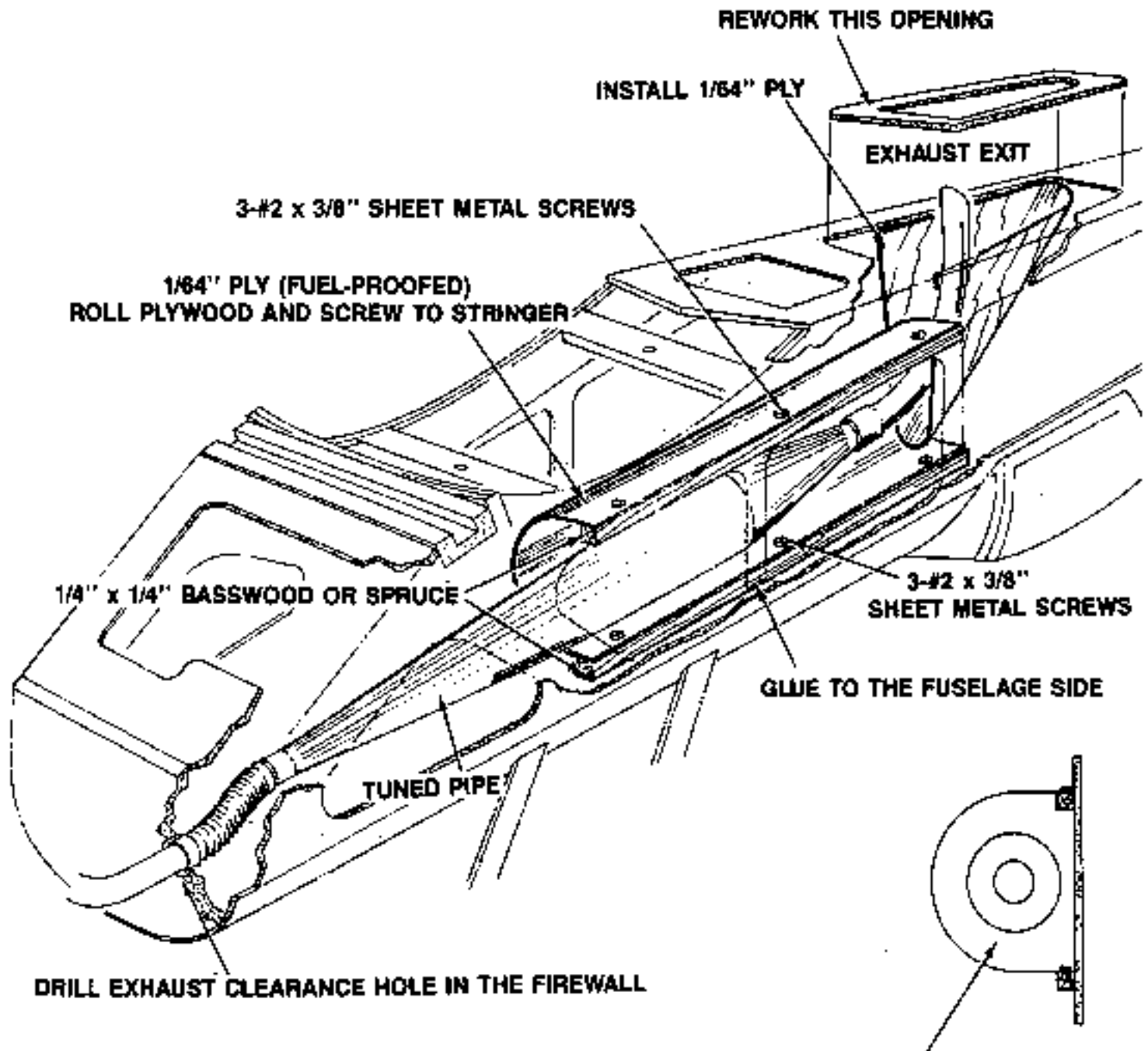

AT LEAST 1/2" SPACE SHOULD BE MAINTAINED BETWEEN THE TUBE AND THE TUNED PIPE AROUND THE ENTIRE CIRCUMFERENCE.

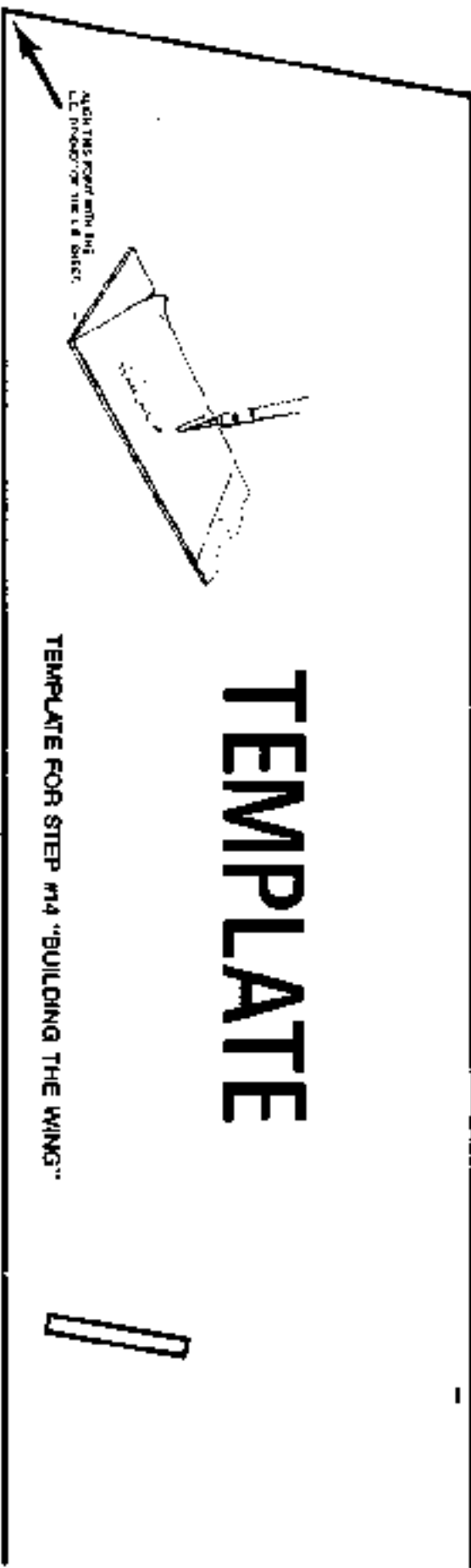

TEMPLATE

TEMPLATE FOR STEP #14 "BUILDING THE WING"



TEMPLATE

TEMPLATE FOR STEP #14 "BUILDING THE WING"

ADVANCED AEROBATICS

Developing your flying skills to do more varied maneuvers is exciting and rewarding. The Ultimate is an extremely capable machine able to do some unusual stunts. Here are a few examples you might try out.

KNIFE-EDGE LOOP (You will need a very powerful engine such as a Y.S 120)

Roll to the left or right and hold a bit (10%) of top rudder. When ready to start the loop, add more rudder.

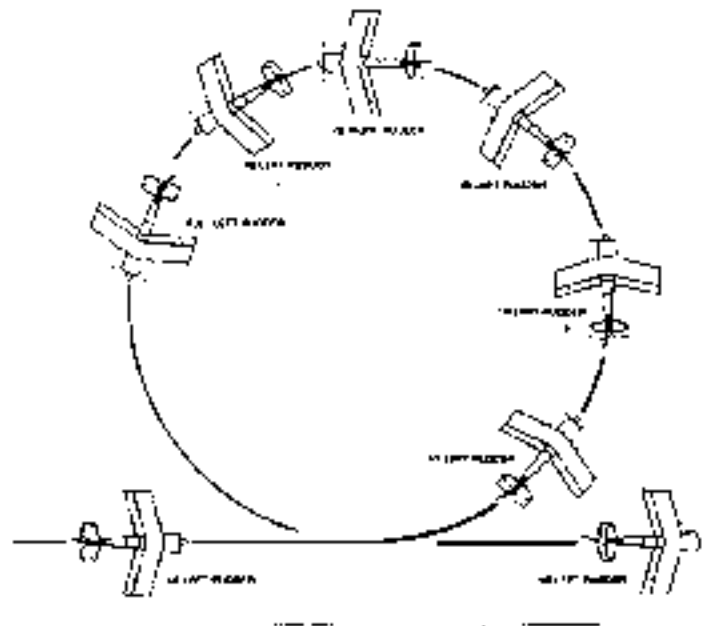

LOMCEVAC

Start out in a 45 degree climbing knife-edge. If you are using left rudder for the knife edge, then snap-rolf left (full left rudder and left ailerons and up elevator) 1-1/2 turns, then holding full left rudder, give full down and right aileron. Timing is the key as well as power and climb angle. Try it and hold on.

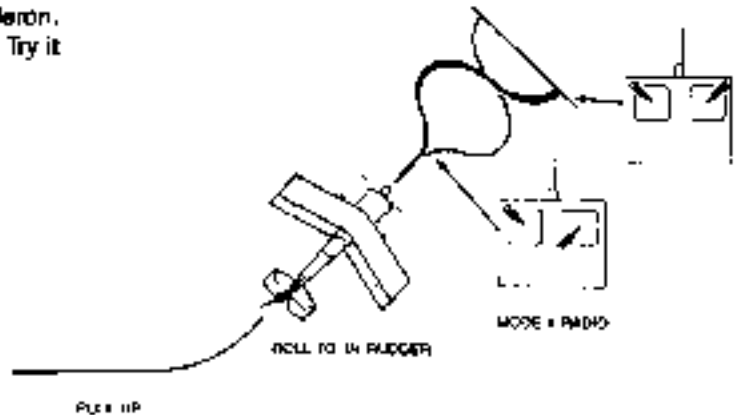

TAKE-OFF AND LANDING

Though the Ultimate is not difficult to take-off or land, care should be taken not to over-control. Make small smooth corrections until you become familiar. When taking off, you will need to add a bit of right rudder. Wait until there is plenty of airspeed and gently rotate (about 1/8-1/4 up elevator), keeping the wings level.

On landings you will find that the Ultimate glides better than most bi-planes, but remember that bi-ees don't glide as well as monoplanes. For the best landings, approach the runway at high idle and go low idle about 1 foot above the ground, starting to a 3 point landing as you gently touch down.