

P-51D MUSTANG



WARRANTY.....Top Flite Models guarantees this kit to be free of defects in both material and workmanship at the date of purchase. This warranty does not cover any component parts damaged by use or modification. In no case shall Top Flite's liability exceed the original cost of the purchased kit. Further, Top Flite reserves the right to change or modify this warranty without notice.

In that Top Flite has no control over the final assembly or material used for final assembly, no liability shall be assumed nor accepted for any damage resulting from the use by the user of the final user-assembled product. By the act of using the user-assembled product the user accepts all resulting liability.

If the buyer is not prepared to accept the liability associated with the use of this product, he is advised to immediately return this kit in new and unused condition to the place of purchase.



**Top Flite Models
3002 N. Apollo Dr., Suite 1
Champaign, IL 61822**

Technical Assistance - Call (217) 398-8970

READ THROUGH THIS INSTRUCTION BOOK FIRST. IT CONTAINS IMPORTANT INSTRUCTIONS AND WARNINGS CONCERNING THE ASSEMBLY AND USE OF THIS MODEL.

TABLE OF CONTENTS

METRIC CONVERSION CHART	2	Operational Flaps	46
INTRODUCTION	3	FINISHING	49
Precautions	3	Final Sanding	49
DIE PATTERNS	4,5	Fuelproofing	49
DECISIONS YOU MUST MAKE EARLY IN THE BUILDING SEQUENCE	6	Balancing the Plane Laterally	49
Engine and Mount Selection.....	6	Covering	49
Supplies and Tools Needed	6	Apply Trim	50
Other Items Required	7	Exhaust Stacks.....	51
Common Abbreviations	7	Apply Decals	51
Types of Wood.....	7	Hinging	51
Tips for Competition-Minded Modelers ..	7	Final Control Hardware Hookup	52
GET READY TO BUILD	8	Mount the Landing Gear.....	53
Build the Tail Surfaces	8	Fixed Landing Gear	53
Build the Fin	11	Retracts	53
Build the Rudder.....	12	Cockpit Finishing	53
Build the Wing	13	Install Receiver, Switch and Battery	54
Join the Wing Panels.....	18	Balance Your Model.....	54
Sheet the Wing.....	21	Final Hookups and Checks.....	55
Build the Fuselage.....	25	Control Surface Throws	55
Tips for Silver Soldering	28	PRE-FLIGHT	56
Mount the Wing to the Fuselage.....	32	Charge the Batteries	56
Attach the Stab and Fin	34	Find a Safe Place to Fly	56
Prepare the Elevators	36	Ground Check the Model.....	56
Fuselage Completion.....	37	Range Check your Radio.....	56
Install the Dorsal Fin.....	40	Engine Safety Precautions	56
Make the Top Cowling	41	AMA SAFETY CODE	56
Mount the Cowling.....	43	General	56
Build the Wing Fillet.....	43	Radio Control	57
Install the Forward Wing Fairing	45	FLYING	57
Fit the Radiator.....	46	2-VIEW DRAWINGS	60

METRIC CONVERSIONS

1" = 25.4 mm (conversion factor)

1/64" = .4 mm
1/32" = .8 mm
1/16" = 1.6 mm
3/32" = 2.4 mm
1/8" = 3.2 mm
5/32" = 4 mm
3/16" = 4.8 mm
1/4" = 6.4 mm
3/8" = 9.5 mm
1/2" = 12.7 mm
5/8" = 15.9 mm
3/4" = 19 mm
1" = 25.4 mm
2" = 50.8 mm
3" = 76.2 mm
6" = 152.4 mm
12" = 304.8 mm
15" = 381 mm
18" = 457.2 mm
21" = 533.4 mm
24" = 609.6 mm
30" = 762 mm
36" = 914.4 mm

WARNING! THIS IS NOT A TOY!

The model you will build from this kit is not a toy! It is capable of serious bodily harm and property damage. **IT IS YOUR RESPONSIBILITY AND YOURS ALONE** - to build this kit correctly, properly install all R/C components to test fly the model, and fly it **ONLY** with experienced, competent help in accordance with all safety standards as set down in the Academy on Model Aeronautics Safety Code. It is suggested that you join the AMA to become properly insured before you attempt to fly the model. **IF YOU ARE JUST STARTING R/C MODELING, CONSULT YOUR LOCAL HOBBY SHOP OR WRITE TO THE ACADEMY OF MODEL AERONAUTICS TO FIND AN EXPERIENCED INSTRUCTOR IN YOUR AREA.**

**Academy of Model Aeronautics
5151 East Memorial Dr.
Muncie, IN 47302-9252 (800) 435-9262**

INTRODUCTION

Thank you for purchasing the **Top Flite GOLD EDITION P-51D Mustang**.

The Top Flite P-51D is an excellent sport scale model that is just as "at home" with sport flying as it is in competition. Its exact scale outline allows you to add authentic details and take it into serious competition if desired. Its modern construction and refined aerodynamics, incorporating features such as computer-designed airfoils that progressively change from root to tip with built-in washout, give you a plane that will build straighter and fly better than warbird kits of the past.

The **Gold Edition** Mustang is approximately 1/7th scale. The exact scale ratio is 1: 6.83. The trim scheme allows you to finish a very impressive model using Top Flite Super MonoKote®. The MonoKote covered prototype, shown on the box, was good enough to finish 2nd in Expert at the very competitive 1992 **Blue Grass Scale Classic** in Kentucky. It scored quite

well in static due to its excellent outline, and posted the highest flight scores in the expert category. This performance earned the Mustang an invitation to the **1992 Scale Masters**.

Please inspect all parts carefully before starting to build! If any parts are missing, broken or defective, or if you have any questions about building or flying this model, please call us at (217) 398-6300 and we'll be glad to help. If you are calling for replacement parts, please look up the part numbers and the kit identification number (stamped on the end of the carton) and have them ready when calling.

PRECAUTIONS

1. You must build the plane **according to the plans and instructions**. Do not alter or modify the model, as doing so may result in an unsafe or unflyable model. In a few cases the plans and instructions may differ slightly from the photos. In those instances you should assume the plans and written instructions are correct.

2. You must take time to **build** straight true and strong.
3. You must use a proper R/C **radio** that is in first class condition, the correct sized **engine** and correct **components** (fuel tank, wheels, etc.) throughout your building process.
4. You must properly **install** all R/C equipment and other components so that the model operates properly on the ground and in the air.
5. You must **test** the operation of the model before the first and each successive flight to insure that all equipment is operating, and you must make certain that the model has remained structurally sound. Be sure to check external nylon clevises often, and replace any that show signs of wear.
6. If you are not already an experienced R/C pilot at this time, you must **fly** the model **only with the competent help** of a well experienced R/C pilot .

NOTE: We, as the kit manufacturer, can provide you with a top quality kit and thorough instructions, but ultimately the quality and flyability of your finished model depends on how you build it; therefore, we cannot in any way guarantee the performance of your completed model, and no representations are expressed or implied as to the performance or safety of your completed model.

Remember: Take your time and follow directions to complete a well-built model that is straight and true.

DIE-CUT PATTERNS

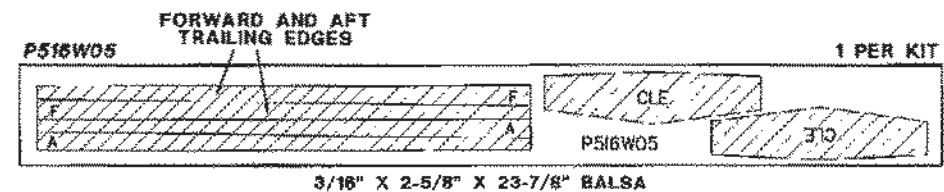
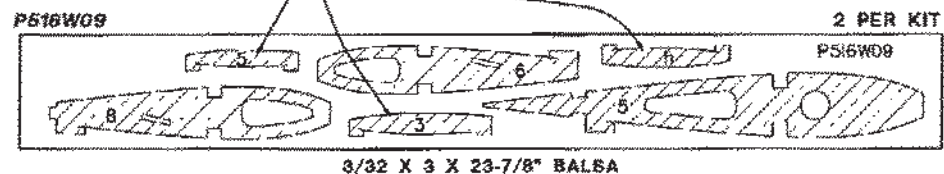
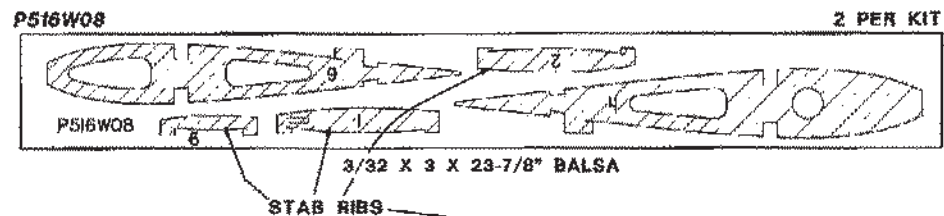
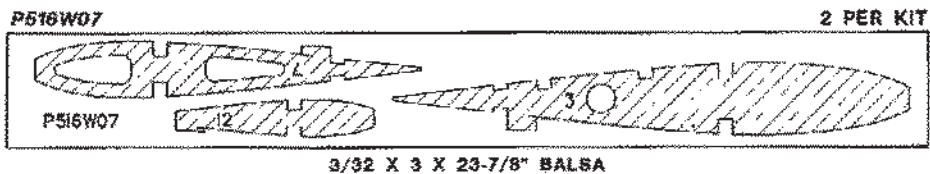
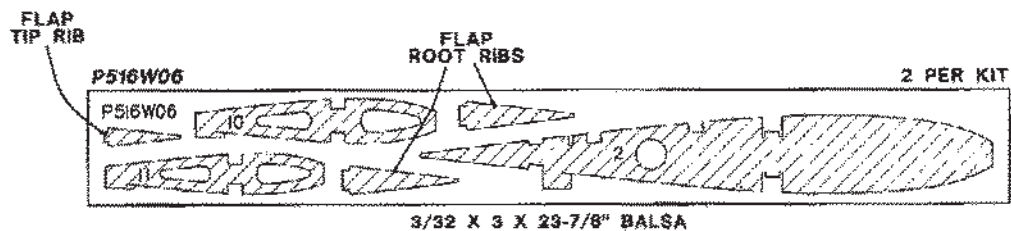
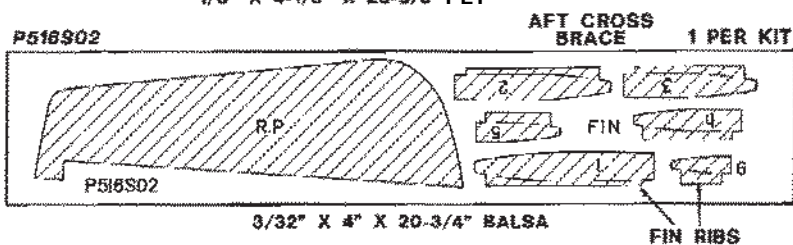
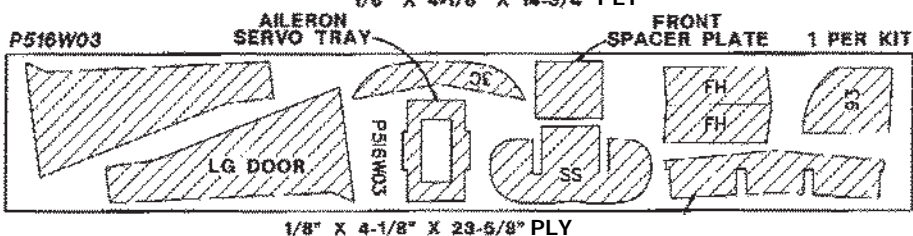
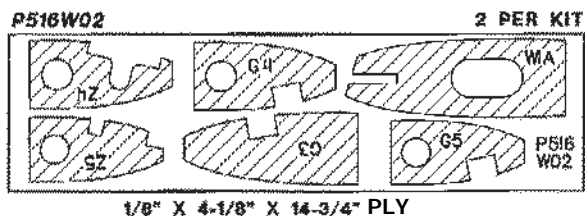
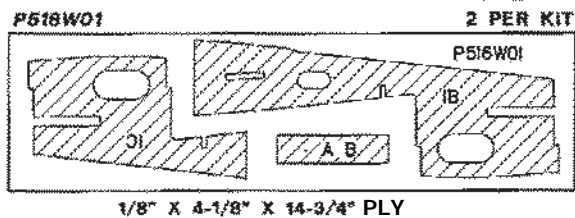
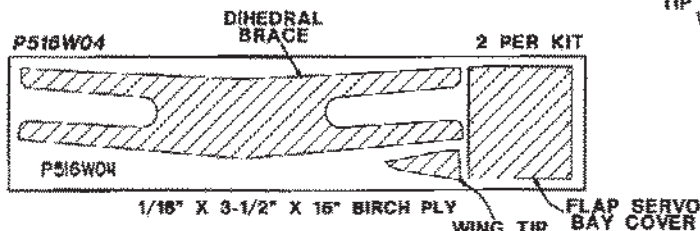

DIE-CUT PATTERNS

P516F01

1 PER KIT

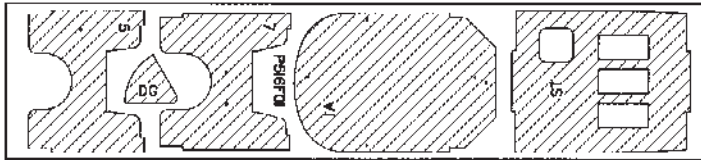

1/8" X 5-1/8" X 22-7/8" PLY

P516F06

1 PER KIT

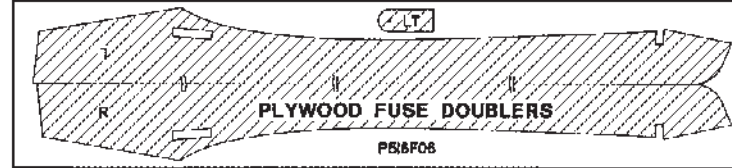

1/8" X 5-1/2" X 23-3/4" PLY

P516F02

1 PER KIT

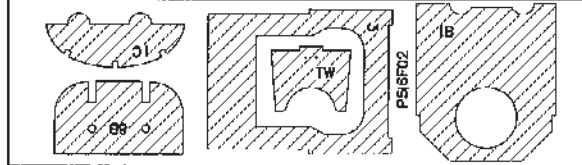

1/8" X 5-1/2" X 18-7/8" PLY

P516F08

1 PER KIT



1/32" X 21-1/4" X 3-3/4" BIRCH PLY

P516F03

1 PER KIT

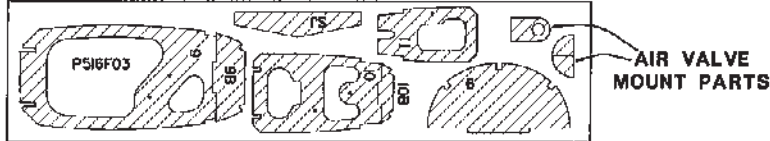

1/8" X 4-5/8" X 18-7/8" PLY

P516F09

2 PER KIT



1/8" X 3" X 24" Balsa

P516F04

1 PER KIT

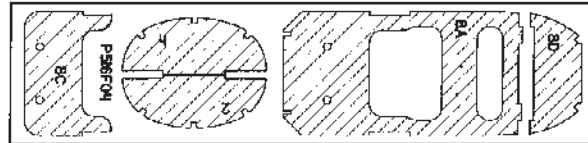

1/8" X 4-5/8" X 18-7/8" PLY

P516F10

2 PER KIT



1/8" X 3-1/2" X 18-7/8" Balsa

P516F13

2 PER KIT

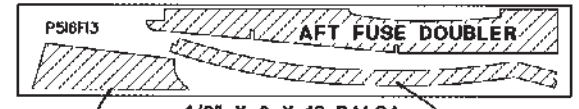

FORWARD FUSE DOUBLER

1/8" X 3" X 18" Balsa

RADIATOR KEEL

P516F05

1 PER KIT

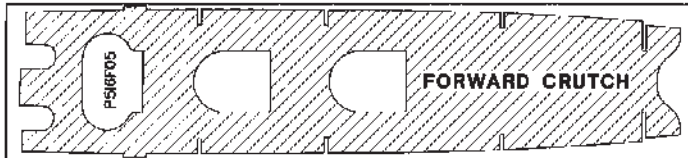

1/8" X 5-1/8" X 22-3/8" PLY

P516F11

2 PER KIT



1/8" X 3" X 24" Balsa

ANTENNA

1 PER KIT

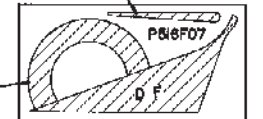

SPINNER RING

1/16" X 3-7/8" X 7-3/8" BIRCH PLY

P516F12

2 PER KIT

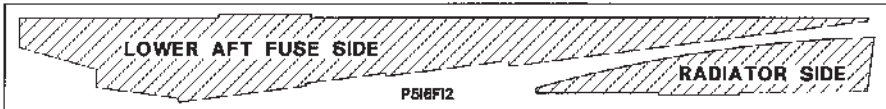

1/8" X 3-1/2" X 28" Balsa

P516S01

1 PER KIT

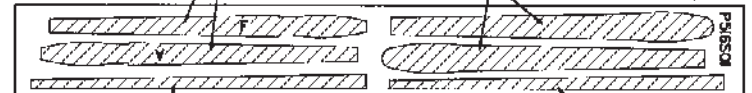

1/4" X 3" X 23-3/4" Balsa

DECISIONS YOU MUST MAKE EARLY IN THE BUILDING SEQUENCE

ENGINE AND MOUNT SELECTION

The recommended engine size range is as follows:

- .60 to .91 cu. in. (10cc to 15cc) **2-cycle**
- .90 to .120 cu. in. (15cc to 20cc) **4-cycle**

The Mustang will fly well with any of the recommended engines. The 4-cycle engines and most .90 2-cycle engines will turn a larger prop at lower RPM's. This is often desirable for scale realism. Many .60 2-cycle engines produce about as much horsepower as the popular .90 2-cycle engines and will fly the Mustang fine. If you use a .60 2-cycle, a Schnuerle ported engine is preferred.

If you will be side mounting your engine, the 2-cycle engines will not stick out of the cowl as much as 4-cycles will. If you mount your engine inverted, you will need to provide ample cooling air entry and exit areas.

This kit includes an EM60120 engine mount that will hold most engines in the recommended size range. The Top-Flite In-Cowl exhaust system works very well in the Mustang when the engine (2-Stroke) is mounted inverted.

RETRACTS

The choice whether or not to use fixed gear or retracts is up to you. Retracts offer good looks and great flight realism at the cost of some expense and complication. For sport flying and moderate competition work we recommend you choose an air operated system such as the Robart #605 90-degree retracts.

These offer the easiest installation and reliable operation. Mechanical retracts could be fitted, but the length and weight of the tire/strut assembly would overload most servos. More information on retracts is found in the "Tips for Competition-Minded Modelers" section and in the construction sequence. A Robart retractable tail gear will work well and may be mounted to F-10 (you must modify the lightening holes in F-10). You must actuate the tail gear retract with a servo or a 3/8" air cylinder and add a pull-pull tail wheel steering system to your model. Century Jet Models also offers a retract/strut package that is specifically tailored for the P-51.

WHEEL SELECTION

The scale tire size is 4". The recommended range of tire sizes is 3-1/4" to 4". If you use fixed gear, you may choose to use the smaller tires to reduce drag in the air. If you use 3/8" offset Robostruts, they are only available to fit up to 3-1/4" tires at the time of this writing. Robart main wheels are very close to scale for a P-51. A 1-1/4" tail wheel is scale and recommended.

FLAPS

This model is designed with all the provisions in place to include operating flaps that are very scale. They require some craftsmanship and time but are not very difficult to install, if you follow the instructions. They enhance the model's flight characteristics and scale appeal while causing no bad effects. No trim correction of any kind is needed when they are used with the recommended throws. The flaps require one channel, a Y-harness, and two standard or mini servos. They are highly recommended for those who wish to install them. More information on the use of the flaps may be found in the flying section.

SUGGESTED SUPPLIES AND TOOLS

- 2 oz. Thin CA
- 2 oz. Medium CA
- 2.5 oz. 5-Minute Epoxy
- 2.5 oz. 30-Minute Epoxy
- Hand or Electric Drill
- Drill Bits: 1/16", 3/32", 1/8", 5/32", 3/16", 13/64", 1/4", 5/64" & 17/64"
- Sealing Iron (Top Flite)
- Heat Gun (Top Flite)
- Hobby Saw (X-Acto Razor Saw or Coping Saw)
- X-Acto Knife, #11 Blades
- Pliers
- Screwdrivers
- T-Pins
- Straightedge with measuring scale
- Masking Tape (Required for construction)
- Sandpaper (coarse, medium, fine grit)*
- T-Bar Sanding Block (or similar)
- Waxed Paper
- Lightweight Balsa Filler (such as Hobbico HobbyLite™)
- 1/4-20 Tap, Tap Wrench
- Isopropyl Rubbing Alcohol (70%)
- Dremel Moto Tool or similar (optional)

NOTE: On our workbench, we have four 11" T-Bar sanders, equipped with #50, #80, #150 and #220-grit sandpaper. This setup is all that is required for almost any sanding task. Sanding blocks can be made from balsa for sanding hard to reach spots. We also keep some #320-grit wet-or-dry sandpaper handy for finish sanding before covering.

OTHER ITEMS REQUIRED

Four to six channel radio with 4 to 7 servos.
 Engine (see page 6 and the box side panel)
 Engine Mount (see page 6)
 Propellers (see engine instructions for recommended sizes). Note: The 4-blade prop shown on the front of this manual is specially made for display purposes from two wooden props and is not usable for actual flight.
 Pilot figure (1/7 or 2" scale recommended)
 4" (102mm) P-51 Spinner (CB #5103 (red), #5105 (black), #5106 (white) recommended)
 Fuel Tank (Most 10 to 14 oz. (296cc to 415cc) tanks will fit)
 3-1/4" (83mm) to 4" (102mm) Main Wheels (2) (see page 6)
 1-1/4" (32mm) Tail wheel (see page 6)
 3/16" (4.8mm) Wheel Collars (4 for fixed gear main wheels)
 3/32" (2.4mm) Wheel Collars (2 for tail wheel)
 Top Flite® Super MonoKote® (2 rolls) Aluminum plus Red, White, Black, and Olive Drab shown
 Silicone Fuel Tubing
 Latex Foam Rubber Padding (Hobbico® 1/4" thick foam)
Optional:
 RetractsRobart #605
 Air Control Kit.....Robart #188
 Hinge Points (for flaps)...Robart #309
 Robostruts.....Robart #653 L&R

COMMON ABBREVIATIONS USED IN THIS BOOK AND ON THE PLANS:

deg. = Degrees	Ply = Plywood
Elev = Elevator	Stab = Stabilizer
Fuse = Fuselage	" = Inches
LE = Leading Edge (front)	Rt = Right
LG = Landing Gear	Lt = Left

TYPES OF WOOD

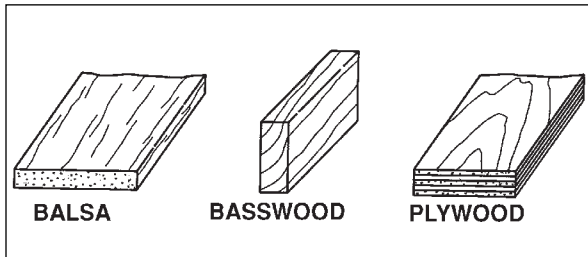

TIPS FOR COMPETITION-MINDED MODELERS

SCALE DOCUMENTATION

This model was designed using the Koko-Fan 3-view drawings as the reference for outline. This fact makes it preferable to use those drawing for scale documentation. The drawings and many Mustang photo packs are available from:

Scale Model Research
 3114 Yukon Ave.
 Costa Mesa, CA 92626
 (714) 979-8058

COUNTERBALANCES

The elevator and rudder counterbalances may be added for scale appearance. They do not affect the flight performance. Their locations and sizes are dashed in on the plans.

SCALE RETRACTS AND DOORS

The retract landing gear pivot location shown on the plans is basically correct. The stance of the model (and strut length) shown with the gear down is correct. Keep in mind that the Mustang's gear, like that in most modern aircraft, compresses under the weight of the aircraft and extends when the aircraft takes off. This fact means that the rigid struts commonly used on models will not fold into the scale locations. The only reasonable way to overcome this problem is to use oleo struts (such as Robart Robostruts) that have springs light enough to compress under the weight of the model and thus function in a scale fashion.

If you should choose to modify your kit to include very scale retracts and doors, most of the work is up to you. Fully cycling gear doors require much preplanning, excellent craftsmanship, and are generally expensive. We can, however, offer a few hints:

1. Bob Violett Models' T-33 main landing gear retracts may be a good place to start for the following reasons.

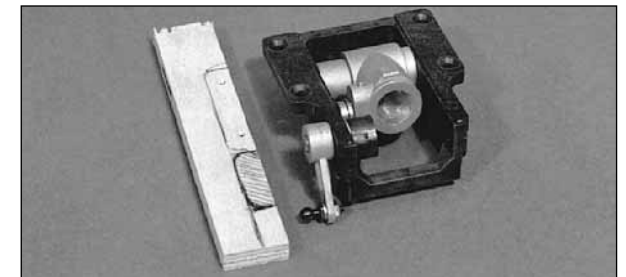

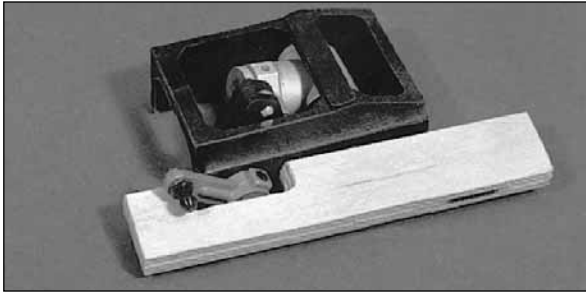

"Photos of Violett T-33 main landing gear and suggested 1/4" plywood aft mounting rail."

- a. They are very low profile and can be buried in the wing deeply enough to leave room for outer doors.
- b. They lock down in a position that is angled. Therefore, they compensate for some of the dihedral in the P-51 wing.
- c. They have a pivot block strut hole diameter that directly accepts Robostruts when shimmed with a piece of K&S brass 13/32" O.D. tubing.
- d. They do not have an uplock and therefore can pull the strut and tire farther than 90 degrees and **fully** into the wheel wells.
- e. Use 5/8" I.D. Robart air cylinders mounted inboard of the retracts to actuate these units. These cylinders have enough power to lift and hold the long strut and heavy tire.

REMEMBER: A retract and strut like this is a very rigid unit. This gives excellent ground handling, but requires **strong mounts**.

2. 4-inch wheels are the closest to scale. However, offset struts to hold 4" wheels may be hard to find. Robart makes an offset strut to hold their 3-1/4" wheel, which works well and looks close to scale. Robart may offer struts for 4" wheels at some time after this writing.

3. Bob Violett Models has **offset door hinges** that are excellent for hinging inner main landing gear doors. They also offer small scale-looking air cylinders that are specifically designed for actuating landing gear doors. The real Mustang's inner doors are closed during take off and landing. When "gear-up" is selected, they open, allow the wheels to come in, then close again. Duplicating this action requires either 2-channels, or a very tricky mechanism. The inner doors on the real aircraft would often fall open when the engine was off and hydraulic pressure was lost.

4. The holes for the forward wing mounts may be drilled so the 1/4-20 nylon bolts are concealed under the inner doors.

GET READY TO BUILD

- 1. Unroll the plan sheets. Re-roll the plans inside out to make them lie flat.
- 2. Remove all parts from the box. As you do, figure out the name of each part by comparing it with the plans and the parts list. Using a felt tip or ball point pen, write the part **name** or **size** on each piece to avoid confusion later. Use the die-cut patterns shown on pages 4 and 5 to identify the die-cut parts and mark them **before** punching out. Save all scraps. If any of the die-cut parts are difficult to punch out, do not force them! Instead, first cut around the parts with an X-acto knife. After punching out the die-cut parts, use your T-Bar or sanding block to **lightly** sand the edges to remove any die-cutting irregularities.
- 3. As you identify and mark the parts, separate them into groups, such as **fuse** (fuselage), **wing**, **fin** and **stab** (stabilizer), and **hardware**.

BUILD THE TAIL SURFACES

- 1. Work on a flat surface over the plans covered with waxed paper. Refer to the plans to identify the parts and their locations.

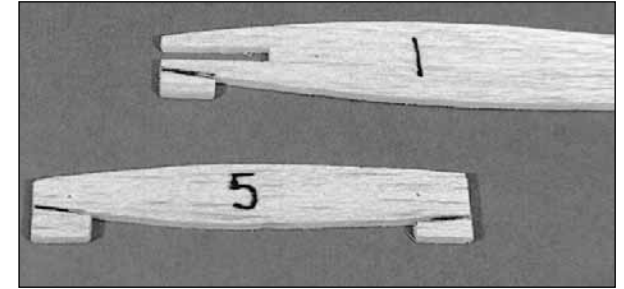

- 2. Punch out both sets of the die-cut 3/32" balsa ribs **S-1** to **S-6**. There are jig tabs on the bottom edges of these ribs. If any of these break off, carefully glue them back on with thin CA. Lightly sand any imperfections. You may need to finish cutting the **notch** in the forward portion of **S-1** for the **Stab Joiner (SJ)** with a knife. Using a pen, mark the extensions of the bottom edge of the ribs across the fore and aft jig tabs. These will aid in centering the Leading and Trailing Edges.
- 3. The **Stab Trailing Edges (TE's)** are die-cut from 1/4" balsa. Since some crushing may happen when die-cutting wood of this thickness, they are supplied slightly long and can be trimmed. Smooth the edges of these pieces with sandpaper.
- 4. The stab and fin **Leading Edges (LE's)** are made from the 1/4" x 30" tapered balsa stock. Cut two pieces about 1/4" longer than the length shown on the plans for the stab LE.

- 5. Starting with the right half of the stab, pin ribs **S-2** and **S-6** to the building board over their locations on the plans.

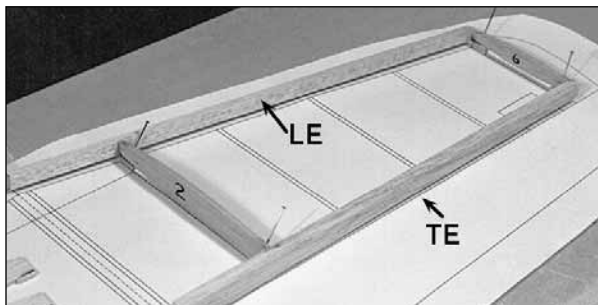

- 6. Center the **LE** vertically on the front edge of ribs **S-2** and **S-6**. Glue it in place with CA.

- 7. Center the **TE** vertically on the back edge of ribs **S-2** and **S-6**. Glue it in place with CA.

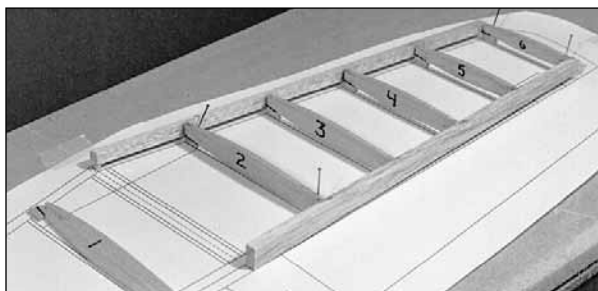

- 8. Glue ribs **S-3**, **S-4**, and **S-5** in their places. All the jig tabs should rest on the work surface.

- 9. Trim the **LE** and **TE** so they end exactly over the stab centerline.

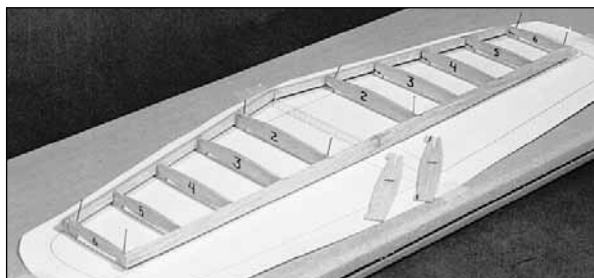

- 10. Repeat steps 5 through 8 to build the left half of the stab. The left half of the stab is built next to the right half with the two halves butt glued together for now.

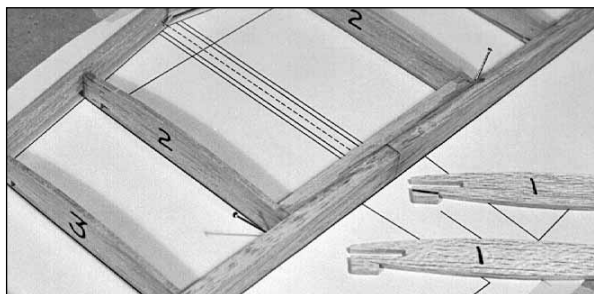

- 11. Trim the 1/4" x 7/16" x 4-1/4" hard balsa stab TE joiner, if necessary, to fit between the **S-2**'s. Securely glue it to the **TE**'s and the **S-2**'s.

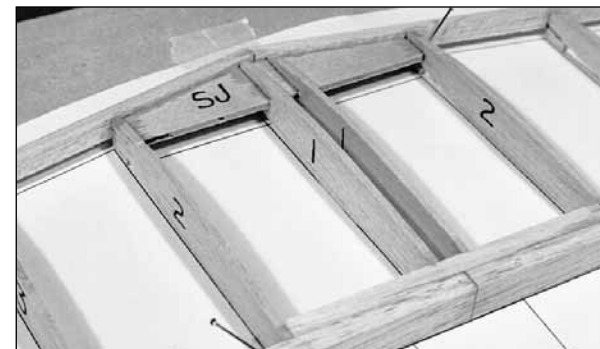

- 12. Trim the length of the die-cut 1/8" plywood **Stab Joiner (SJ)**, if required, for a good fit between the **S-2**'s. Place the stab joiner into the slots in the **S-1**'s and work the whole assembly into position. Make sure all parts are properly aligned and the **S-1** jig tabs contact the work surface. Glue in the stab joiner and the **S-1**'s.

- 13. Using medium CA, reinforce any glue joints that do not look strong.

- 14. Carefully remove the stab from the building board but try not to damage the jig tabs, as they will be useful until after the top of the stab is sheeted.

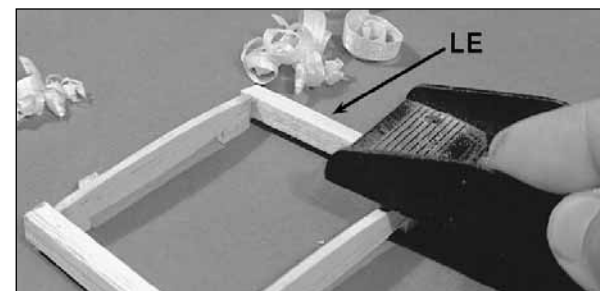

- 15. Use a razor plane and a sanding block to

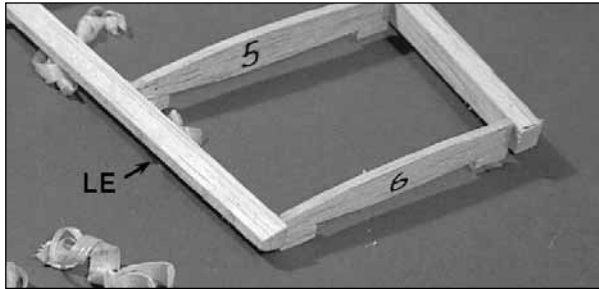

blend the top surface to the LE (particularly toward the tip), even with the ribs. Sand the TE, if required, to blend with the ribs.

TIPS FOR MAKING WING AND STAB SKINS

A. Whenever possible, pre-join the balsa sheets to make a "skin" before attaching them to the structure.

B. Many modelers like to sort the wood to put the best wood with the most even grain structure on the top of the wing and stab.

C. Make your skin larger than needed to allow for misalignment. On a large surface like the wing, 3/8" extra is suggested.

D. To make skins the following steps are suggested:

1. True up the edges of the sheets with a metal straight edge and a sharp knife or a "T-Bar" sanding block.

2. Test fit the sheets together to make sure they match well.

3. Glue the sheets together with thin CA over a flat surface covered with waxed paper. I quickly

wipe the joint with a fresh paper towel to remove excess glue and make sanding easier. Mark the poorest surface that you think should be the inside of the sheet with an "I".

4. Working on a flat surface, sand the skin with a large flat sanding block and **fresh, sharp 220-grit sandpaper**.

5. Trim the perimeter of the sheet to even up the edges.

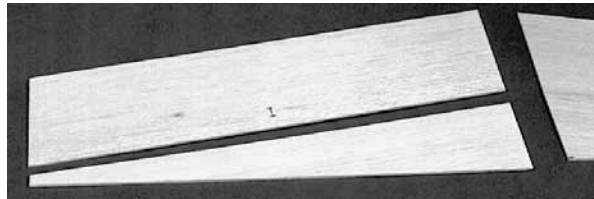

MAKE TWO SHEETS USING THIS TOP PATTERN

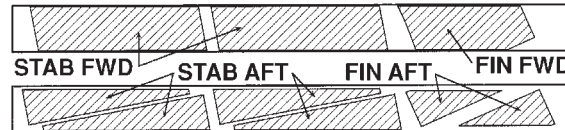

MAKE ONE SHEET USING THIS BOTTOM PATTERN

□ 16. Make four stab skins from three 1/16" x 3" x 30" balsa wing sheet pieces. See the sketch for the proper layout on the wood. Refer to the plans for the exact shapes and sizes, but remember to make the skins slightly oversize.

□ 17. Pin the stab structure onto the flat building surface. Test fit the two skins over the structure. Make sure the skins meet well at the center. Adjust them if necessary.

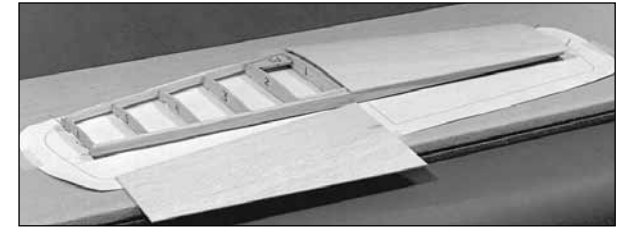

□ 18. Apply an even bead of medium or thick CA to the top edges of the structure. Place the skin in its proper position and press it firmly down until the glue has set. Repeat this step for the other top skin.

Hint: A small stack of magazines can be used to hold the sheeting down.

□ 19. Remove the stab from the building board. Trim off the jig tabs with a sharp knife. Trim and blend the **LE** and **TE** to the ribs as you did before. Check all glue joints, adding glue as necessary.

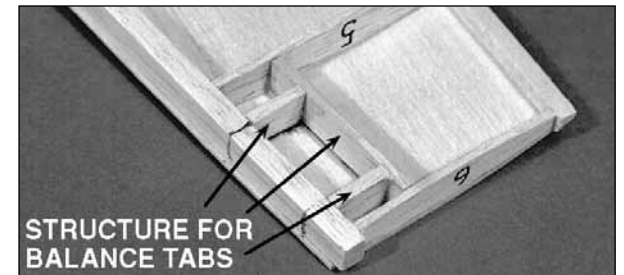

□ 20. If you want to modify the stab for the scale balance tabs or a different hinging technique, now is the time to add the appropriate structure. Refer to the plans for the locations and sizes of the balance tabs (parts not included).

□ 21. It is important to get a good glue bond between the stab structure and the bottom stab skins. Apply a heavy bead of medium or thick CA to all of the bottom edges of the right side of the stab structure. Place a skin on the structure and hold it in place with your hands until the glue sets. Repeat this for the left side. Be careful not to bend or twist the stab during this step.

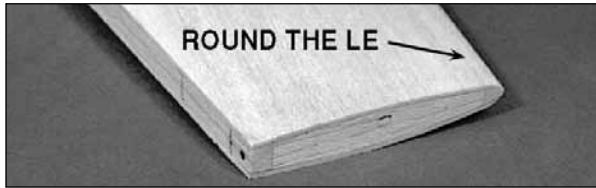

□ 22. True up the ends of the stab with a sanding block. Round the leading edge of the stab to match the cross section on the plan.



□ 23. Glue on the shaped 5/8" balsa **Stab Tips**.

Use a razor plane and a sanding block to shape them to match the stab airfoil. You may contour the tip to its final shape now, or wait until the model is nearer completion.

BUILD THE FIN

□ 1. Cut a 9-1/2" length of the tapered 1/4" balsa stabilizer **LE** stock left over from the stab.

□ 2. Glue the die-cut 1/4" balsa **Fin Forward and Aft TE's (FF and FA)** together with CA. Since these pieces are thick and die-cut, they will probably require a little touch up and blending with a sanding block.

□ 3. Punch out the die-cut 3/32" balsa ribs **V-1** through **V-6**. Be sure to preserve their jig tabs.

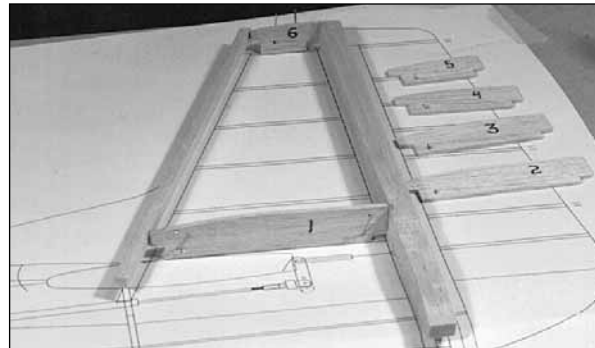

□ 4. Pin ribs **V-1** and **V-6** to the building board over their proper locations. Center the **LE** on the front of the ribs and glue it in place. Notice that the fin LE protrudes through the stab into former **F-11**.

□ 5. Center the Fin TE on the aft edge of the ribs and glue it in place.

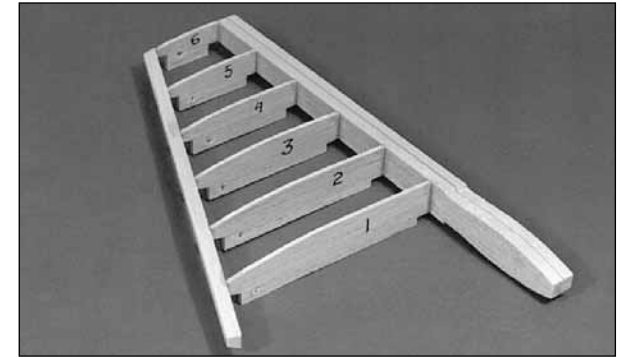

□ 6. Put ribs **V-2** through **V-5** into their places and glue them. Remember, all jig tabs should contact the work surface.

□ 7. Apply extra medium CA glue to any joints that do not appear to be well glued.

□ 8. Blend the LE to match the ribs on the upward facing (left) fin side. Sand the TE if necessary to blend smoothly with the ribs.

□ 9. Make a skin for each side of the fin using the 1/16" balsa sheet left over from the stab skins. See the sketch on page 10.

□ 10. With the structure flat on the table, glue on the left skin.

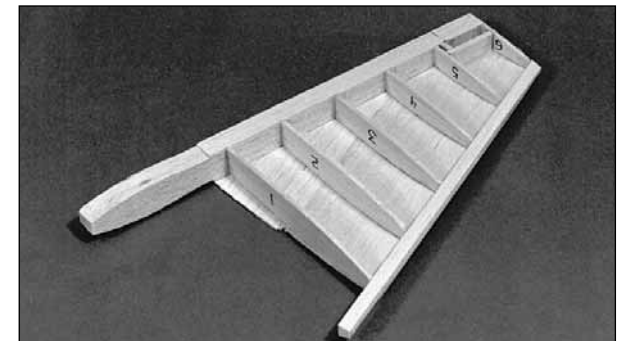

□ 11. Trim off the jig tabs and blend the LE and TE to the ribs on the right side of the fin.

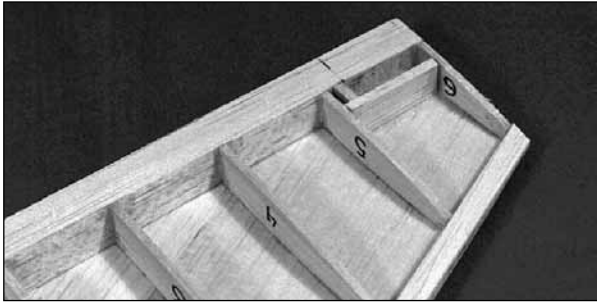

12. If you are adding scale balance tabs, add the simple additional structure as shown in the photo. (Parts not included).

13. Glue on the right skin.

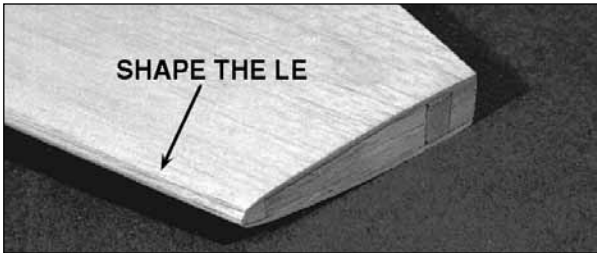

14. True up the edges of the fin sheeting with a sanding block. Shape the LE to match the cross section on the plans.

15. Glue the shaped 3/4" balsa fin tip to the top of the fin. Use a razor plane and a sanding block to do the initial shaping of the tip. Final shaping should be done later, with the fin taped to the rudder.

BUILD THE RUDDER

1. Glue the two die-cut 1/4" balsa **Rudder LE's** together with medium CA. Even up the edges with a sanding block, but save any tapering for later.

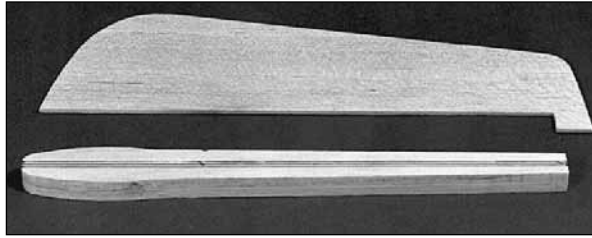

2. Draw a centerline on the aft surface of the LE. Draw two parallel lines 1/16" away from both sides of the centerline.

3. Align the die-cut 3/32" balsa **Rudder Plate (RP)** over the plans and mark the "Rib" locations on both sides of the rudder plate. (See the photo below.)

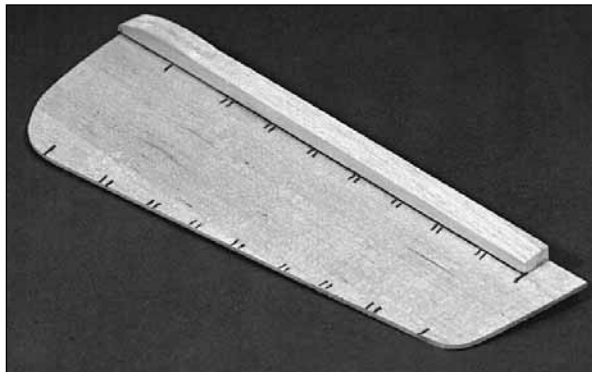

4. Hold the Rudder Plate centered on the rudder LE. Apply thin CA to the joint.

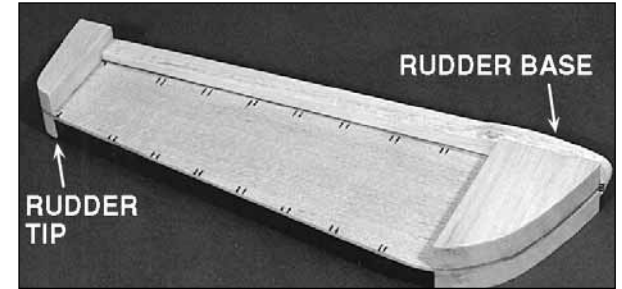

5. Glue the two 1/2" thick shaped balsa **Rudder Tips** to both sides of the top of the rudder plate.

6. Glue the two 1/2" thick shaped balsa **Rudder Bases** to both sides of the bottom of the rudder plate.

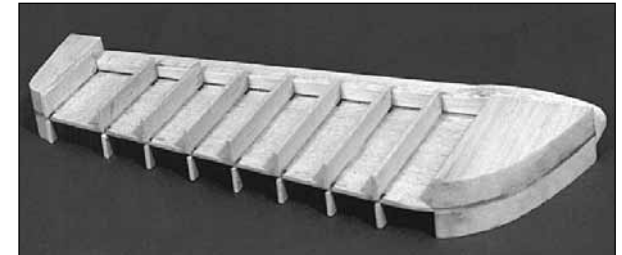

7. Cut "ribs" from the 3/32" x 1/2" x 30" balsa sticks and glue them onto both sides of the rudder at the locations you previously marked.

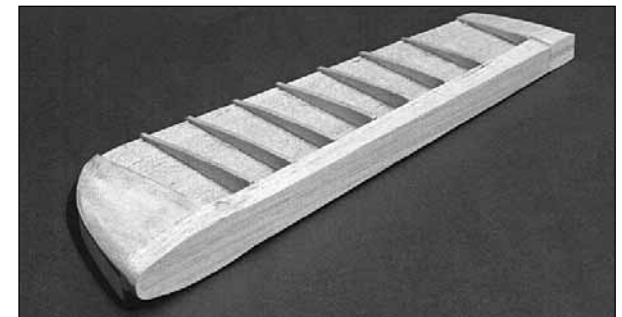

8. Refer to the photos and the cross sections

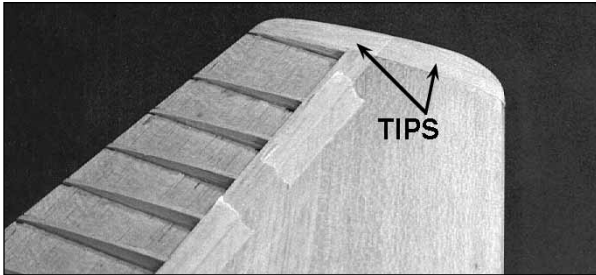
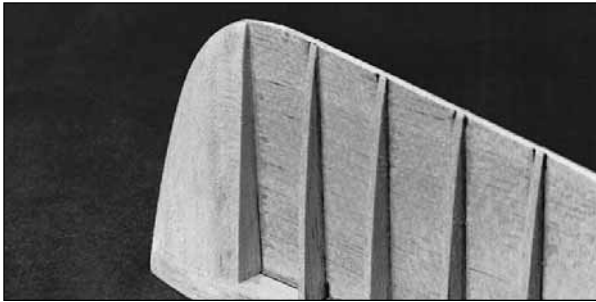

on the plans to obtain the shape of the rudder. Use a razor plane and sanding block to "rough in" the shape of the rudder. Final shaping and fitting should be done after the fin is glued onto the fuselage, but you may wish to tape the rudder to the fin at this point to blend the tips of both.

BUILD THE WING

NOTE: The wings are built "UPSIDE-DOWN" on the plans. The jig tabs are attached to what is, in the end, the TOP surface of the wing.

VERY IMPORTANT! Since it is the standard convention to show the Top View of the wing, and the wing panels are built upside-down, the LEFT wing panel is built over the RIGHT Wing Top View and vice-versa. This does not present any problems. Just be sure to build a left and a right wing.

1. Place the wing plan on your building board and cover it with waxed paper (you may wish to cut the wing panel sections of the plan apart to make handling easier.)
2. Hold the 1/4" x 3/8" x 36" balsa **Spars** over the wing plans. Mark the Spars about 1/4" longer than they need to be. Cut off the spars at the marks and save the excess for the **Flap Servo Mounts**.
3. Punch out all the die-cut 3/32" balsa wing **Ribs**. Smooth out any imperfections with sandpaper. Be sure to keep the jig tabs attached to the ribs.
4. Ribs **W-1** through **W-8** have punch marks just aft of the spar that locate the aileron pushrods for you. Drill a 3/16" hole at each of these marks.

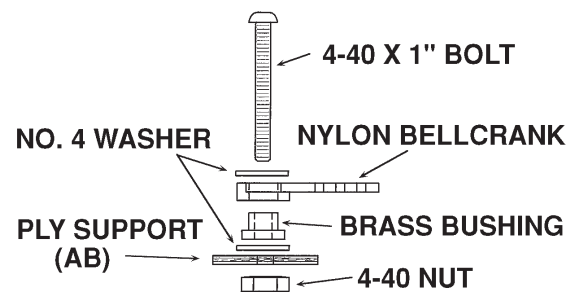
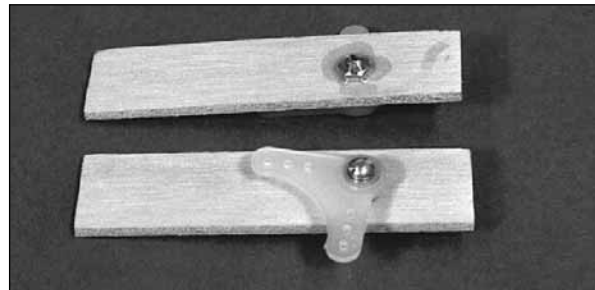

5. Drill 1/8" holes through the punch marks in

the two die-cut 1/8" plywood **Aileron Bellcrank Plates (AB)**. Assemble the bellcrank parts as shown in the sketch, making a left and a right plate. **Be sure to put a drop of 5-minute epoxy on the 4-40 nut and threads to prevent the bellcrank from vibrating loose.**

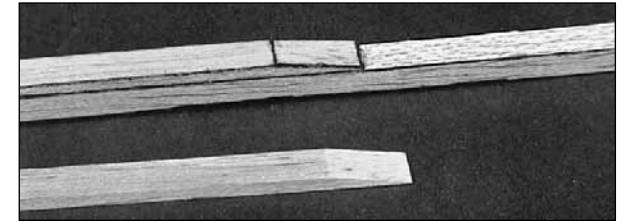

6. Taper one end of each of the four 1/8" x 3/8" x 18" balsa **Spar Doublers** to match the spar detail drawing on the plans. Glue a Spar Doubler to each Spar with the root (non-tapered) end of the doubler aligned with the root end of the Spar.

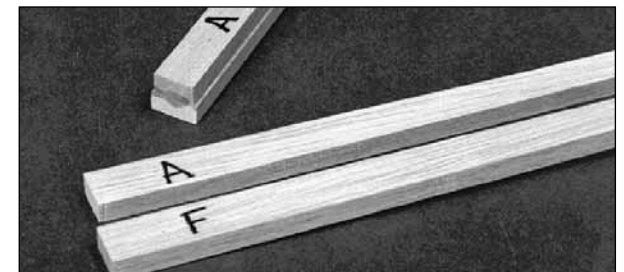

7. Center the die-cut 3/16" balsa **Aft Aileron Trailing Edge (A)** on the die-cut 3/16" balsa **Forward Aileron Trailing Edge (F)** and glue them together with thin CA. Use a sanding block to taper the two pieces slightly as shown in the cross sectional drawing on the plan. These pieces are die-cut slightly long to allow you to trim off any imperfections.

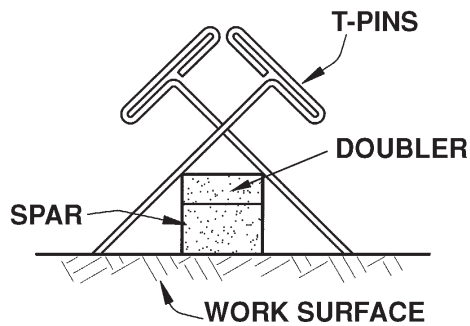

□ □ 8. Pin a **Spar** assembly to the building board at three or four locations using the cross-pinning technique shown in the sketch with the Doublers up.

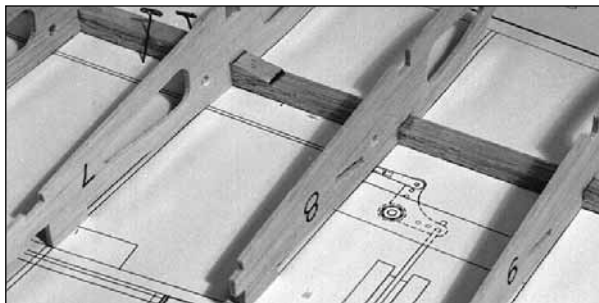

□ □ 9. Glue the die-cut $\frac{3}{32}$ " balsa ribs **W-2** through **W-12** to the Spar. These should be vertical and aligned over their appropriate locations as indicated on the plans. The jig tabs located near the aft end of the ribs should all contact the work surface.

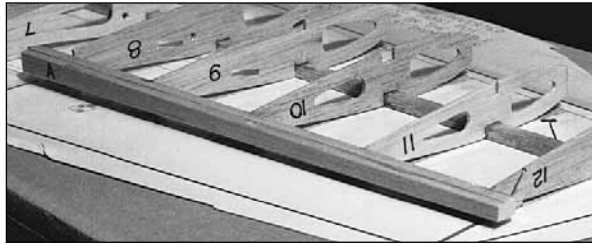

□ □ 10. Glue the aileron **Trailing Edge** assembly to the aft edge of ribs W-8 through W-12. The upward facing edges of the ribs and the Trailing Edges should be even and the jig tabs should all be touching the work surface during this step.

NOTE: The inboard end of the aileron TE extends approximately $\frac{15}{16}$ " inboard of rib W-8, as shown on the plan.

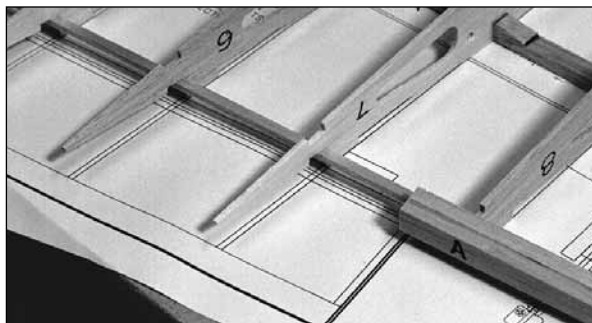

□ □ 11. Glue the lower $\frac{1}{8}$ " x $\frac{3}{16}$ " x 21" balsa TE Spar as far forward as possible in the slots in ribs W-2 through W-8.

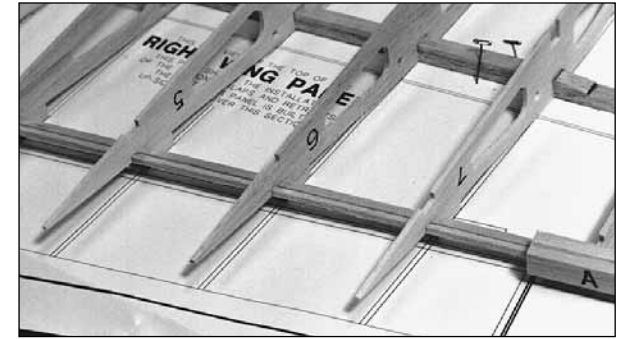

□ □ 12. Glue the lower $\frac{1}{8}$ " x $\frac{1}{8}$ " x 21" balsa **Flap LE** into the **aft** portion of the slots in ribs W-2 to W-7. There should be a $\frac{1}{16}$ " gap between the TE spar and the flap LE.



□ □ 13. Repeat steps 11 and 12 for the slot in the **upper** side of the ribs.



□ □ 14. Glue the $\frac{1}{2}$ " x 21" tapered balsa

Flap TE to ribs W-2 and W-7. The **flap TE** should be centered on the aft edges of the ribs and should protrude straight back (see the cross-sections on the wing plan). Make sure all the jig tabs are contacting the table. A metal straight edge can be placed on the structure over the jig tabs to hold them all down.

□ □ 15. Sight down the TE of the wing from the root end, making sure all the ribs are aligned at the same height. Use paper to shim under any low jig tabs. Glue the Flap TE to the remainder of the ribs.

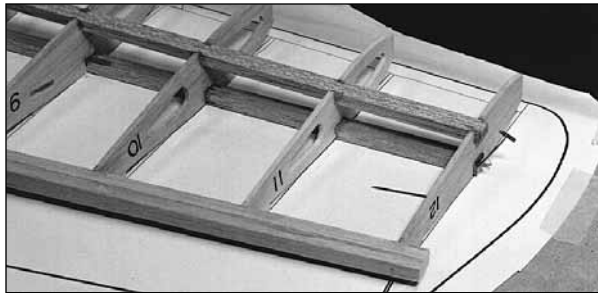

□ □ 16. Work the upper **spar** assembly into place. Make sure it fits well. Put some weights on top of the structure to make sure it is firmly on the work surface. Use CA to glue in the top spar.

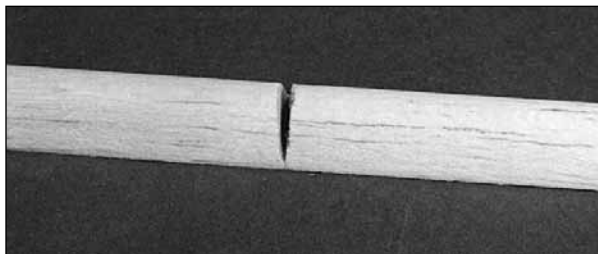

□ □ 17. Use a razor saw to put a V-notch in the

shaped balsa **Leading Edge** to allow it to “bend” (break) at R-4. Use the LE detail drawing on the wing plan for reference.

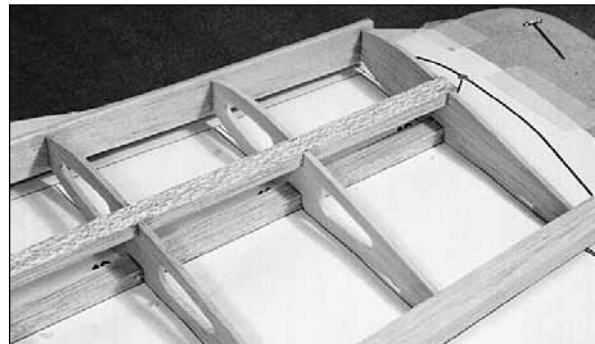
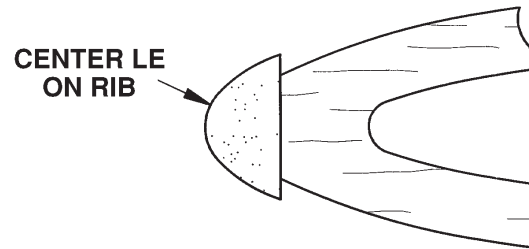

□ □ 18. Hold the LE centered vertically on the front edge of the ribs. Use CA to glue it in place.



□ □ 19. Use thick CA to glue in the die-cut 1/8"

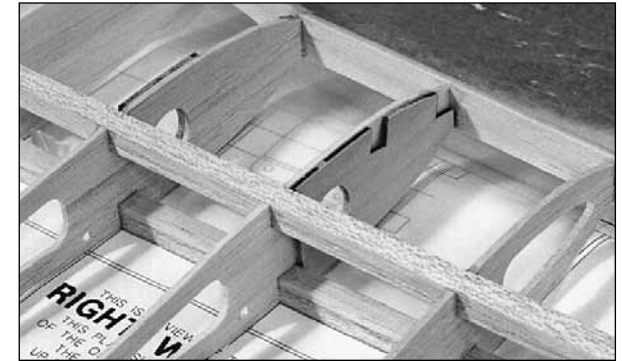

plywood **Landing Gear Doublers**. Since the wing panels are built upside-down, the “openings” in the doublers should face **upwards** as shown in the photos. The right side wing plan shows the placement of the two doublers for **retract gear (Z-4 and Z-5)**. The left side wing plan shows the placement of the three **fixed gear doublers (G-3, G-4, and G-5)**.

Retract Doublers shown



□ □ 20. Use a sharp knife to trim the balsa ribs to match the cut-outs in the doublers.

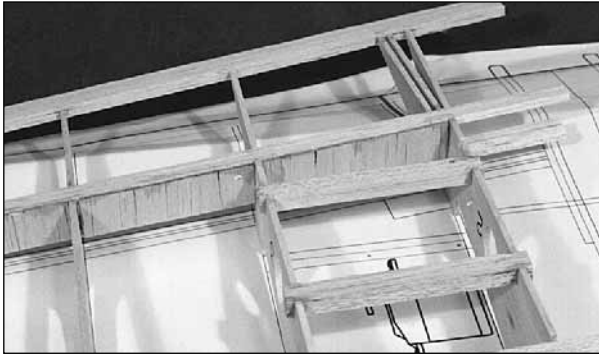

□ □ 21. If you are going to use flaps, trim the 1/4" x 3/8" balsa stock left over from the wing Spars to the length shown on the plans for the flap servo bay rails. Glue the rails into the notches in W-2 and W-3 with CA. If you do not plan to use flaps, you may fill the notches with scrap wood or put the rails in anyway.

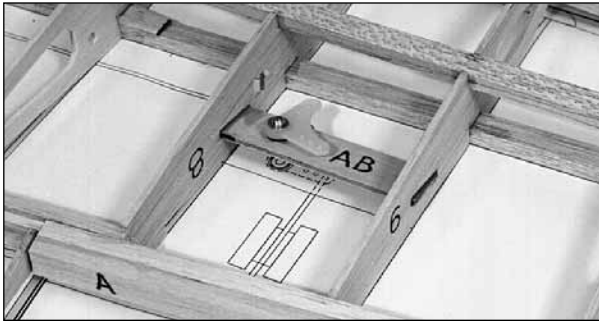

□ □ 22. Glue the aileron bellcrank assembly into the slots in ribs W-8 and W-9. The bellcrank should face upwards as shown in the photo.

□ □ 23. Fit, then glue, in the die-cut 3/32" balsa **Flap Tip Rib** at the location shown on the plans.



□ □ 24. If you plan to use flaps, fit and glue in the two die-cut 3/32" balsa **Flap Root Ribs**. Use a scrap piece of 1/16" balsa to space the root ribs apart. If you are not using flaps, these parts may be glued in anyway, or discarded.

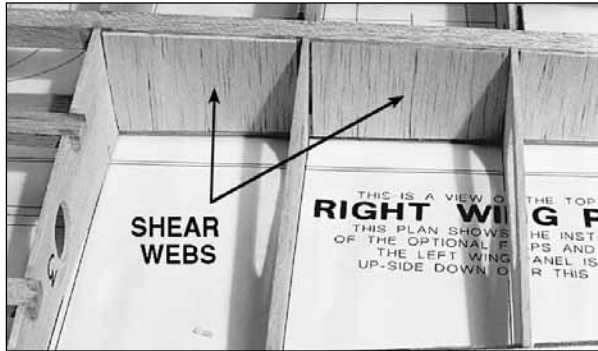

□ □ 25. Custom fit 1/16" balsa **Shear Webs** to fit behind the spar between ribs W-3 to W-12. Glue them to the spars with medium CA. Wick thin CA into all the joints of the shear webs and the spars to make sure they are well bonded. It is not important to glue the shear webs to the ribs.

□ □ 26. Fit and glue a shear web to the **front** of the spars between ribs W-3 and W-4 for extra strength.

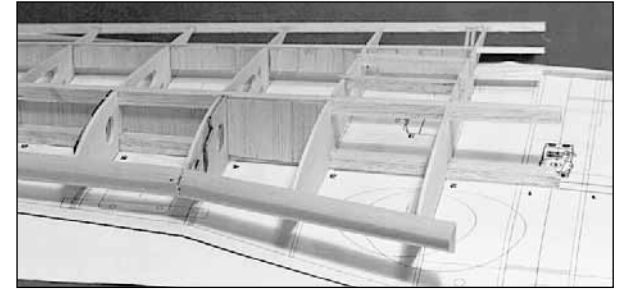

□ □ 27. Sight down the wing trailing edge to make sure it is still straight. Shim any low jig tabs if required. Trim each of the 1/16" x 3" x 3/4" balsa **Aft Shear Webs** to fit between ribs W-2 through W-8 in front of the TE Spar. Glue them in place with the structure held firmly on your flat work surface.

□ □ 28. Cut a 16-1/2" long piece of **Outer Pushrod Tube**. Roughen the outside of the tube with 220-grit sandpaper. Feed the tube through the holes in the ribs as shown on the plans. Use CA to glue the tube to the ribs.

□ □ 29. Cut five lengths of **Inner Pushrod Tube** about 5/16" long. Slide them onto an .074" x 34" **Threaded End Pushrod Wire** at the intervals shown on the plans. Carefully apply a small drop of CA to the short tubes if they are not very snug on the wire.

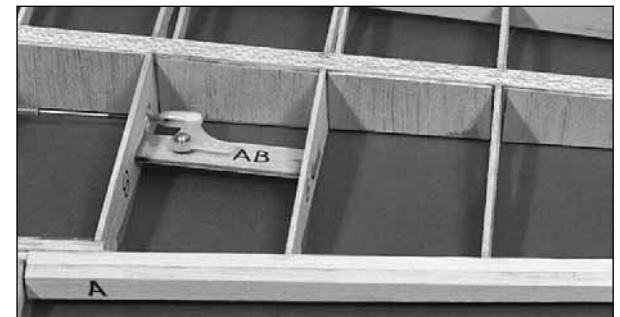

□ □ 30. Enlarge the pushrod hole in W-8 to

allow for free movement of the pushrod and clevis. Securely snap a **nylon clevis** onto the bellcrank. Feed the wire assembly into the wing and screw the threaded end well into the clevis. **Hint:** The wire is extra long. After the threaded end starts threading into the clevis, you may bend over the excess wire and use it as a handle to turn the wire the rest of the way into the clevis. Be sure to hold the clevis securely with pliers while threading the wire into it to keep from stressing the clevis pin. Cut off the excess wire flush with the root end of the spar.

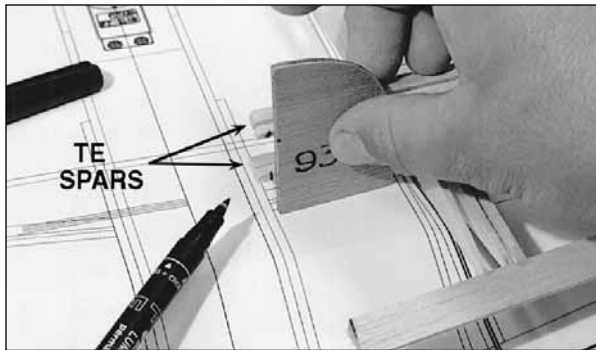
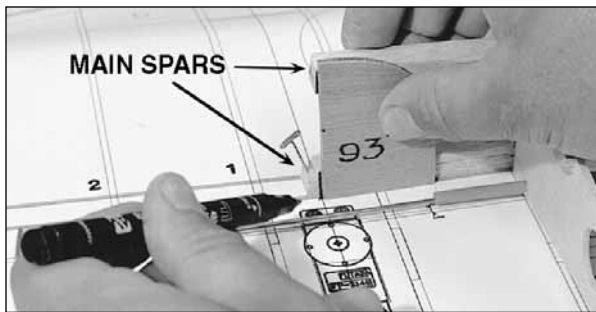

□ □ 31. Use the die-cut plywood **93 deg. tool (93)** as shown to mark the ends of the spars and TE's.

NOTE: When marking the spars, the corner of the tool is on the wing centerline. When marking the TE spars and flap LE's, the corner of the tool is positioned where the TE spars end on the plan.

DO STEPS 32 AND 33 IF YOU ARE BUILDING OPERATING FLAPS.

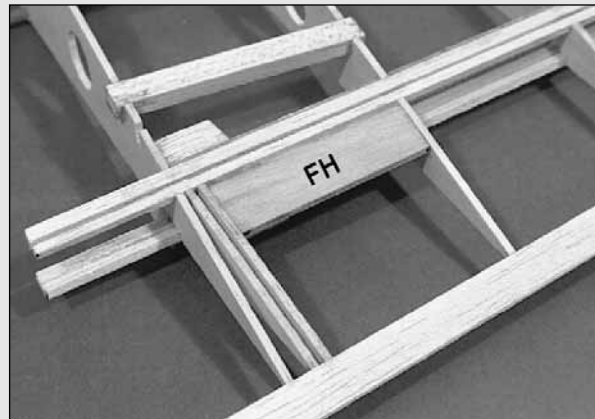

□ □ 32. Glue the die-cut 1/8" plywood **Flap Horn Base (FH)** in its place between W-2 and W-3. Note how it is flush with the upward facing edge of the ribs.

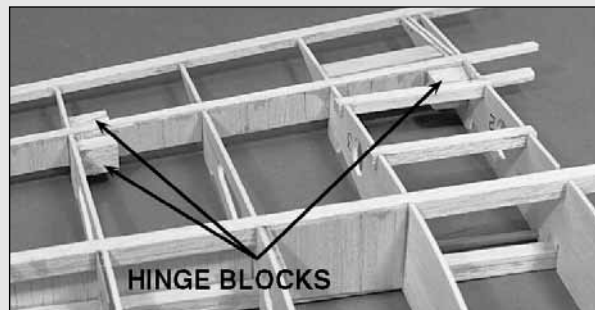

□ □ 33. Cut pieces approximately 1" long from

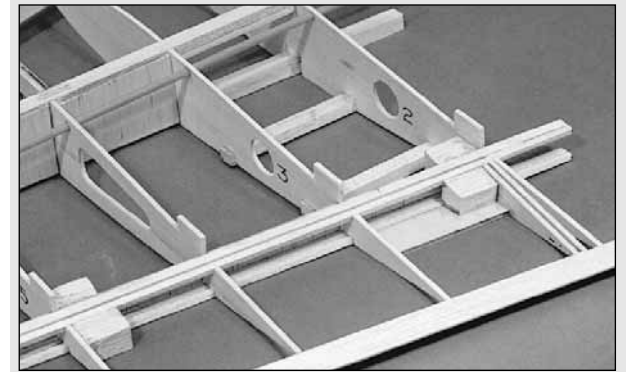

the 1/2" x 3/4" x 12" balsa stick provided to act as **flap hinge blocks**. These are shown on the right wing panel plan. Some custom fitting of these, such as tapering, is required. Skip to step 36.

DO STEPS 34 AND 35 FOR FIXED GEAR.

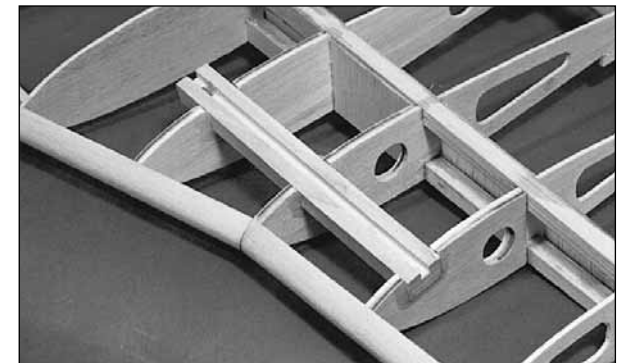

□ □ 34. Glue the 1/2" x 3/4" x 6-3/4" slotted hardwood **Landing Gear Rail** and the 1/2" x 3/4" x 1-1/2" maple **LG Block** with a generous amount of epoxy. Their locations are shown on the left wing panel drawing. Drill a 3/16" hole through the rail and block at the location shown on the plan, to allow the landing gear wire to be inserted.

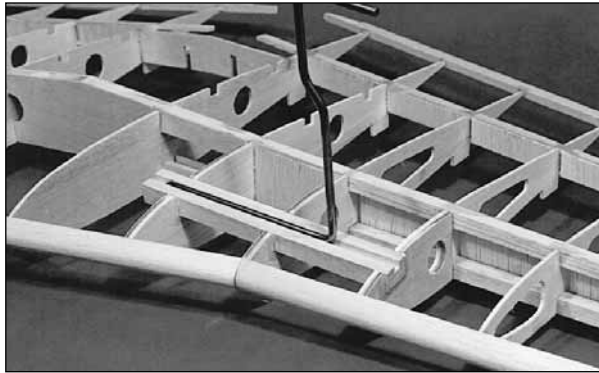

- 35. Make any adjustments necessary to allow the bent wire main landing gear to slide properly into place.

DO STEPS 36 - 39 FOR RETRACT GEAR.

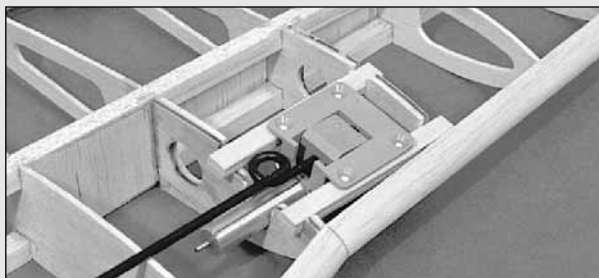
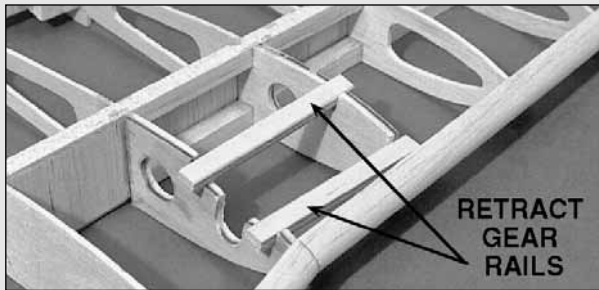

- 36. Slide the 1/4" x 3/8" x 3-3/4" plywood **Retract Gear Rails** into the slots in W-4 and W-5. Test fit your retracts between the rails. If the rail

spacing is not correct (it should be for most retracts) adjust the aft slots.

- 37. Manually extend and retract the gear, noting the strut angle. Adjust the depth of the slots if necessary to give a satisfactory angle when the gear is retracted and extended. It will be necessary to cut a slot in R-3 for the strut to pass through.

- 38. Use generous amounts of 30-minute epoxy to glue in the rails.

- 39. Mark and drill the retract mounting holes in the retract rails.

Repeat steps 7 to 39 to build the other wing panel.

NOTE: *At this point you may remove the wing panels from the building board if you have not already done so. Try to store your panels on a flat surface with some weights on top of them until they are joined and sheeted, to prevent warping.*

JOIN THE WING PANELS

- 1. Trim the ends of the spars, LE's, and TE's of both panels very close to the **tip rib W-12**. Excess overhang will affect the dihedral angle.

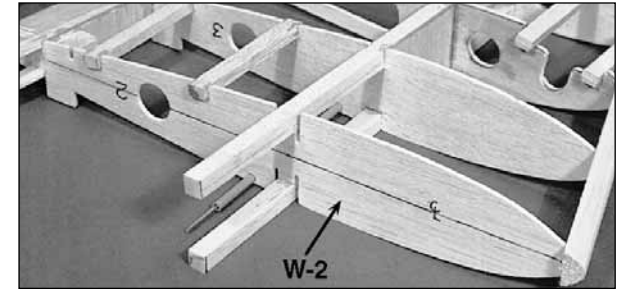

- 2. Draw a centerline on both W-2's as shown in the photos.

- 3. Trim all the spars at the root end of the wing as they were previously marked with the 93 degree tool.

- 4. When you are totally ready to join the wings, trim off all the jig tabs **except** those on **W-2** and **W-12**. Use a small sanding block to "clean up" the area around the tabs.

- 5. Place the two 3/8" x 1-1/2" x 7-1/2" **Dihedral Jig Blocks** under the two W-2 ribs. Place the wing halves together **upside-down**. The spars at W-2 and the W-2 jig tabs on both panels should rest on the Jig Blocks. The tip ends of the spars and the W-12 jig tabs rest on the table (see photo on the next page).



□ 6. Test fit the wing panels on the Jig Blocks with the two die-cut 1/16" plywood **Dihedral Braces** in place. Adjust any parts until the panels join up nicely at the spars. The die-cut 1/8" plywood **Aft Cross Brace (CB)** should be included in these test fittings. If it requires trimming, take equal amounts off the right and left ends.

□ 7. Make two **equal** length sticks from scrap to act as spacers between the two W-2's. These should be positioned on the W-2 centerline. The length of these sticks will vary slightly depending on how your spars are trimmed, but 5-1/2" is a good starting point (see photo below). These two sticks will make sure the W-2 ribs are parallel.

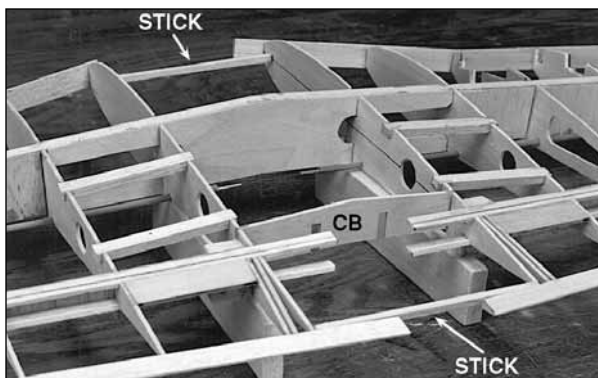

□ 8. Test fit the Aft Cross Brace and the sticks between the two W-2's and adjust both sticks **equally** if adjustment is required. You may notice that the spars sweep forward slightly. This is normal.

□ 9. When the wing fits on the Jig Blocks with the **Aft Cross Brace (CB)** and the two equal length sticks in place, it is time to glue it together. The best method is to use 30-minute epoxy. Coat the mating surfaces of the spars and dihedral braces. Then assemble the parts onto the Jig Blocks. Use CA to **tack** glue the two equal length sticks into place as shown in the photos. Use CA to glue the Aft Cross Brace (CB) into place. Use masking tape to clamp the dihedral braces to the spars.

□ 10. Make four 1/16" balsa shear webs to cap the dihedral braces between W-2 and W-3.

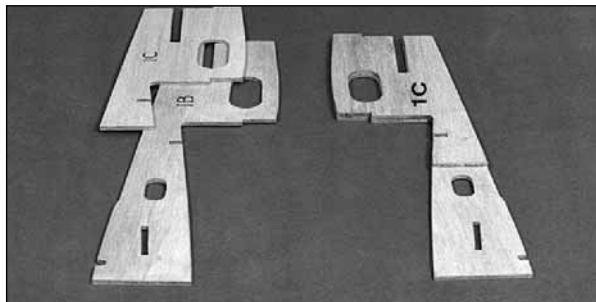

□ 11. Align and glue the die-cut 1/8" plywood **W-1C's** to the die-cut 1/8" plywood **W-1B's**, being sure to make a **left** and a **right**.

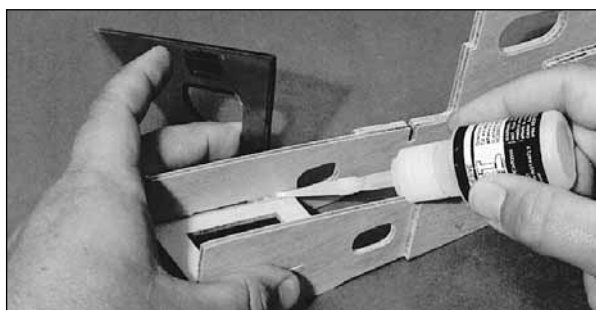

□ 12. Plug the die-cut 1/8" plywood **Aileron Servo Tray** between the two W-1B/C's. Make

sure all the front edges are aligned. Use a 90 deg. triangle to hold each W-1B/C vertical while you glue it to the servo tray.

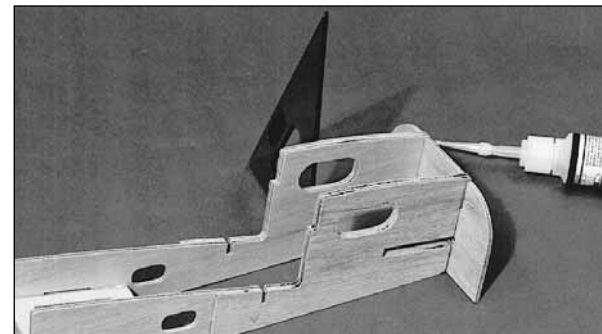

□ 13. Plug the die-cut 1/8" plywood **F-8B** into the aft end of the assembly. Check to see that all edges are square and properly aligned. Use a hobby knife to make small adjustments to the notches if required. Use a 90 deg. triangle to hold the W-1B/C's vertical while you glue them to F-8B.

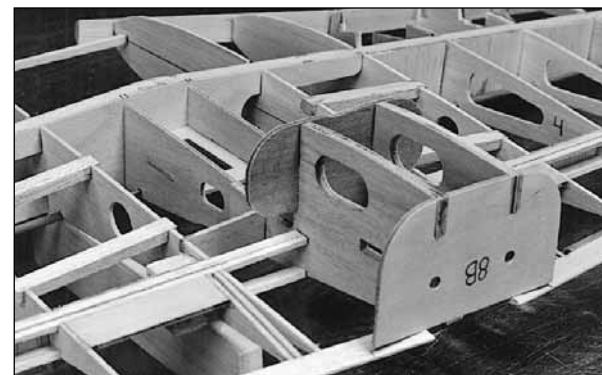

□ 14. Remove the rear stick. Work the assembly into position in the center of the wing. Trim the aft spars and flap LE, if necessary, to fit the assembly. Trim the flap TE as shown on the plans and in the photos to allow clearance for F-8B. The photos with steps 17 and 18 show you the finished assembly.

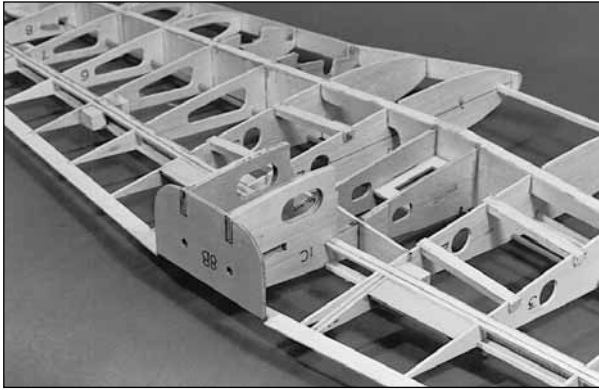

□ 15. Notice that the W-1 ribs in the assembly are undersized 1/16" (except the area around the top of the aileron servo) to allow for a center doubler of 1/16" balsa center sheeting. Put marks on the dihedral braces 3/4" both ways from the center of the wing to aid in the alignment of the center assembly.



□ 16. The front of the assembly is positioned by aligning the top edge of the assembly with the top of the dihedral brace. Tack glue the assembly at the front edge. **NOTE:** The word "top" refers to the top surface of the wing.

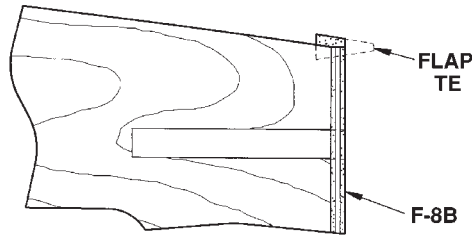

□ 17. The back end of the assembly is aligned by **centering** the flap TE on the top edge of F-8B at W-1. The Aft Cross Brace (CB) should protrude about 1/16" on both sides of the W-1 ribs to allow for the double sheeting.



□ 18. Thoroughly glue all the joints in the area of the center assembly with medium CA.

□ 19. Make shear webs for the aft spar between W-1 and W-2. Glue them to the front of the aft spar with medium CA.

□ 20. Trim the length of the 1/4" plywood beveled edge **Wing Bolt Plate** until it fits between the two W-2's near their centerline.

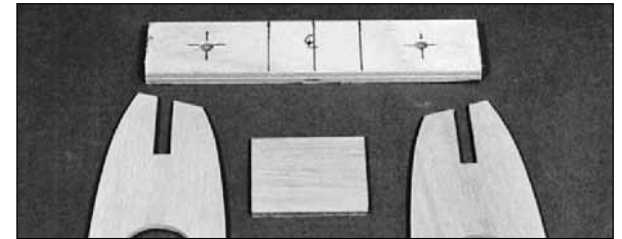

□ 21. Mark a centerline on the Wing Bolt Plate. Mark two lines offset 3/4" on both sides of the centerline as shown.

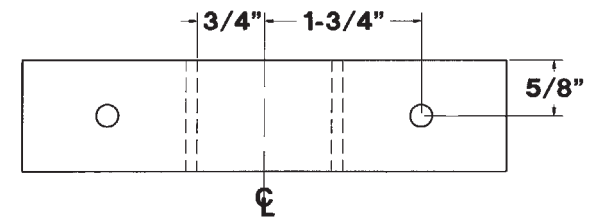

□ 22. Mark the wing bolt hole locations as shown in the sketch above. Drill 13/64" pilot holes at the locations marked.

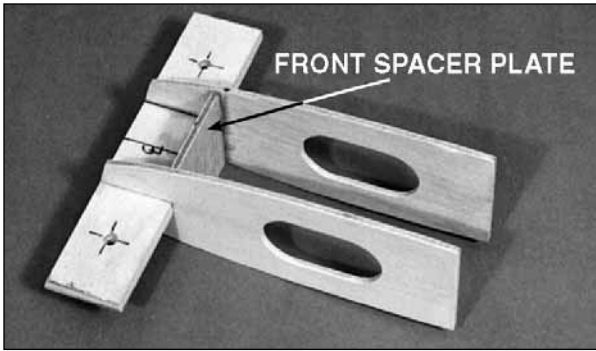
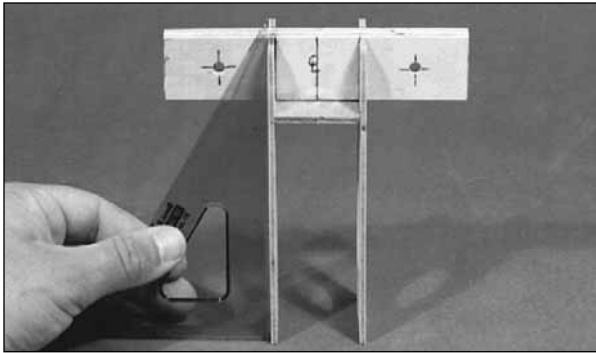

- 23. Assemble the two die-cut 1/8" plywood **W-1A's**, the die-cut 1/8" plywood **Front Spacer Plate**, and the Wing Bolt Plate as shown. Use a 90 deg. triangle to check the alignment. Then glue the assembly together.



- 24. See the cross section at W-1 on the

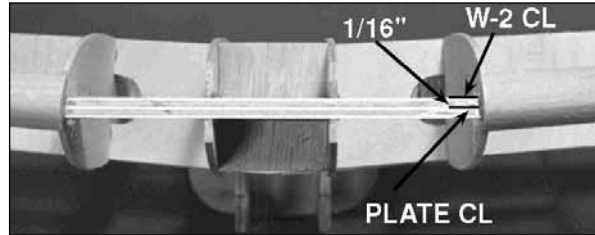

fuselage plan for the proper orientation of the angle on the front of the W-1A's. Fit this forward assembly between the two W-2's. The aft edges are centered on the front face of the dihedral brace (you also may look ahead to the wing sheeting section to see why the W-1 ribs are undersized). The front is located by placing the center of the 1/4" wing bolt plate 1/16" below the centerline on the W-2's (toward the bottom surface of the wing).



- 25. Glue the two die-cut 3/16" balsa **Center Leading Edges (CLE's)** together with CA. Sand their length, if necessary, until they fit between the two wing leading edges in front of the Wing Bolt Plate. Glue in the CLE's. You may rough contour them now, but do the final sanding after the wing has been sheeted.

SHEET THE WING

- 1. Sort through the remaining 1/16" x 3" x 36" wing sheeting. Pick out the best 8 sheets and set them aside for the top of the wing.

- 2. Notice that the center wing rib W-1 is 1/16" undersized everywhere but on top of the aileron servo. This is to allow you to put 1/16" center sheeting over the W-1 ribs to reinforce the center-section.



- 3. Cut 2" long pieces of sheeting from the 1/16" wing sheeting. Glue the sheeting to the top and bottom of the two W-1 ribs (except on top of the aileron servo tray) as shown in the photos.

NOTE: This is a somewhat unique way of joining the sheeting in the center of the wing that eliminates the need for glassing the center section. Do not try to sand the center sheeting so the wing skin will have 100% contact with it. If the skin is left a little high on the top surface of the wing, it is fine, since this part of the wing is hidden under the saddle.



- 4. Block sand the center sheeting slightly, particularly on the bottom, to blend it with the shape of the other wing ribs.

NOTE: The wing sheeting process described here involves making a skin that covers most of the wing first, then gluing it to the structure. This skinning process requires fairly quick and accurate work when you apply the skin to the wing. An alternative is sheeting the wing with individual sheets, which requires less preparation and does not require you to work as fast. It does not allow you to pre-sand the seams. We recommend you read through the entire sheeting section before proceeding. Then use whichever process you are comfortable with.

NOTE: All balsa sheeting will usually bend when it is cut from the log because stresses are relieved. For best results, trim the edges of the wing sheeting with a long metal straight edge and a sharp knife before joining them.

- 5. Lay waxed paper over a flat smooth work surface. You will join the wing skins on this surface.
- 6. Edge glue four 1/16" x 3" x 36" balsa wing sheets together with thin CA for each of the four wing surfaces. **Hint:** A quick wipe of a paper towel while gluing the sheets will soak up most of the excess CA and make sanding the seams easier.
- 7. LIGHTLY sand both sides of the skin over the work surface with a sanding block and sharp 220-sandpaper.

NOTE: The steps below show sheeting the flap with a separate piece of wood. This orients the grain more parallel with the flap span and makes it easier to fit.

NOTE: If you are building functioning flaps, you may choose to cut the flaps loose from the structure before sheeting them. If there are any slight warps in your flap trailing edges, this will allow you to straighten them during sheeting. If your structure appears straight, we think you will find it best to sheet the flaps while they are still attached as shown in the construction sequence.

- 8. Tape a skin to the bottom of the wing structure, aligning it with the leading edge. Mark the outer extents of the wing from the other side of the structure. We usually leave about 3/8" overhang where possible.

- 9. Cut the skin to the shape you marked. Check the fit of the skin to the structure and make adjustments until it fits well (see photo at step 15).
- 10. Trace the shape of the skin onto the other bottom skin. Trace the shape of the skin onto the two top wing skins. It is not an exact match, but this will offer an excellent starting point.
- 11. Make the outer aileron pushrods by putting a Z-bend in two of the **.074 x 12" Threaded End Pushrod Wires** to match the length shown on the wing plan.



- 12. Enlarge the outer hole in the aileron bellcrank with a 5/64" drill bit. Hook the pushrod up to the bellcrank. Make certain the Z-bend can't bind against the bellcrank plates.

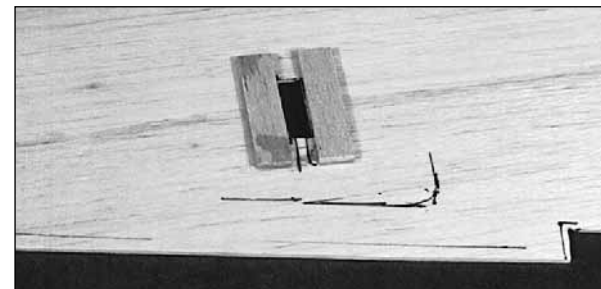

- 13. Make cut-outs to allow the aileron



pushrods to exit the bottom wing skins. The plans show the proper size and location of these holes. Reinforce the inside edges of the slots as shown with strips of scrap balsa.

- 14. Put the wing upside-down on its "jig." You may want to tack glue the wing to the table and jig to keep it from moving around.



- 15. Apply a **generous** bead of slow CA glue to all the structure the skin will contact. Apply the skin to the wing, starting with the leading edge. Use thin CA and kicker to anchor the Leading Edge. Roll the rest of the skin back over the structure and press it in place until the glue sets.

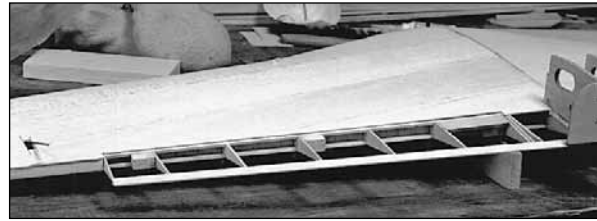

- 16. Apply the other bottom wing skin.
- 17. If you are using functioning flaps, put light marks on the skins where the hinges will go, so you can find the blocks later.

NOTE: If you are building operating flaps, you may leave a small gap in the sheeting along the flap cut line to make it easier to cut the flaps loose later.

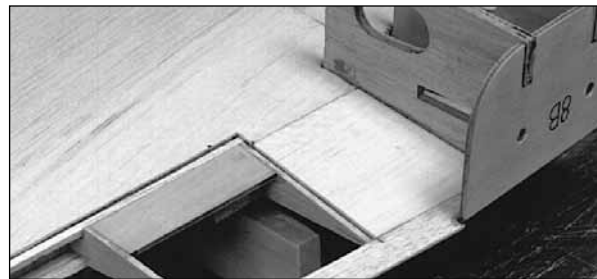

- 18. Sheet in the areas of the bottom of the

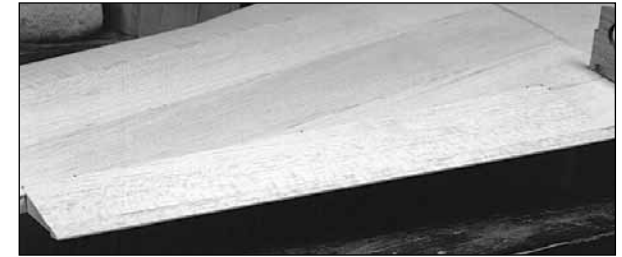

wing that are not covered by the main skin.

NOTE: Leave the wing on the jig until you are ready to sheet the top of the wing. This allows less time for moisture and stress to twist the wing.

- 19. Trim any remaining jig tabs off the ribs and blend any high spots away with a sanding block.
- 20. Pass a 13/64" drill through the Wing Bolt Plate. Then drill through the bottom skin to eliminate any problems finding the holes later.
- 21. Fit the top wing skin to the wing.

NOTE: The top skin may be glued on in one of three ways: You may glue the skin to the wing structure all at once as you did when sheeting the bottom, you may glue on the individual sheets separately, or you may follow the procedure below.

- 22. Tape the wing skin to the LE in a few places. Use thin CA to glue the skin to the leading edge.
- 23. Set the wing horizontally on the table and lift the trailing edge so the wing tilts forward at about 40 deg.

□ 24. Working rapidly, put a stream of medium CA on each rib at the spar and allow it to run forward down the rib to the leading edge. Put a bead of medium CA on the spar.

□ 25. Hold the wing vertically on one wing tip and, starting at the middle, roll the skin back onto the wing. By holding the wing on its tip, and putting equal pressure on both sides of the wing, the wing will retain its proper shape and washout.

□ 26. Now run glue down the aft portion of the ribs and put glue on the trailing edges. Hold the wing vertically on its tip again and press the aft portion of the wing skin onto the structure.

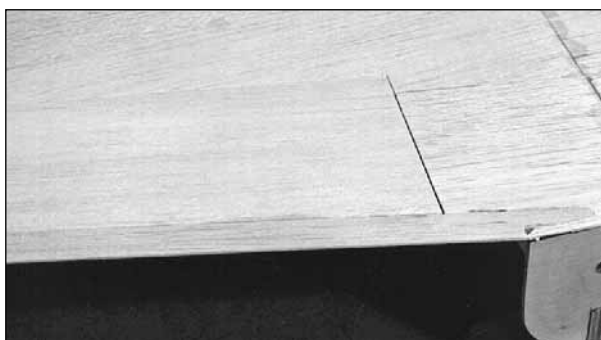
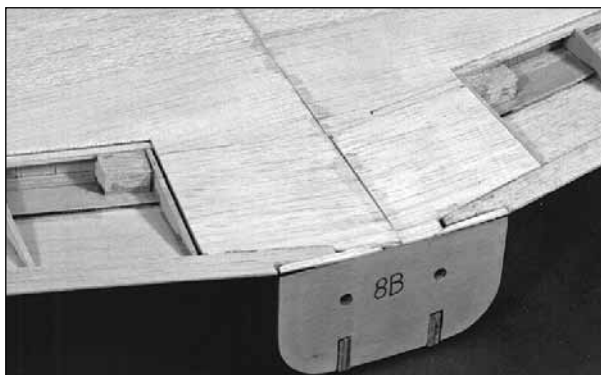

□ 27. Sheet the areas of the top of the wing



that are not covered by the main skins.



□ 28. Cut out and enlarge the holes where the wing bolts pass through the skins to about 1/2".

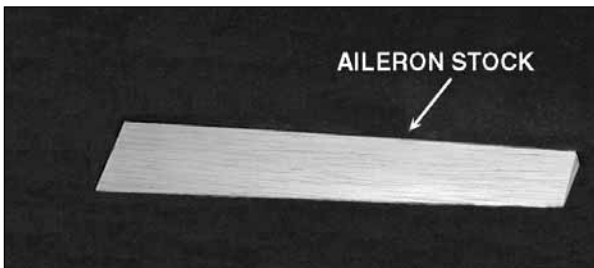

□ 29. Locate the 12-1/2" long double tapered balsa **Ailerons**. The ailerons are very similar to the elevators, but they are longer. Check the

taper of the ailerons over the plans to make sure you have the correct parts.

□ 30. Test fit the aileron to your wing. Trim the aileron front edge and root end for a good fit. The tip end of the aileron should be fitted after the wing tip has been installed.

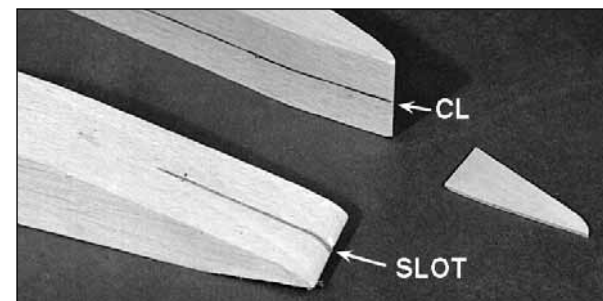

□ 31. Die-cut 1/16" plywood **Wing Tip Braces** are supplied to strengthen the aft end of the wing tip. Saw a 1/16" slot along the centerline of each shaped 1-1/4" balsa **Wing Tip** and glue the braces in with CA as shown.

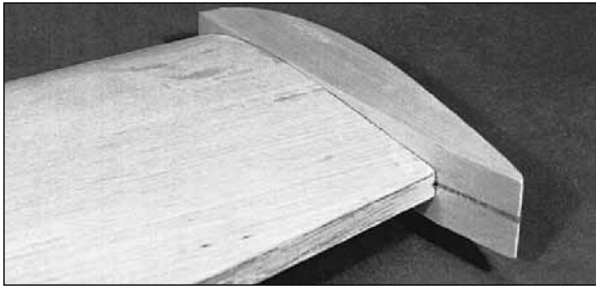

□ 32. Glue the Wing Tips onto the wing, carefully centering the tip brace at the TE. Use a knife, razor plane, and sanding block to shape the wing tips.

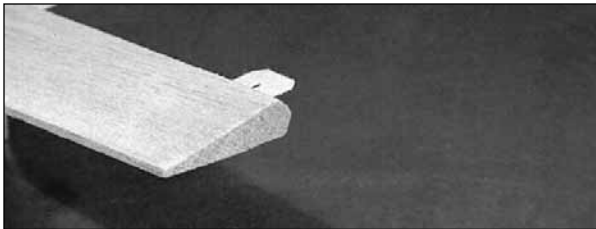

□ 33. Trim the tip of the aileron so it fits properly between the flap and the wing tip. Shape the LE of the aileron to the "V" shape as shown in the photo and on the cross section on the wing plan.

BUILD THE FUSELAGE

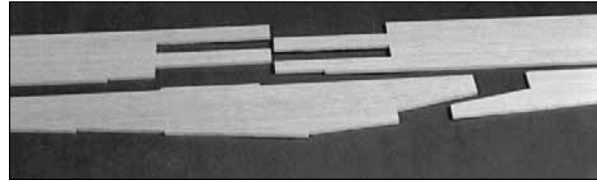

□ 1. Test fit the die-cut 1/8" balsa **Upper Forward Fuse Side, Upper Aft Fuse Side, Lower Forward Fuse Side, and Lower Aft Fuse Side** together. These should be aligned over the Fuselage Side View on the plans, or by placing a long straightedge along the top edge of the upper parts. Adjust any joints that do not fit well.

□ 2. Place waxed paper over your work surface. Reassemble the parts and check their alignment. For a straight fuselage, it is important to have the fuse sides straight, and both the same. Use thin and medium CA to glue the parts together. Use a quick wipe with a paper towel to remove excess glue, as this will make sanding easier. Keep in mind that you are making a left and a right fuselage side.

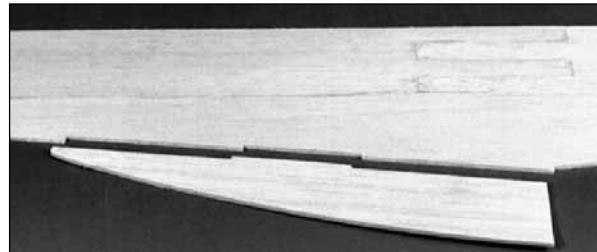

□ 3. Glue the die-cut 1/8" balsa **Radiator Side** to the bottom edge of each fuselage side. Sand the joint with a sanding block and 220-grit sandpaper.

□ 4. Inspect the two fuselage sides. Choose the Right and Left sides so the best surfaces will face outward. Mark the inside of the appropriate part **RI** and **LI** (for **Right Inside** and **Left Inside**.) Sand the outside (and to a lesser extent the inside) of each side with a sanding block and sharp 220-grit sandpaper to smooth out the joints and the surface.



□ 5. Glue a die-cut 1/8" balsa **Aft Fuse Doubler** to the **inside** of each fuselage side (**be sure to make a left and a right**). Align the stab saddle and the top edge of the doubler with the fuse side when gluing.

□ 6. Compare the two die-cut 1/8" **Plywood Fuse Doublers**. Label the shorter one "**R**" (right) and the longer one "**L**" (left). This will set the right thrust in the firewall.

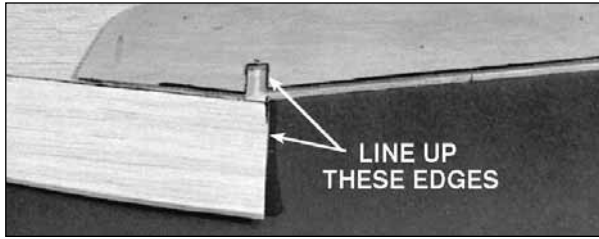

- 7. Line up the fuselage doublers using the notch at their back (for F-8) and the wing saddle as the primary references. Be sure to put them on the inside of the fuselage sides and make a left and a right. Glue the doublers in place with CA.

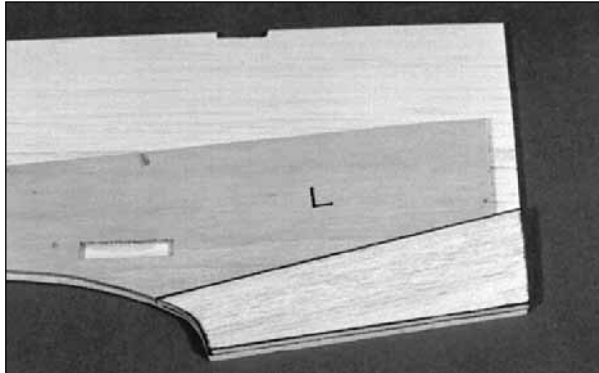

- 8. Glue the die-cut 1/8" balsa **Forward Fuse Doublers** in place. They should touch the Plywood Fuselage Doublers.

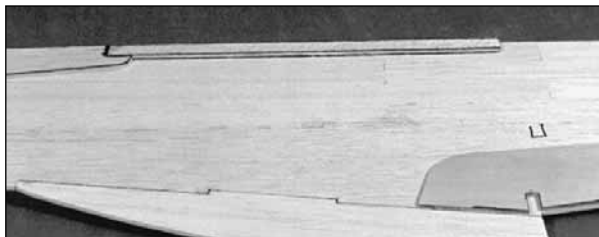

- 9. Glue a 1/8" x 3/8" x 9" balsa **Doubler Stick** along the top edge of each fuselage side beginning at the notch in the aft fuse doubler.

Tape the **Fuselage Bottom View** over your flat building board (we recommend cutting that part of your plan loose to make it easier to handle). Cover the bottom view with waxed paper.

Important Note: You are building the fuselage upside-down over the Bottom View. This aircraft has right thrust built in. Since the fuse is built upside-down, this will appear to be left thrust until it is flipped over. Just follow the instruction sequence and everything will be fine.

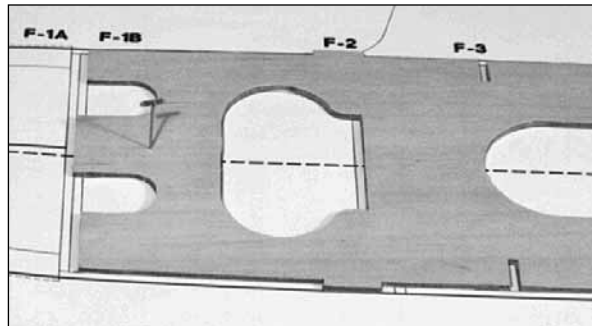
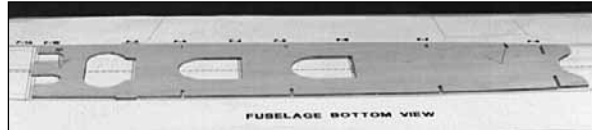

- 10. Pin the die-cut 1/8" plywood **Forward Crutch** over its location on the plans. Make sure the front edge of the crutch matches the plans for the correct thrust angle.

NOTE: Some formers are not symmetrical and must be glued in with the proper orientation. Glue in all the formers with the I.D. numbers toward the **FRONT** of the model and they will all be correct.

- 11. Drill 3/16" holes through the punch marks in formers F-5, F-7, F-8, F-9, F-10, and F-11. These holes are for the pushrod mounting, and you may confirm these locations using the cross-sections on the fuselage plans.

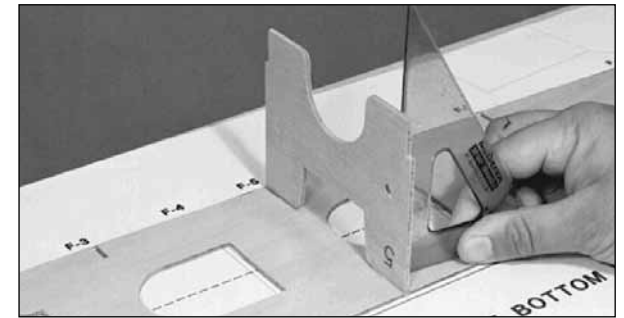

- 12. Glue the die-cut 1/8" plywood former **F-5** to the forward crutch at its location on the plans. It should be perpendicular to the crutch with its number facing forward.

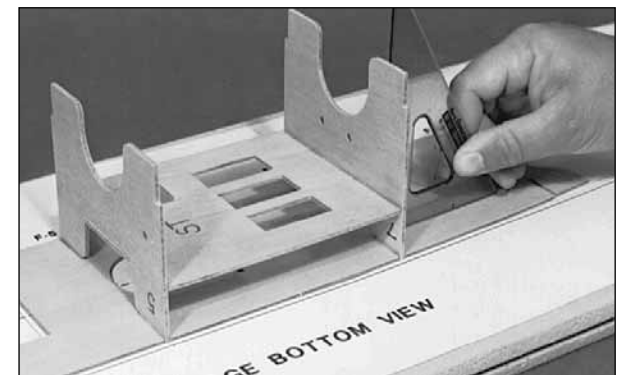

- 13. Glue in the die-cut 1/8" plywood former **F-7** and the die-cut 1/8" plywood **Servo Tray (ST)**. F-7 must also be perpendicular to the crutch.

□ 14. Place the die-cut 1/8" plywood former **F-3** in its slot but do **not** glue it yet since its forward slant is set by the fuselage sides.

NOTE: It is helpful to keep some weights on the crutch while building the fuselage to keep it flat on the table.

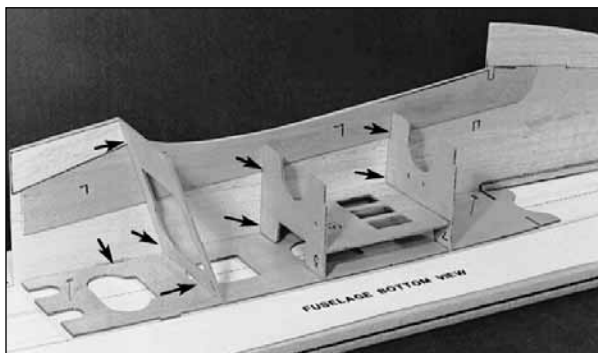

□ 15. Place the left fuselage side in position. Make sure its edge is down on the building board and tack glue it at the following places: at the lock notch near the front of the crutch; at the "bottom" edge of F-3 near the front edge of the wing saddle; at the top and bottom of F-7; and at the top and bottom of F-5. Also glue F-3 to the Crutch.

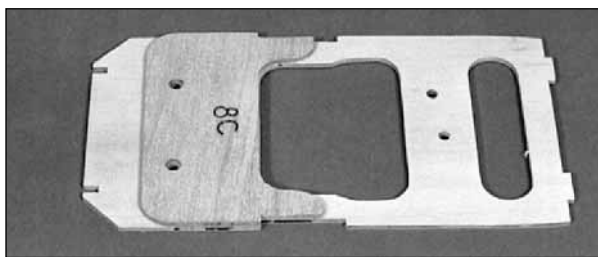

□ 16. Glue the die-cut 1/8" plywood sub-former

F-8C to the Aft face of the former **F-8A**. The 1/4" holes should line up. This assembly is now called **F-8**.

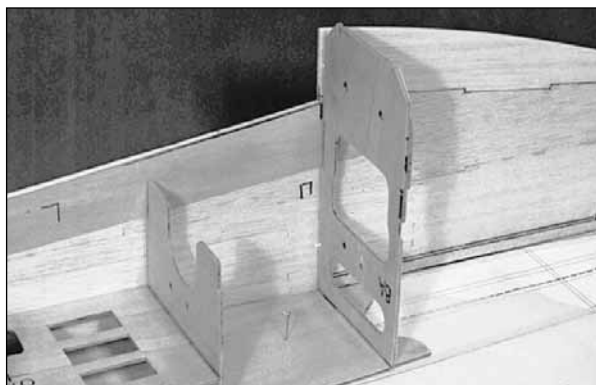

□ 17. Glue former F-8 to the Crutch. Tack glue F-8 to the plywood doubler near the notch.



□ 18. Test fit the 1/4" **Fuselage Bolt Plate** into the fuselage structure. It may be necessary to

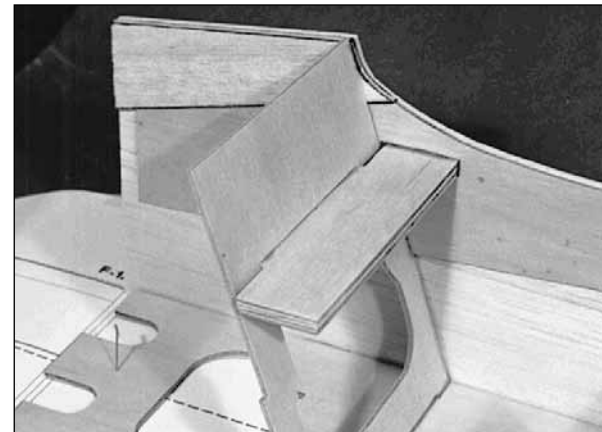

bevel the forward outboard edges slightly for an interference-free fit. When it fits well, tack glue it into the structure with CA.

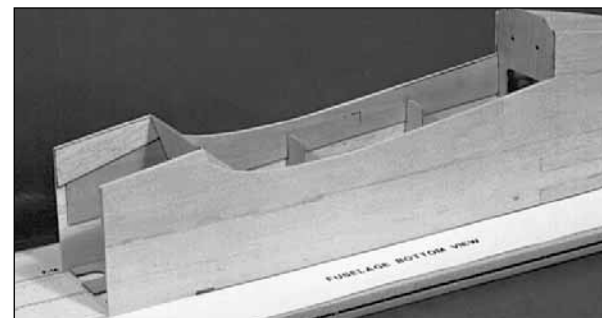

□ 19. Work the right fuselage side into place. Check to see that all the notches are properly engaged and if need be, make adjustments. Apply thin and/or medium CA to all the joints between F-3 and F-7.

□ 20. Glue F-8 to both fuselage sides from the wing saddle area to the middle of F-8, but do not worry about gluing it near the crutch yet.

21. Drill 5/64" holes through the two punch marks in the die-cut 1/8" plywood **Tail Wheel Plate (TW)**.

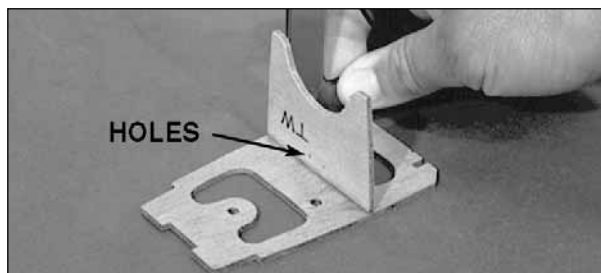

22. Glue the die-cut 1/8" plywood **Tail Wheel Plate (TW)** to former **F-10**, making sure they are perpendicular. Make sure the number on F-10 faces down.

23. If there is an additional vertical web on the nylon tail wheel bracket, trim it off so the part resembles the one in the photos.

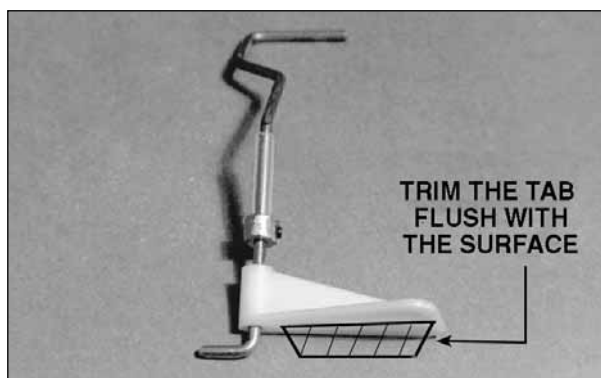

24. If there is excess length at the top of the tail wire, trim it off with a cut-off wheel so there is only about 3/8" remaining after the bend.



25. Place the 5/8" long piece of 1/8" O.D. brass tubing over the top end of the wire. Squeeze the exposed end of the tube firmly with pliers to flatten it. Check the parts over the fuselage top view to make sure they match up well. Silver solder the brass tube to the top of the tail wheel wire (see below).

TIPS FOR SILVER SOLDERING

Use this process when soldering metal to metal such as brass tube to wire, or pushrod ends to wire.

- Thoroughly clean the items to be soldered with alcohol or degreasing solvent.
- Roughen the area to be soldered with fine sandpaper. Then clean again.
- Assemble the items to be soldered.
- Apply a small amount of soldering flux. Acid based flux works best when one or more of the items is steel.

E. Heat the metal with a soldering gun or iron, and apply solder to the metal. The metal must get hot enough to melt the solder and the solder must freely flow into the joint.

F. Do not move the parts until the solder has cooled.

G. Clean off the excess flux with alcohol or solvent. Coat the parts with a very fine film of oil.

H. Test the joint by pulling hard.

26. Mark the location of the **Metal Ball** on the flat spot. Drill a 1/16" hole at the mark.

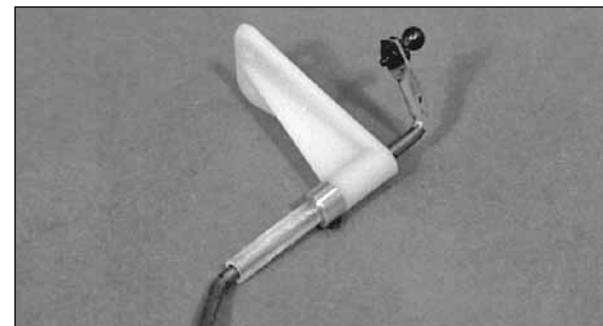

27. Attach the ball permanently to the tail gear with the **Small Nut** provided. Put a drop of 5-minute epoxy on the threads to prevent it from vibrating loose.

28. Use the **4-40 Set Screw** to set the collar at the height shown on the fuselage side view, but orient the set screw so small adjustments can be made later if required.

- 29. Roughen the tubular **Nylon Bearing** on the tail wheel wire with sandpaper so glue will stick to it.

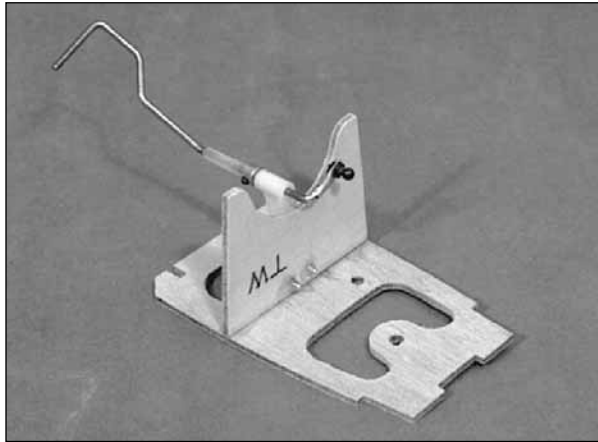

- 30. Put a small drop of 5-minute epoxy on the Nylon Bracket where the two bolt holes are. Screw the Nylon Bracket to **TW** with two **#4 x 3/8" Sheet Metal Screws**. Then put a drop of epoxy on the threads of the Sheet Metal Screws to prevent them from loosening.

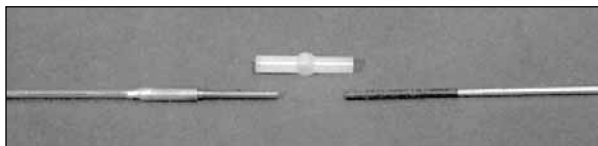

- 31. Cut 8" off one end of the **.074 x 35"**

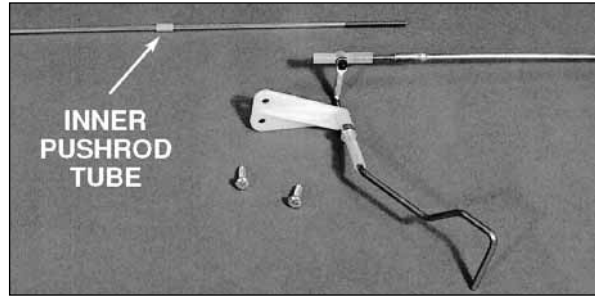

Threaded Both End Rod. Place a brass **Threaded Coupler** over the unthreaded end of the 8" piece. Measure the length of the assembly. Cut length off the wire until the total assembled length is 8-1/2". Slide a 5/16" length of inner pushrod tube over this piece of wire as shown on the plans. Silver solder the Brass Coupler to the wire.

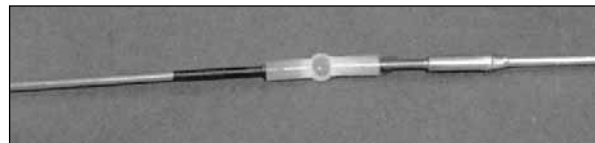

- 32. Screw the Brass Threaded Coupler of the wire well into one end of the **Nylon Two-Ended Ball Link**. Screw the remainder of the 35" rod that you cut in the previous step into the other end of the Ball Link.

- 33. Test fit the pushrod linkage onto the tailgear assembly. Oblong the rudder pushrod hole in F-10 sideways to allow for movement (see next photo).

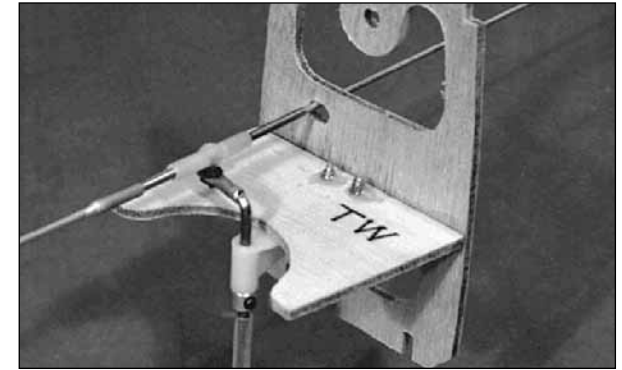

Adjust the wheel collar height for best alignment of the pushrod. Apply some threadlocker to the 4-40 set screw and tighten it snugly. Remove the pushrod.

- 34. Slide five 5/16" lengths of inner pushrod over the rudder pushrod and space them as shown on the plans.



- 35. Place the F-10/TW assembly in position between the fuselage sides. It should be located using the notches in the aft fuse doublers. Work a piece of masking tape beneath the fuselage and use it to pull the sides to the formers. Use a 90 deg. triangle to make sure the former is vertical. Pull the upward facing edges of the fuselage sides together with another piece of masking tape.

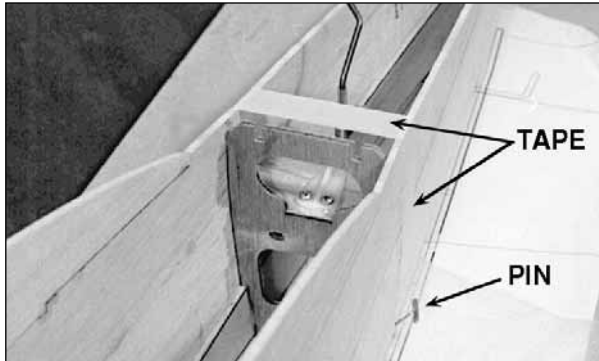

□ 36. Make sure the fuse is centered over the plans and use a couple of pins to hold it there. When it is aligned, apply a generous bead of medium CA to the joints of the fuselage sides, F-10, and TW.



□ 37. Fit F-9 into position over its location on the plans and hold it with tape using the same technique you used with F-10. Make sure it is vertical with its number facing forward. Glue it in with medium CA.

□ 38. Glue the unglued portion of F-8 and the aft end of the crutch to the fuselage sides.

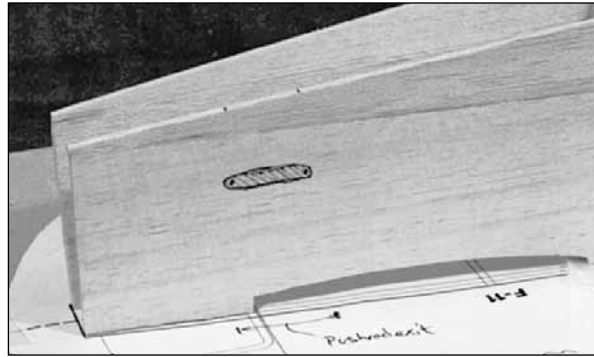

□ 39. Mark and cut-out the rudder pushrod exit where shown on the fuselage plans. Bevel the exit with a sharp knife at its front from the inside and at its back from the outside to allow the outer pushrod tube to exit at the angle shown on the plans.



□ 40. Work the wire portion of the rudder pushrod through the exit, then through the rudder pushrod holes in all the formers forward through F-7. Hook up the ball link to the tailgear ball. You may need to make a slight outward bend in the pushrod wire just aft of the ball link to allow it to exit without binding.

□ 41. Work a lightly sanded 17-1/4" long **Outer Pushrod Tube** through the formers around the wire, starting at F-7 and ending at F-10. Glue the outer pushrod tube to formers F-7, F-8, and F-9, but not F-10.



□ 42. Cut a 5" long piece of outer pushrod tube and lightly sand the outside. For best results, taper one end as shown.

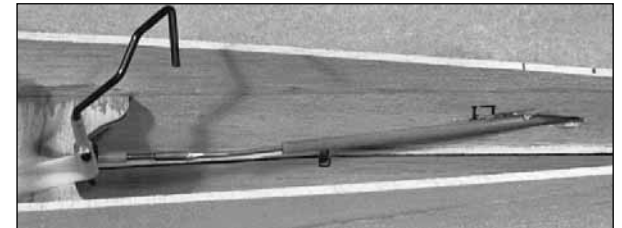

□ 43. Test fit the tube into the pushrod exit and make sure the balsa wood is adequately cleared. Glue in the tube.

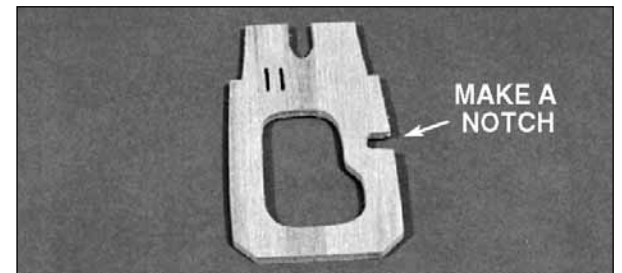

□ 44. Cut into the pushrod hole in the die-cut



1/8" plywood former **F-11**, making it a notch. Test fit F-11 into the fuselage. Make adjustments to the notch if necessary. Glue in F-11.

□ 45. Lightly sand a 22" length of outer pushrod tube and feed it through the elevator pushrod holes in the formers. Glue it to formers F-7 through F-10. **NOTE:** Refer to the plans for the location of the aft end of the tube. It protrudes past F-11 about 1/4".

□ 46. Cut two 2" lengths of 1/4" balsa triangle stock and use them to reinforce the joints of TW and the fuselage sides (see photo below).

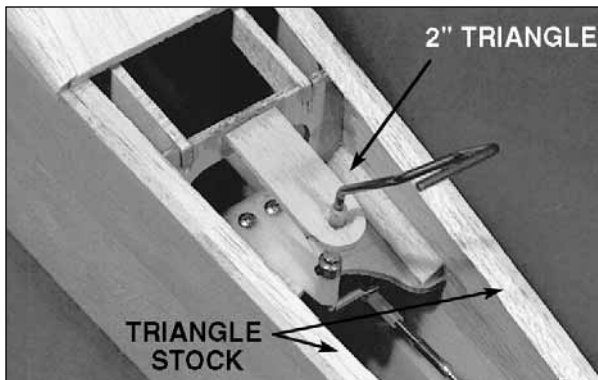

□ 47. Cut two 11-1/4" lengths from the supplied 1/4" x 36" triangle stock. Test fit these in the aft

fuselage as shown. Notice on the plans (sideview) that they stop 1/2" short of the aft end of the fuselage sides. Glue them in place.

□ 48. Test fit the die-cut 1/8" balsa **Radiator Keels** into the slots in F-8, F-9, and F-10. You may be required to shorten them slightly. Glue them in place (see the photos at steps 50 and 51).

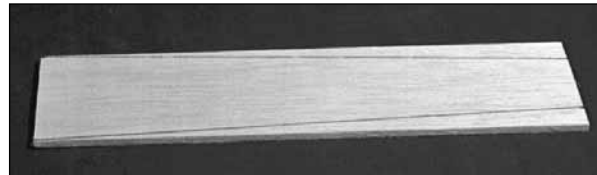

□ 49. Cut an 11-3/4" length from the 3/16" x 3" x 24" soft balsa **Aft Fuse Bottom Sheet**. Cut it down until it is just wider than the two Keels.

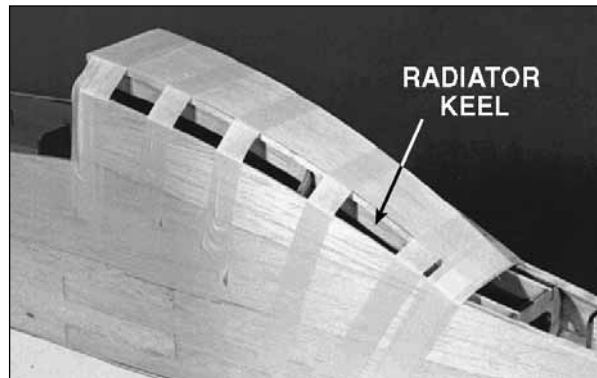

□ 50. Wet the sheet with water. Apply medium CA glue to the keels, F-8, and F-9. Pull the sheet into place with multiple pieces of masking tape. Allow the wet wood to dry thoroughly.

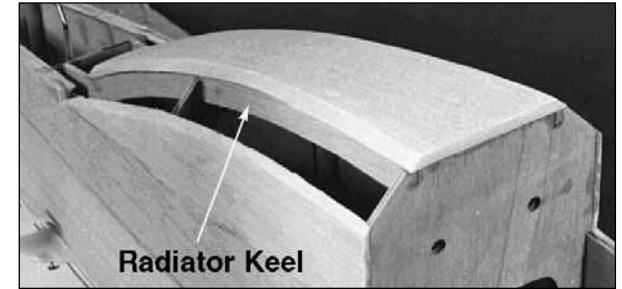

□ 51. Use a knife, a razor plane, and a coarse sanding block to bevel the radiator sides and bottom as shown. Look at the cross-sections on the fuselage plans for reference.

□ 52. Use the pattern provided on the plan to cut two **Radiator Corners** from the 1/4" x 2" x 24" soft balsa sheet.



□ 53. Glue the Radiator Corners to the fuselage. Wetting these parts may be required, depending on the wood. You may wish to use tape to hold these parts down while the glue sets.

NOTE: At this point, you should remove the fuselage from the building board and reinforce difficult to reach glue joints from the inside.



□ 54. Roughly shape the Radiator Corners with a knife and a razor plane. Save the final shaping until after the aft bottom sheeting has been applied.

□ 55. A pattern for the gauge to set the firewall angle is provided on the plan, since the Plywood Fuse Doublers alone cannot be counted on to set the correct 1.75 deg. of down thrust. Glue the pattern to a piece of plywood or cardboard and cut it out.

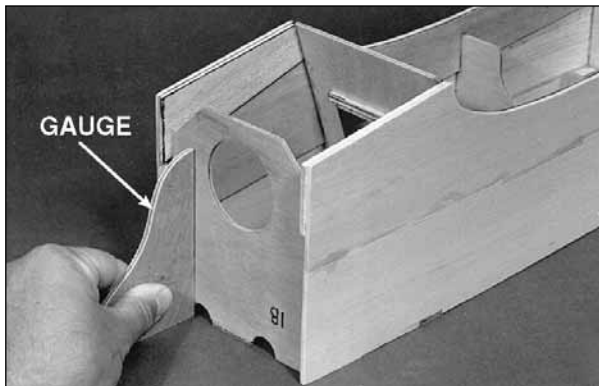

□ 56. Test fit the die-cut 1/8" plywood **Aft Firewall (F-1B)** into the front of the fuselage and check the angle with the firewall gauge. Remember, the Crutch and Doublers also set right thrust. Make any necessary adjustments.

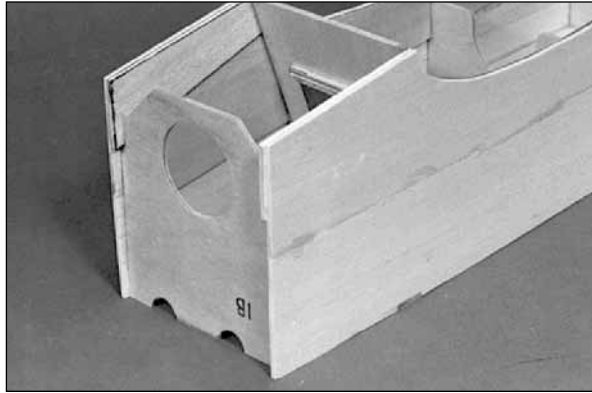

□ 57. Glue in F-1B starting at the crutch. Use the firewall jig to make sure the angle is correct.

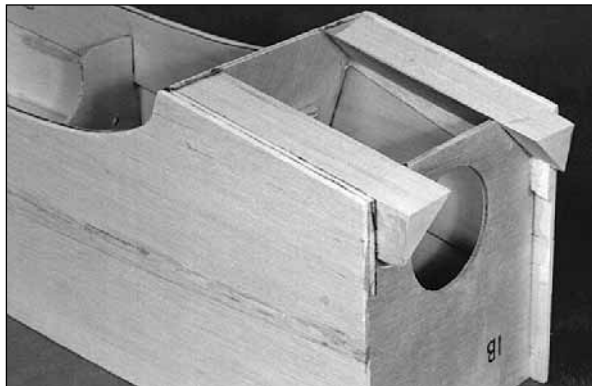

□ 58. Bevel the aft edges of the two 5" long balsa 1" triangle pieces so they match up to F-3. Glue in the triangles.

□ 59. Apply a fillet of 30-minute epoxy to the inside corner of the firewall and the fuse sides. You also may want to use epoxy to fuelproof the corners that will be difficult to get to after the **Chin Block** is put on. Also apply a fillet of epoxy around the **Fuselage Bolt Plate**.

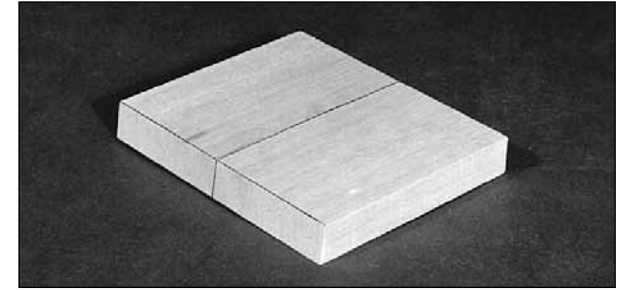

□ 60. Glue the two 3/4" x 2-5/8" x 4-3/8" shaped balsa **Chin Block** pieces together as shown. The angled end of the block aligns as a projection of F-3. Glue the block to the fuselage.

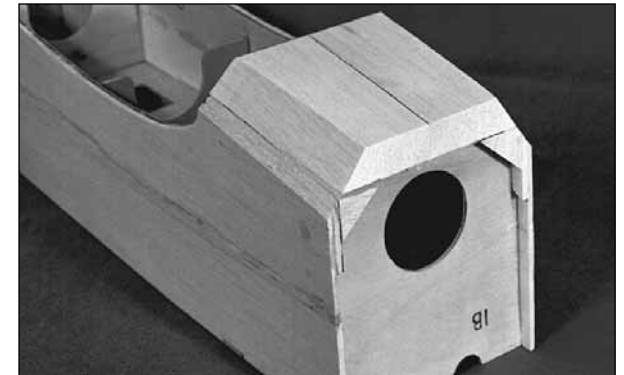

□ 61. Roughly shape the Chin Block. Final shaping of the block will be done later.

MOUNT THE WING TO THE FUSELAGE

□ 1. Run a 1/4" drill bit through F-8 and F-8D to clean out the holes so the dowels will fit through.

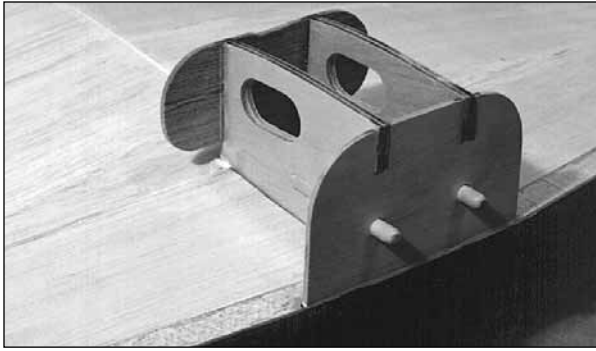

□ 2. Round the ends of the 2-1/2" long 1/4" **Dowels**. Insert the Dowels into the wing (do not glue yet).

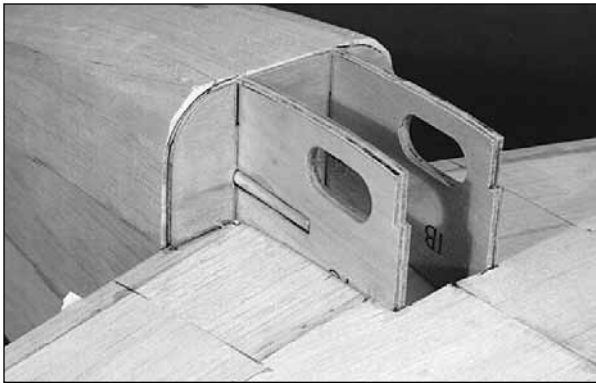

□ 3. Test fit the wing onto the fuselage. The fuse dowel holes may have to be loosened up a little more to allow the wing to go on smoothly.

□ 4. Adjust the parts until the wing fits well on the saddle. The CLE (Center Leading Edge) and the wing saddle may require slight adjustments.

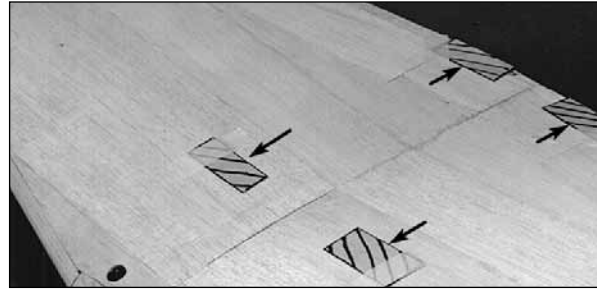

□ 5. Tape some scrap 1/32" plywood (from the wing fillet base die-cut sheet) to the wing skin near the trailing edge and over the spar to simulate the die-cut plywood **Fillet Base** being in place. Again test fit the wing to the fuselage. If there is much interference preventing the wing from comfortably fitting down on the saddle, shape the wing dowel holes oblong and adjust the dowel slot in the wing structure until the interference is gone.

□ 6. Draw a centerline on the CLE to give you a reference when aligning the wing.

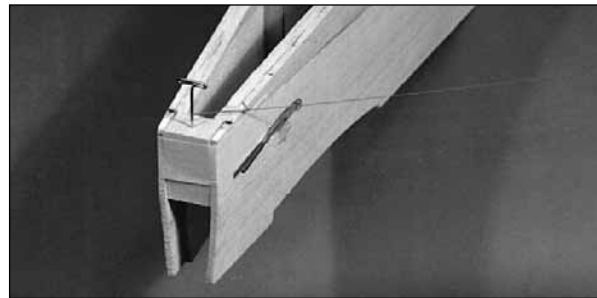

□ 7. Tape a piece of scrap balsa between the fuselage sides at the aft end of the fuselage. Stick a T-pin in the scrap balsa on the fuselage centerline. Tie a five foot length of string to the pin, which will aid in checking the wing alignment.

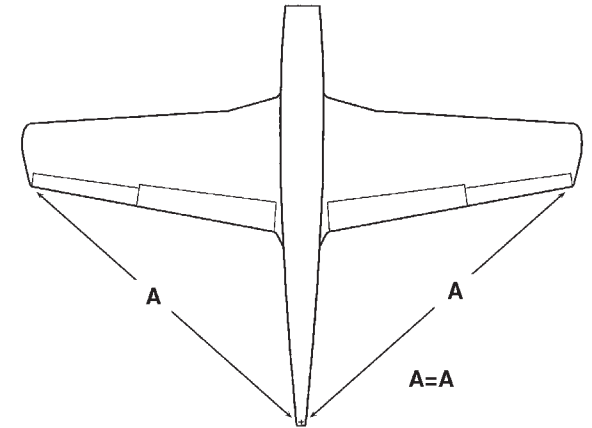

□ 8. Put the wing in position on the fuselage. Hold the string (with one end attached to the pin at the tail) up to a wing tip. Put a piece of tape on the string to mark the intersection of the string and the wing tip. Swing the string over to the other wing tip and check to see if the distances are the same (see diagram). Adjust the position of the leading edge of the wing until the wing is properly aligned.

NOTE: Make sure the wing is held securely and cannot shift while you are drilling the mounting holes.

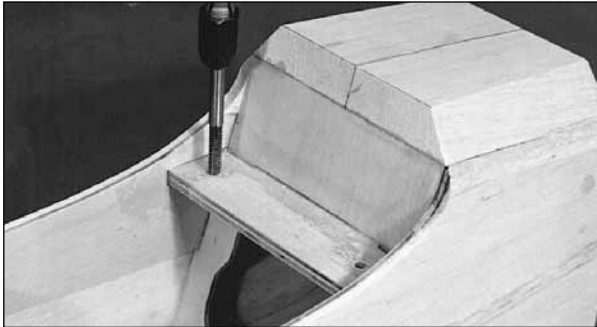
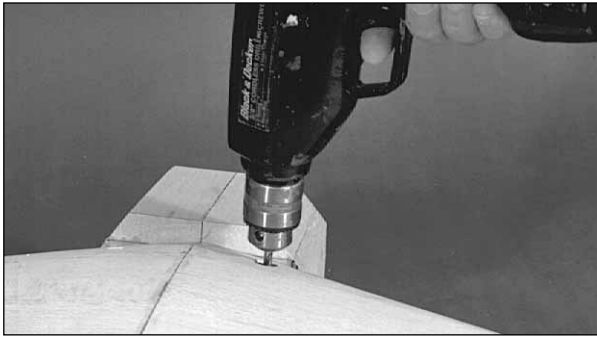

□ 9. Drill through the two holes in the Wing Bolt Plate and through the Fuselage Bolt Plate with a #10 drill (or 13/64"). Remove the wing and tap the holes in the **Fuselage Bolt Plate** with a 1/4-20 tap. Wick some thin CA into the threads to harden them. Allow the CA to cure fully. Run the tap through the threads again to clean up the threads. Drill out the holes in the **Wing Bolt Plate** with a 17/64" bit.

□ 10. Bolt the wing to the fuselage. Check to be sure the dowels at the TE of the wing are centered in the slots. Apply medium CA to the dowels at the slots and allow to cure. Remove the wing and make sure the dowels are thoroughly glued in.

ATTACH THE STAB AND FIN

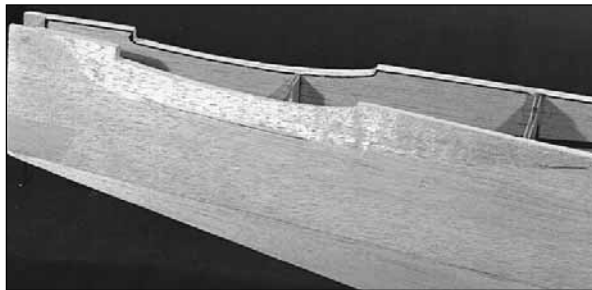
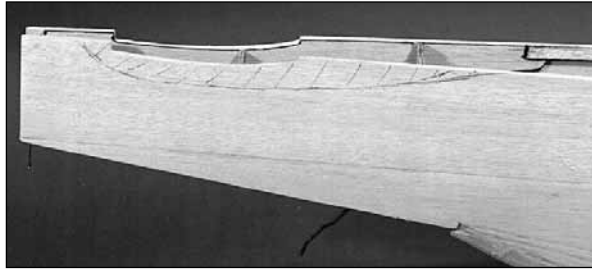

□ 1. For scale accuracy, the fuselage sides in the area of the stab saddle need to be contoured. Study the cross sections on the plans as well as the photos. Razor plane and block sand the fuselage to obtain the proper shape.

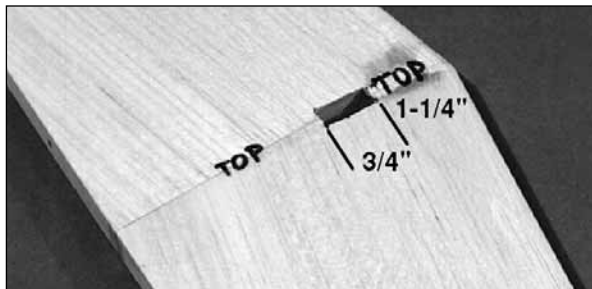

□ 2. Mark one side of the stab to be the top (it doesn't really matter which). Put a mark 1-1/4" behind the leading edge at the center of the stab. Put another mark 3/4" behind that one.

□ 3. Use a sharp knife to cut a slot in the stab skin between the two S-1 stab ribs and between the marks. Cut the same slot in the bottom skin.

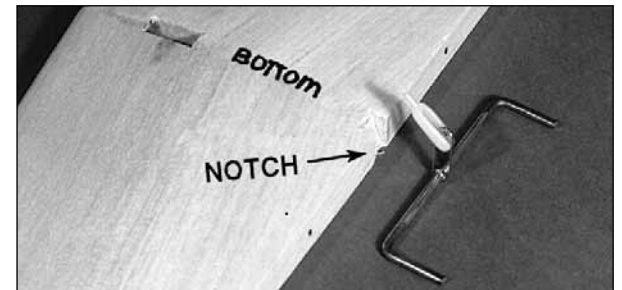
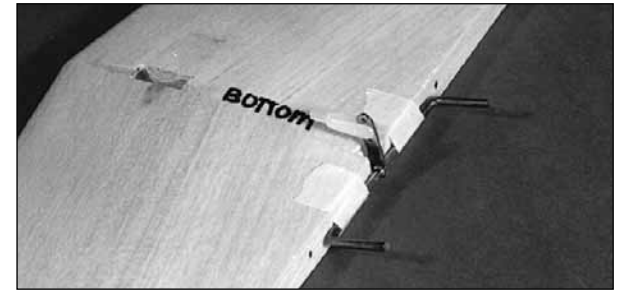

□ 4. Make a notch favoring the bottom of the stab to allow the horn on the bent wire elevator joiner to protrude into the stab and rotate for up and down elevator control (see the photo and fuse side view plan).



□ 5. Make sure the fin LE will fit through the slot

in the stab. Shave the sides of the LE slightly as needed.

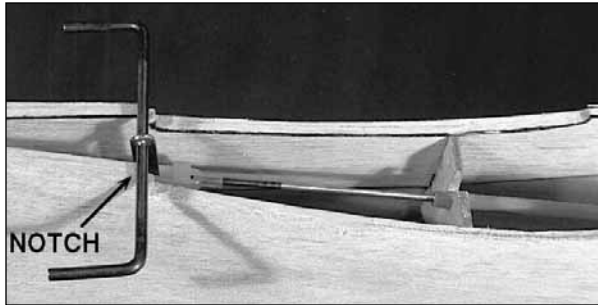

□ 6. Cut a notch at the aft edge of the stab saddle to give the Elevator Torque Rod room to rotate.

□ 7. Test fit the stab into the stab saddle. Make small adjustments to the saddle if necessary for a good fit.

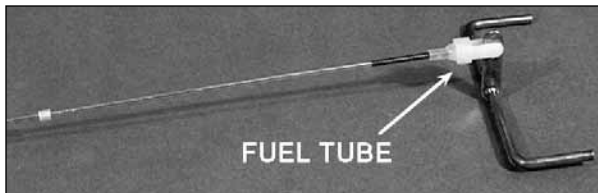

□ 8. Make an elevator pushrod by sliding six 5/16" long pieces of **Inner Pushrod Tube** over a **.074 x 34" Pushrod Wire**. Distribute them as shown on the plans and cut the wire a little longer than shown on the plan. Put a 3/16" long piece of medium fuel tubing over a **Nylon Clevis** to assure it will not open. Screw the Nylon Clevis well onto the end of the pushrod wire. Attach the Clevis to the Elevator Torque Rod.

□ 9. Insert the pushrod assembly into the outer tube that was previously installed in the fuselage.

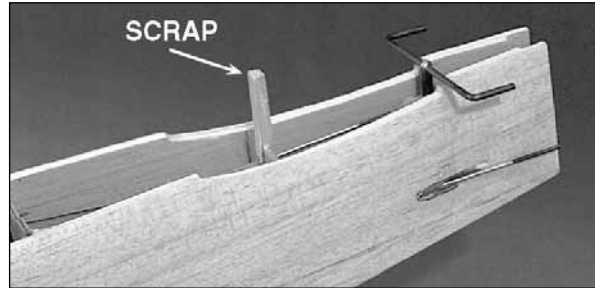

□ 10. Stick a short piece of 1/4" scrap balsa into the slot in F-11 to simulate the rudder post. Bolt the wing onto the fuselage for reference.



□ 11. Set the stab in the stab saddle. Check the alignment of the stab with the wing from the front and rear of the model. Check from the top view of the model to see if the stab is square to the fuselage centerline.

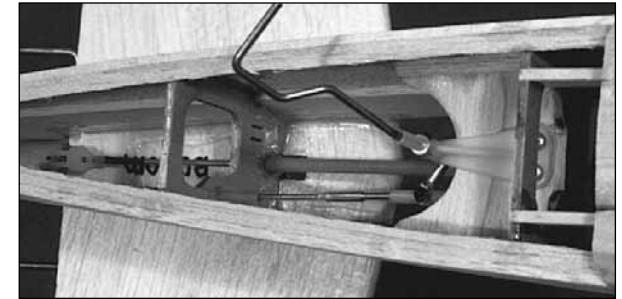

□ 12. Tack glue the stab on with medium CA and again check its alignment. Glue the stab to the saddle from the inside and outside of the fuselage with 30-minute epoxy. Be sure to glue it to F-11.



□ 13. Work the fin into position. Trim any fin sheeting away that prevents the fin TE from standing vertical when you view it from the side (the fin LE may also need to be shortened slightly).



□ 14. Check the alignment of the fin from the front and rear of the model to see if it is vertical. Glue it in with thin and medium CA. Apply some epoxy to the intersection of the fin LE and F-11, being careful to avoid getting glue in the elevator pushrod. Glue the fin trailing edge to the aft fuselage sides with thin and medium CA.

PREPARE THE ELEVATORS

□ 1. Locate the 11-1/4" long double tapered balsa **Elevators**. Check the taper of the elevators over the plan to make sure you have the correct parts.

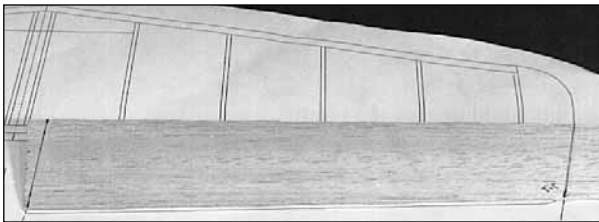

□ 2. Place the elevators on the plan and draw angled lines on the root and tip ends of each elevator where shown.

□ 3. Using a razor saw, cut off the ends of the elevators at the previously drawn lines.

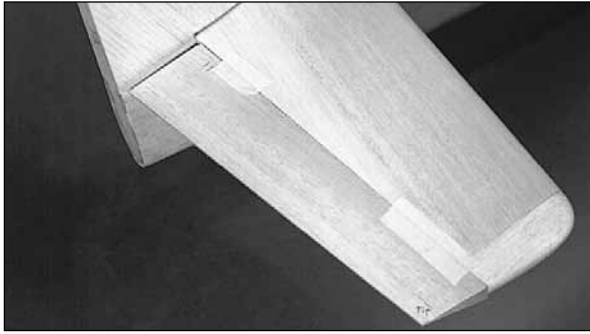

□ 4. Hold the elevators up to the stab. With the tips of the elevators aligned with the tips of the stab, mark the locations where the elevator torque rod will be inserted into the elevators.

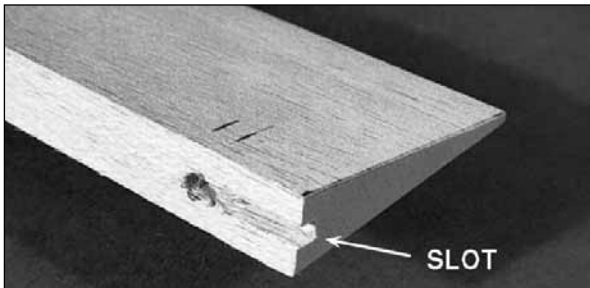
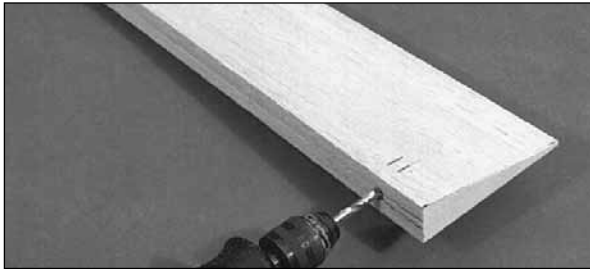

□ 5. Drill a 5/64" hole into the elevator for the torque rod. Make a slot from the hole to the root end of the elevator for the body of the rod to rest in.



□ 6. Tape both elevators to the stab. Carve and sand the tips so they conform nicely to the stab tips.

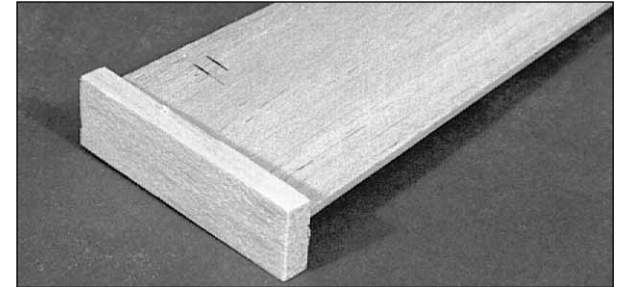

□ 7. **Tack glue** a 1/4" x 3/4" x 2-3/8" **Fillet Block** to the root end of each elevator. Cut a notch so the torque rod can pass through it.

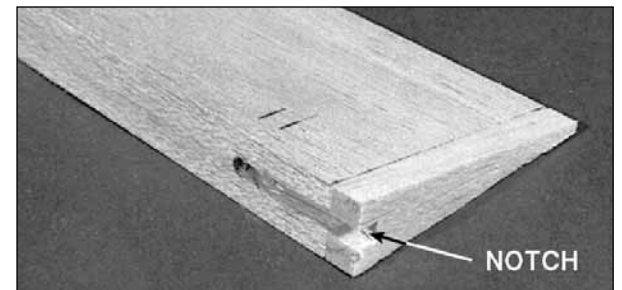

□ 8. Sand the surfaces of the blocks so they are shaped as a projection of the elevators.



9. Test fit the elevators with the blocks to the stab/fuselage. Sand the inboard edges of the blocks that touch the fuselage until the blocks fit nicely against the fuselage.



10. Make sure the elevators are **neutral**. Glue the blocks to the fuselage, then pop loose or cut through the tack glue joints to free the elevators.

11. Shape the LE of the elevators to a "V" as shown on the cross section on the plans.

FUSELAGE COMPLETION

1. Drill a 5/32" hole through the punch mark in the die-cut 1/8" plywood **Lower Tail Gear Support (LT)**. Test fit the support in place and adjust its length if required.

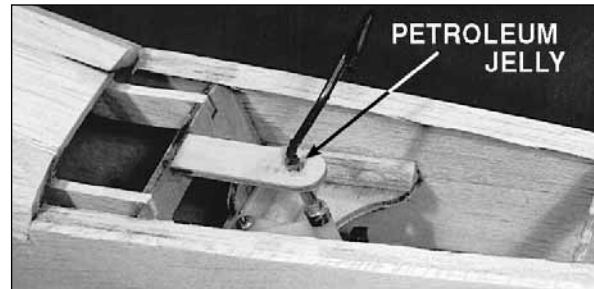

2. Put a small amount of petroleum jelly on the Nylon Bearing to keep glue out. Glue the support to F-10 and the nylon bearing tube with its bottom surface even with the lower edge of the fuselage sides.

3. The Aft Fuselage Bottom is made out of the other half of the 3/16" x 3" x 24" balsa sheet that was used to make the radiator bottom. Measure and rough cut the sheet to fit in place.

4. Drill a 5/32" hole for the tail gear wire to exit the aft fuse bottom. This hole may have to be enlarged slightly. Test fit and adjust the balsa sheet.

5. Use a sanding block to flatten the bottom edges of the fuselage sides to make sure the bottom will fit well.

6. Apply medium CA to all structure the bottom will contact including the lower tail gear support and glue the bottom in place.

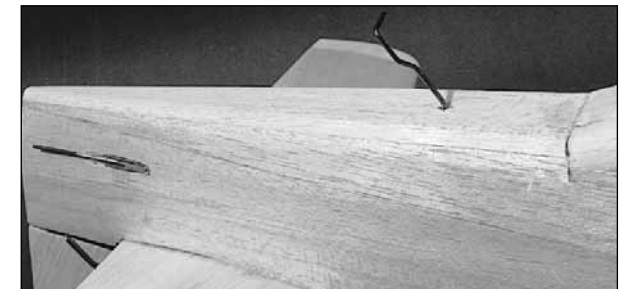

7. Look at the aft fuselage cross sections for the proper shapes for fuselage contouring. Use a razor plane and a sanding block to shape the bottom. The aft end of the bottom should be shaped with the rudder taped to the fin.

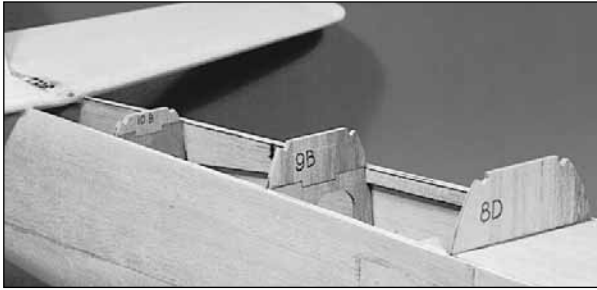

- 8. Glue the die-cut 1/8" plywood **former tops F-10B, F-9B, and F-8D** to the tops of their respective formers.

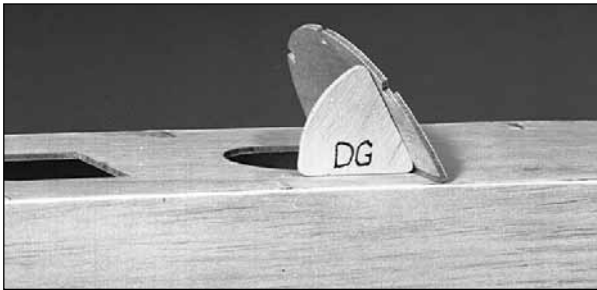

- 9. Use the die-cut 1/8" plywood **Dash Gauge (DG)** to set the angle of the die-cut 1/8" former **F-6**. Glue in **F-6**, but do not glue in the gauge.



- 10. Glue in the die-cut 1/8" plywood **former tops F-4 and F-2**.

NOTE: It is easiest to lay out your engine and mount locations now, before **F-1A** is glued on and the deck sheeting applied. If you do not have your engine and mount, draw the centerlines and offset line on **F-1A** and continue. You may have to insert blind nuts through the wing saddle later.

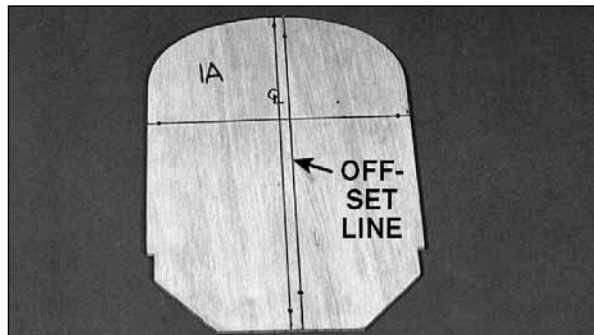

- 11. There are punch marks in the die-cut 1/8" plywood former **F-1A (firewall)**. These locate the firewall centerlines and an offset line. Draw lines connecting these points as shown in the photo.

NOTE: The same offset line is used, whether or not spacers are used, since the 9mm plywood engine mount spacers project at the same angle as a longer engine does. The bolt pattern in the firewall for the mounting of a shorter engine/mount combination can be laid out by putting the mount centerlines on the firewall offset line and horizontal centerline. The spacers can be added later.

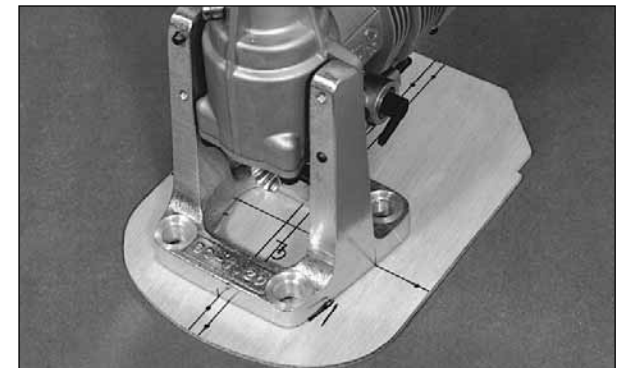

- 12. The centerline of the engine is positioned on the horizontal centerline and the offset line. The offset line is located on the (pilot's) left side of the firewall centerline. This allows the spinner to be on the centerline of the model, despite the right thrust.

□ 13. Mark the locations of the mounting bolts for your engine mount. You may find it convenient to also mark locations for the fuel lines and the throttle pushrod at this time. Drill pilot holes for the bolts.

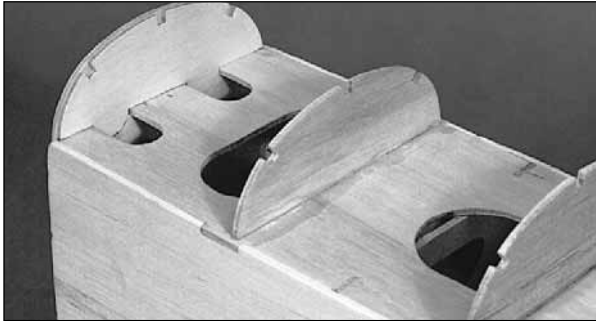

□ 14. Check the fit of F-1A to the fuselage in front of F-1B. Slide F-1C into place behind F-1A. The tops of F-1A and F-1C should be even. Make any needed adjustments to F-1A until it fits well.

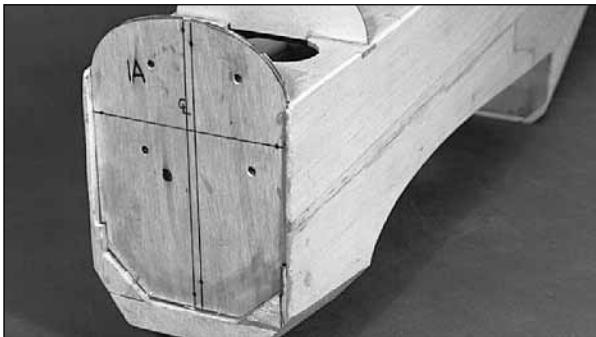

□ 15. Spread a film of 30-minute epoxy over the back of F-1A and the front of F-1B and F-1C. Assemble all the parts into position. Make sure there is a fillet of epoxy gluing the firewall assembly to the Crutch and the fuselage sides. Clamp all the parts in position until the glue has set.

□ 16. This is a good time to do additional fuel proofing inside the nose section.

□ 17. Finish drilling through the pilot holes in F-1A for the engine mount bolts.

□ 18. Locate the two 1/8" x 3/4" x 3" plywood **Firewall Backup** pieces. Position these so they will backup the engine blind nuts or soft mounts on the backside of the firewall. Glue them in with epoxy (see the photo at step 20).

□ 19. If you have all your engine/mount parts available, install them temporarily now and pull any blind nuts, etc. into place.

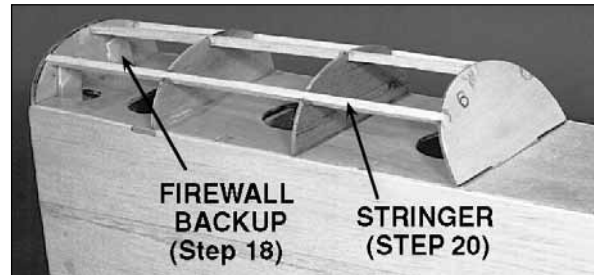

□ 20. Install the 3/16" square balsa stringers into the slots on top of the fuselage.

□ 21. Cut the two **Forward Deck** pieces out of the 1/8" x 3-1/2" x 30" balsa sheet. An approximate pattern is provided on the fuselage plan sheet.

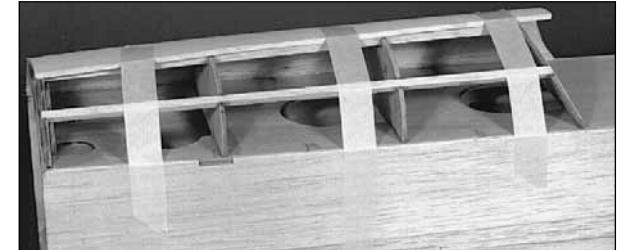

□ □ 22. Glue a forward deck sheet to the fuselage along the top edge of the fuselage side. Wet the deck using a damp paper towel. Apply glue to the formers and stringers. Bend the wood around and attach it to formers F-2 and F-4 first. You may hold it in place with masking tape.

□ □ 23. Hold the deck so it conforms with F-6. Apply some additional thin CA to the joint. Then hit it with threadlocker.

□ □ 24. Holding the deck so it conforms with F-1, apply some additional thin CA to the joint. Then hit it with threadlocker. Trim the sheeting along the centerline of the top stringer (see the photos on the next page).

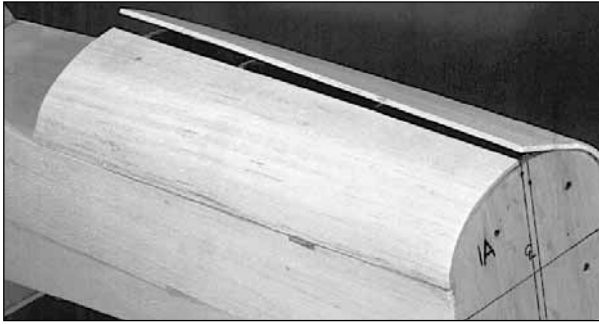

Repeat steps 22-24 for the other side of the fuselage.

□ 25. Cut the two **Aft Deck** side pieces out of the 1/8" x 3" x 30" balsa sheet. An approximate pattern is provided on the fuselage plan sheet.

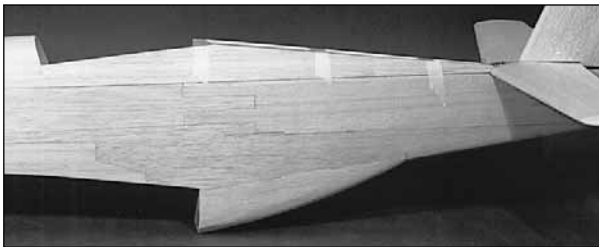

□ 26. Glue the aft decks to the top of the fuselage sides, then bend them and glue them to the formers and the stringers.

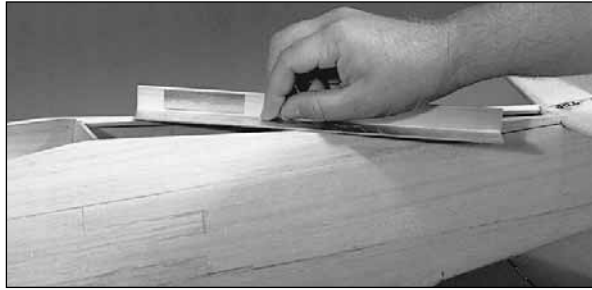

□ 27. True up the top of the aft deck sheeting and 3/16" square stringers with a razor plane and a sanding block.

□ 28. Trace the shape of the top of the fuselage deck onto the 1/2" x 3" x 18" balsa **Aft Deck Block**. Rough cut the block to shape. Carve the aft edge of the block so it will fit over the stab.

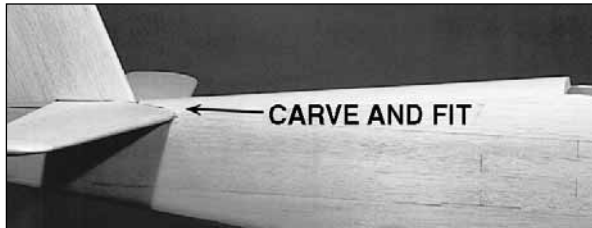

□ 29. Glue the Aft Deck Block to the fuselage. Use a razor plane and a sanding block to shape the block as shown in the fuselage cross-sections.

INSTALL THE DORSAL FIN

***NOTE:** A few early P-51D's did not have a Dorsal Fin. If you have a particular plane/trim scheme in mind, check to see if it has a dorsal fin.*

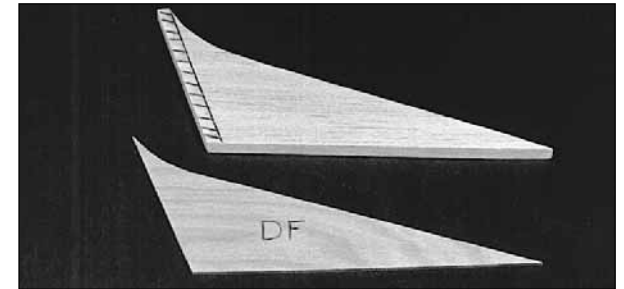

□ 1. Trace the die-cut 1/16" plywood **Dorsal Fin (DF)** twice onto the 1/4" x 4" x 8" balsa sheet provided. Note the 1/4" extension on the aft end of the balsa pieces in the photo. Draw this addition onto the sheet, and then cut out the parts.

□ 2. Draw a centerline on the aft portion of the aft deck to aid in centering the dorsal fin.



□ 3. Glue the 1/16" plywood Dorsal Fin (DF) to the fin and aft deck with medium CA.

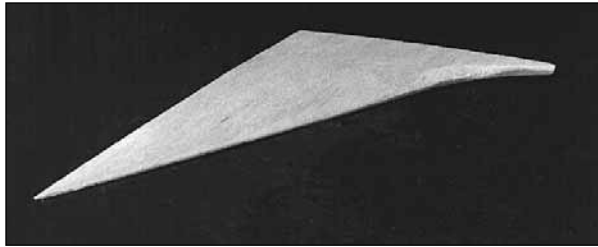

□ 4. Fit the balsa pieces on both sides of the Dorsal Fin. Start by shaping the aft edge of the balsa pieces so they overlap the fin slightly. To save work, fit and shape the balsa pieces as well as you can before gluing them on.

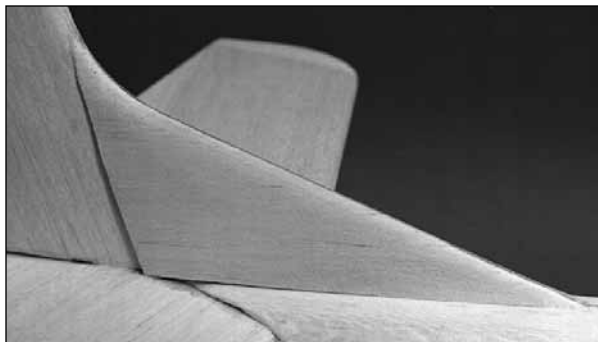

□ 5. Glue the balsa pieces to both sides of the Dorsal Fin and finish shaping them. Fill the area just behind the Dorsal Fin with scrap balsa. Filler will be required to obtain a smooth transition.

MAKE THE TOP COWLING

NOTE: The sequence below shows the installation of an O.S. .120 Surpass 4C pumper on a J-Tec JT-122SV soft mount. See the fuselage plan for an alternate engine installation.

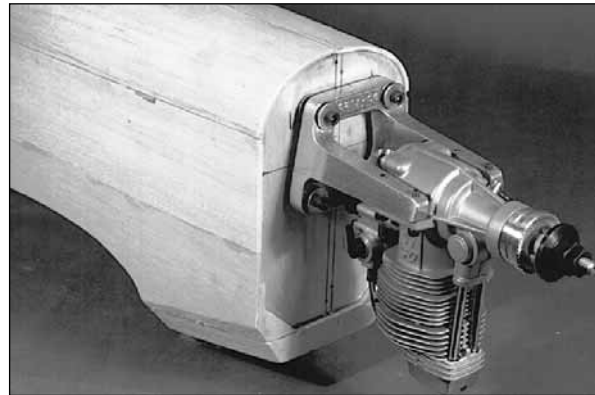

□ 1. Bolt the engine mount to the firewall. If your installation requires spacers, install them now. Bolt your engine to the engine mount. (The plans and the photos in the cowling section, on page 43, show the spacers.)

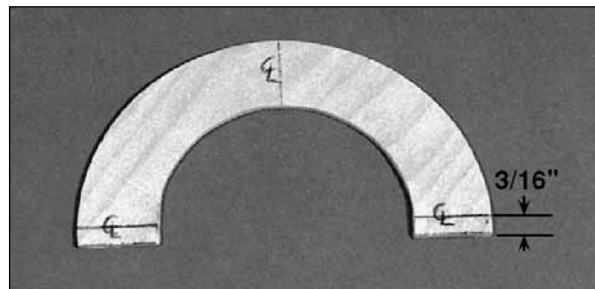

□ 2. Draw a line 3/16" above the bottom edge of the die-cut 1/16" plywood **Spinner Ring**. This is the centerline of the spinner.

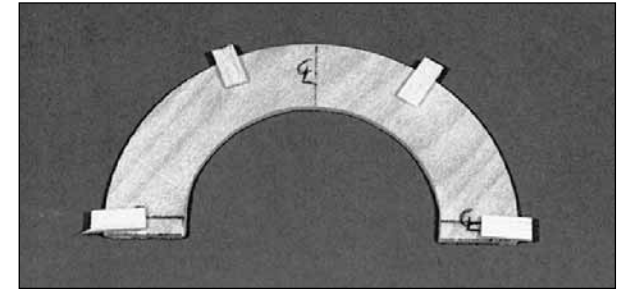

□ 3. Glue scraps of 1/16" (or 3/32" for soft mounted engines) balsa to the Spinner Ring to act as a spacer for the spinner.

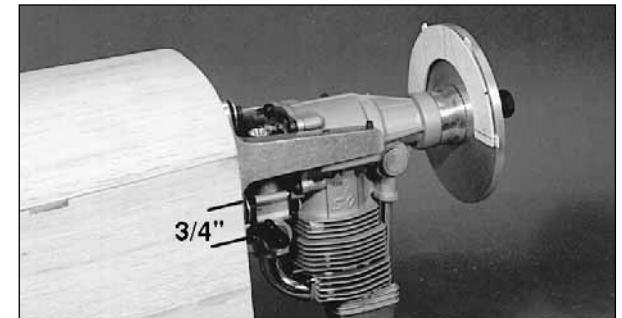

□ 4. Tack glue the spacers on the Spinner Ring to the backplate of the spinner. Mount the spinner backplate to the engine.

□ 5. Put a mark on the outside of the fuselage side 3/4" below the centerline marked on the firewall. This mark will designate the bottom of the Cowl Sides (see the photos at steps 4 & 6).

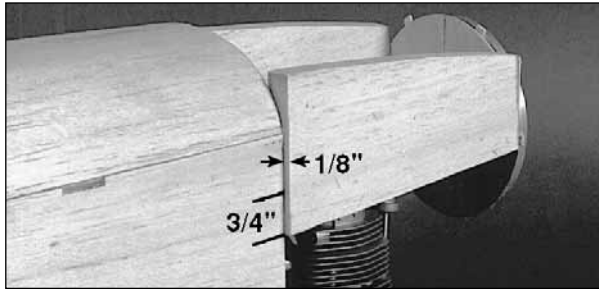

□ 6. Trim the shaped 1/2" balsa **Cowl Sides** so they fit between the fuselage sides and the Spinner Ring. The bottom edges of the sides should align with the bottom edge of the Spinner Ring and the mark you made below the centerline on the fuselage sides. Notice on the top view of the fuselage how the Cowl Sides protrude outward from the structure about 1/8" to allow for shaping.

□ 7. **Tack glue** both of the cowl sides in place. View the Cowl Sides and the Spinner Ring from the front to make sure they are on straight. Securely glue the parts in place.

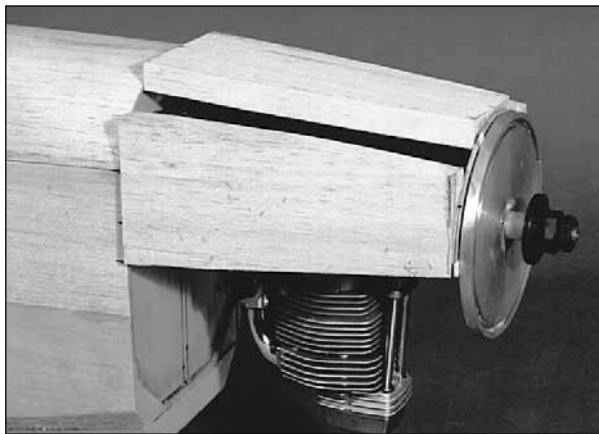

□ 8. Fit the shaped 1/2" balsa **Cowl Top** in position. Glue it securely in place.

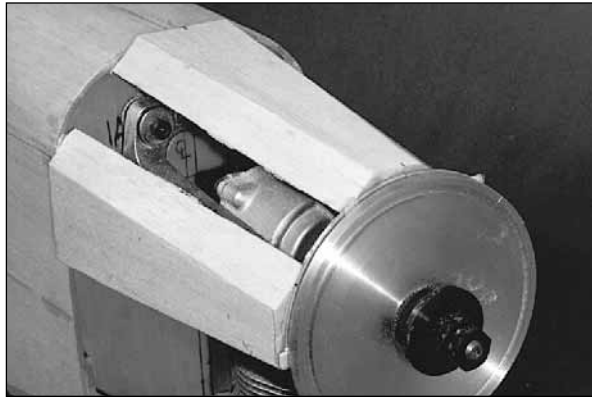

□ 9. Carefully cut the corners at an angle with a sharp knife as shown in the photos. Use a sanding block and coarse sandpaper to finish making a flat area for the Cowl Corners to fit on.

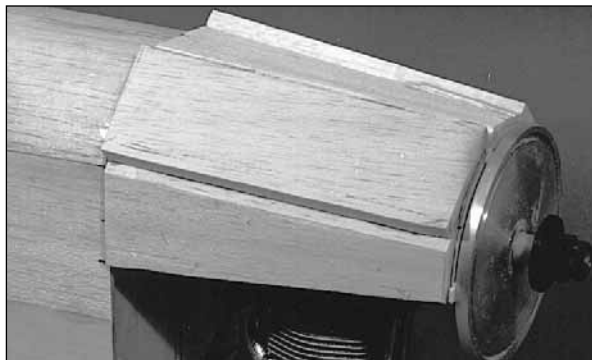

□ 10. Adjust the shaped 3/8" balsa **Cowl Corners** so they fit into place as shown. Glue them securely as shown.

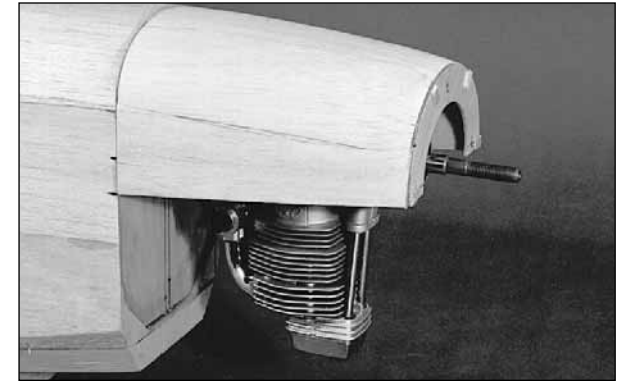

□ 11. Use a razor plane and a sanding block to shape the nose. You will want to use the spinner to help you obtain the correct shape, but remove it while shaping so you will not scratch it.

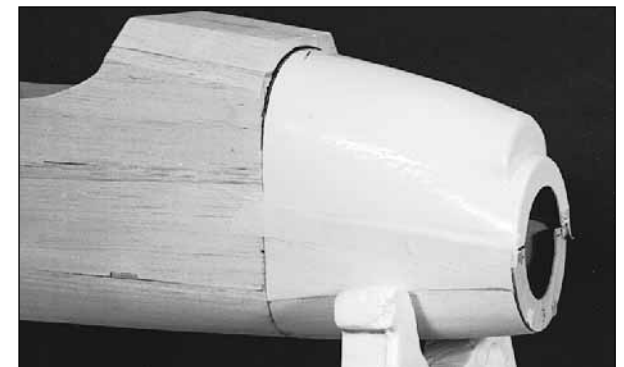

□ 12. Remove the engine and test fit the molded ABS cowl in place. Trim the cowl and/or shim the wood until the cowling fits as shown on the plan sheets. Use a pen to mark the shape of the cowl on the fuselage.

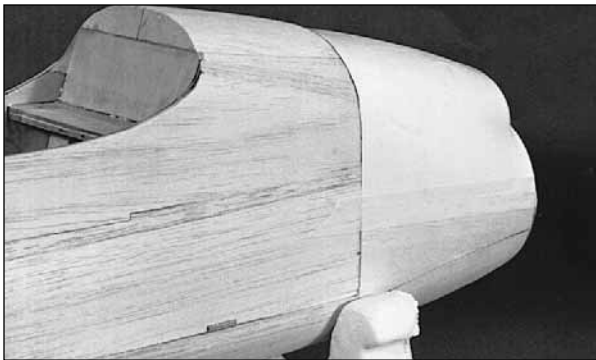
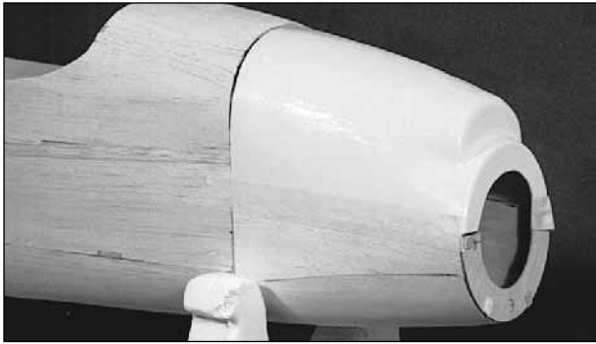

- 13. Refer to the forward fuselage cross-sections for a look at the correct shape at F-3. Use a razor plane and a coarse sanding block to shape the nose. Final shaping should be done later, after the cowl has been securely mounted and the wing fairing made. A lot of material needs to be removed.

MOUNT THE COWLING

- 1. Make sure the cowl satisfactorily fits to the front of the model and to the spinner. Trim or shim the cowl if necessary.
- 2. Mark on the cowl the locations of major cut-outs that may affect which mounting points you can use.

- 3. Tape the cowl to the fuselage and put marks on the fuselage to indicate where the mounting blocks need to go.

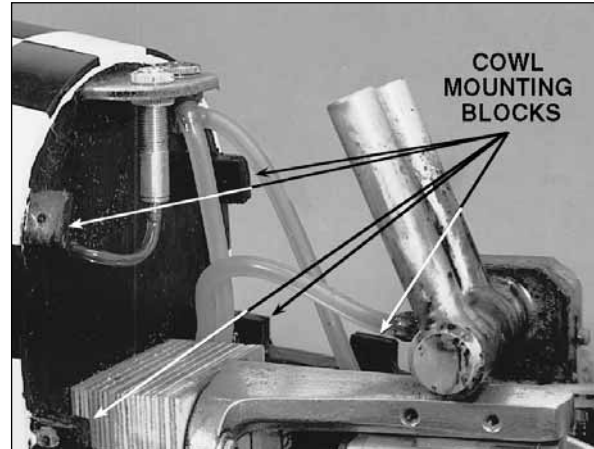

This photo shows the positioning of the Cowl Mounting Blocks and the retract air and fuel filler valves on a finished model.

- 4. Tack glue the 1/4" x 1/2" x 3/4" plywood **Cowl Mounting Blocks** to the fuselage where you put the marks. Make sure that they are inset enough so the cowl is flush with the fuselage sides. Test fit the cowl to make sure the blocks are at the proper depth.
- 5. Securely glue the blocks with epoxy.
- 6. Tape the cowl securely to the fuselage. Drill through the cowl and mounting blocks with a 1/16" bit. Remove the cowl and enlarge the holes in the cowl only with a 3/32" bit.
- 7. Mount the engine and make all necessary cutouts in the cowl and chin.

- 8. Mount the cowl and finish shaping the nose and chin of the fuselage to blend into the cowl properly.

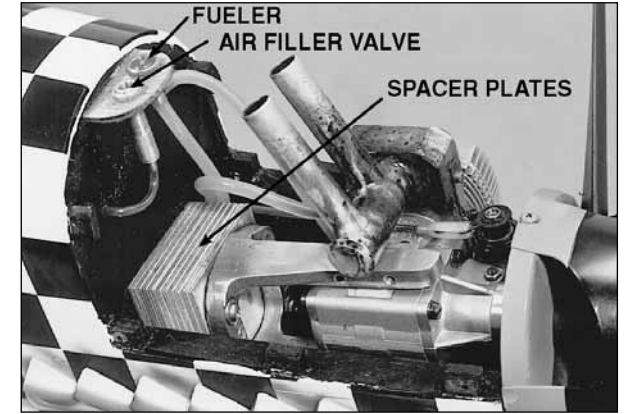

The above photo shows a side mounted Super Tigre .90 2-cycle with a Slimline Pitts style #3115 Muffler. Notice the three plywood spacer plates behind the engine mount.

BUILD THE WING FILLET

NOTE: *There are many techniques to build a wing fillet. Some modelers prefer to carve the entire fillet from balsa, others use a mixture of epoxy and microballoons to finish the fillet. If you have a favorite technique, feel free to use it. The technique described below works fine for Monokote covered aircraft.*

- 1. Remove the die-cut 1/32" plywood **Wing Fillet Bases** from their blanks. Cut the "die-cut bumps" off the aft end of the parts with a straightedge and a knife.

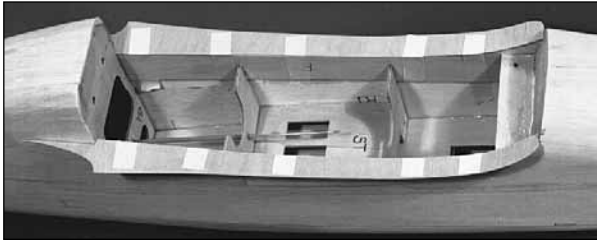

□ 2. Tape the plywood wing fillet pieces to the wing saddle as shown in the photographs. Notice how the Wing Fillet pieces overlap the wing saddle and fit around the fuselage behind the wing saddle.



□ 3. Tape a layer of waxed paper or plastic food wrap to the top surface of the wing in the wing saddle area (the shims used to simulate the thickness of the fillet in earlier steps should be removed). Bolt the wing firmly onto the fuselage. Check to make sure there are no misfits in the wing saddle and make adjustments if needed.

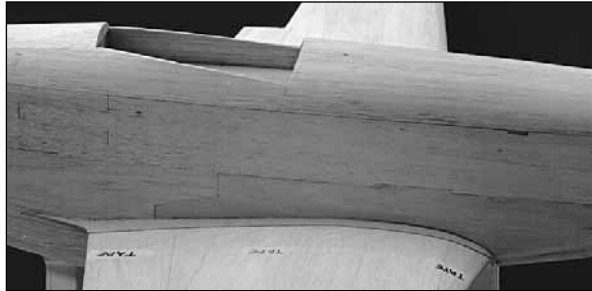

□ 4. With the wing bolted to the fuselage, glue the wing fillet to the wing saddle with medium CA.

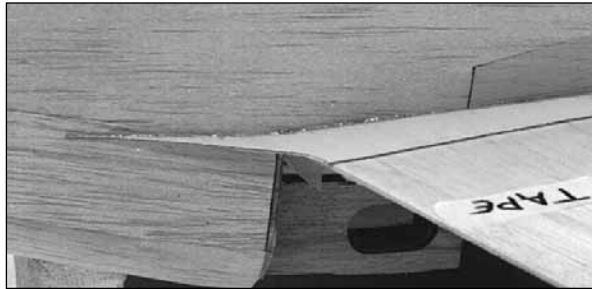

NOTE: The wing fillet may be built up with small balsa blocks and triangle stock, or you may use the technique described below.

□ 5. Cut a tapered piece of 1/16" sheet balsa as shown in the next photos. Test fit it against the wing saddle and refine the fit. A little concave curvature on the side that contacts the plywood wing fillet helps. Make a few hard triangle stock pieces to fit under the balsa strip especially toward the back end of the fillet.

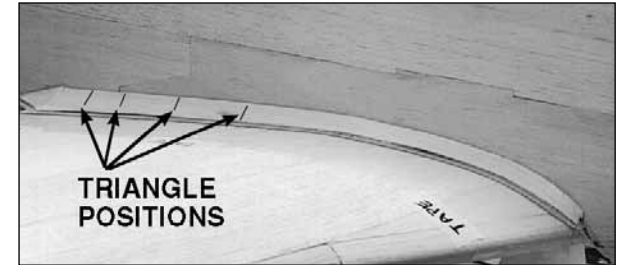
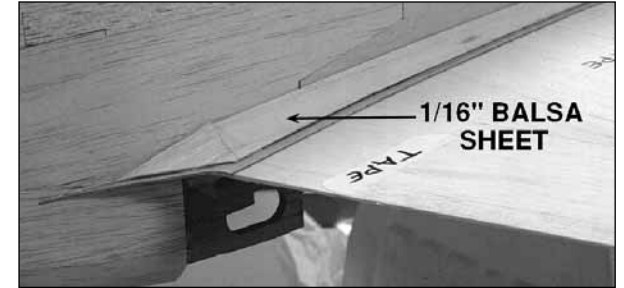

□ 6. Glue the long strip in place starting in the middle, then working toward each end. The angle of the balsa should be approximately 45 degrees from the middle forward, and flatten out some toward the back.



□ 7. Apply HobbyLite filler to the fillet. Trowel it in with a spatula as best you can. Lay a piece of waxed paper over a 4" section of the fillet. Use your fingers to contour the fillet, then carefully peel the waxed paper away. Contour the entire fillet one section at a time.



8. Flip the plane over and build the small fillet on the bottom side of the aircraft behind the wing.

9. Allow the filler to dry completely. You may have to let it sit overnight, depending on the thickness of the filler.



10. Use cylindrical sanding tools to final

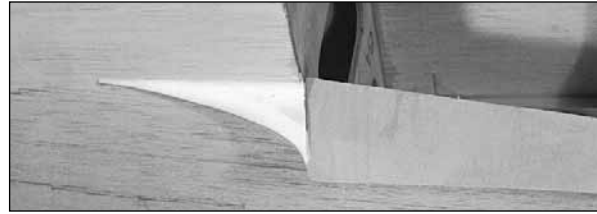

shape the fillet. Remove the wing and clean up the edges of the fillet. Wick some thin CA into the junction of the plywood wing fillet and the wing saddle from the inside the fuselage.

INSTALL THE FORWARD WING FAIRING

1. Install the wing onto the fuselage with waxed paper under the front portion of the wing saddle.

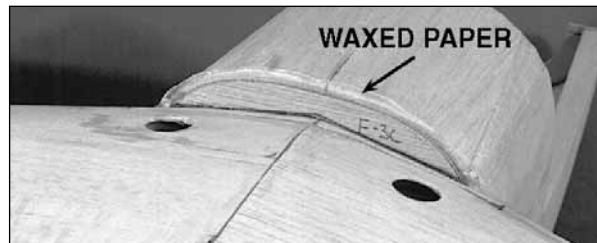

2. Check the fit of the die-cut 1/8" plywood **F-3C**. Trim the height of F-3C until it is undersized compared to the chin block height by 1/16". This will leave room for the sheeting.

3. Glue F-3C to the wing with medium CA.



4. Cut the 1/16" sheet balsa for the fairing using the approximate pattern provided on the fuselage plan sheet. Test fit and trim the sheet until it fits well. For best results, you will want to sand the sheet thinner toward its back half.



5. Glue the sheet in place for the fairing. Blend the fairing into the chin block with a sanding block. Use filler to complete the transition into the wing.

FIT THE RADIATOR

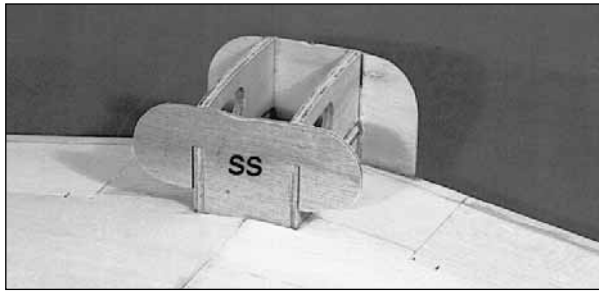

- 1. Place the die-cut 1/8" plywood **Scoop Support (SS)** in position on the bottom of the wing, but do not glue it yet.

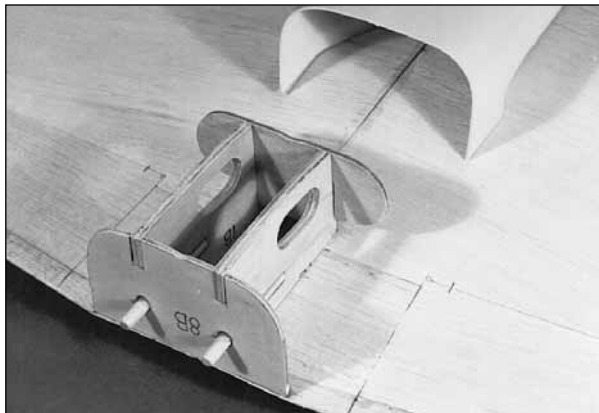

- 2. Slide the molded ABS plastic **Radiator Scoop** over the support and into position. It should slide on far enough to overlap F-8B about 1/32". Check for binding or resistance. Trim or sand the former or scoop if required for a good fit.

- 3. Glue the Scoop Support to the wing structure.



- 4. Mark the aft edge of the scoop from the inside using F-8B as a guide. Trim the scoop so it will be flush with the aft surface of F-8B.

- 5. Mount the wing to the fuselage. Test fit the scoop and check its fit with regard to the fuselage and wing. Make slight adjustments if necessary.



- 6. Finish shaping the balsa section of the radiator on the fuselage so it blends in nicely with the scoop. Cover the scoop with masking tape to protect it while shaping.

NOTE: You may glue the scoop on now with CA or epoxy, fillet it in, and finish it with the rest of the airplane. However, the easiest thing to do, as done on the prototypes, is to paint the scoop separately and glue it on after the rest of the model is finished. This technique does not give you an upper fillet (between the scoop and the wing), but an upper fillet is not important for sport flying.

DO THESE STEPS FOR OPERATING FLAPS

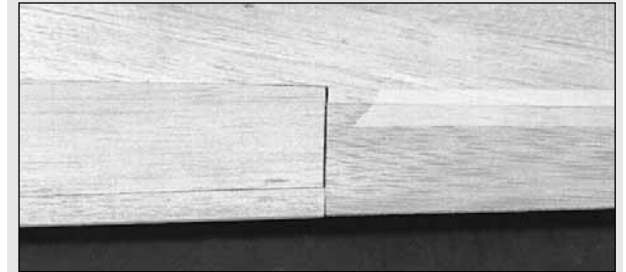

NOTE: The ailerons were fitted earlier. Check the fit of these to make sure the aileron TE and the flap TE align correctly. Keep the ailerons handy as you will use them to check the fit of the flaps as the flap hinging is done.

- 1. Make sure the location of the hinge blocks are marked on the wing and flap on the bottom skin.

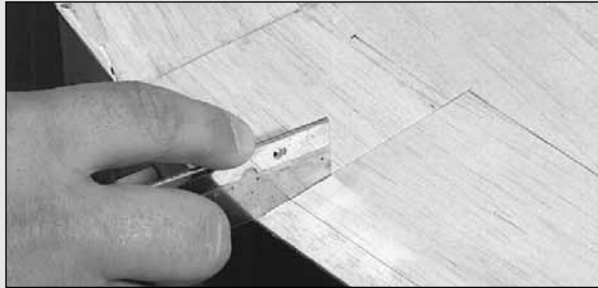
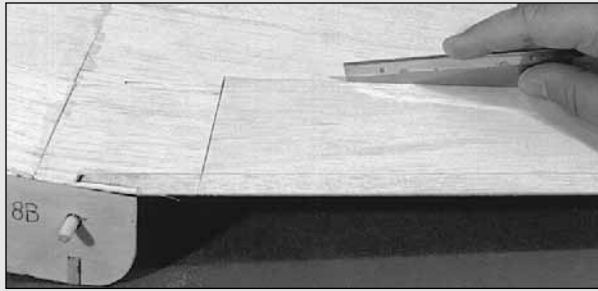

2. Cut the flap loose using a razor saw and a sharp knife. The plans show the proper cut lines.

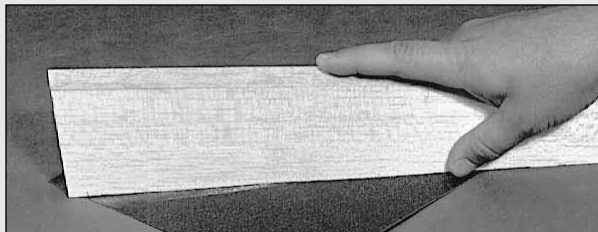

3. Use a T-bar or sandpaper taped to a flat table to even up the front edge of the flap.

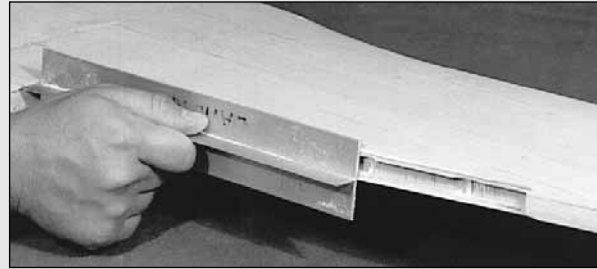
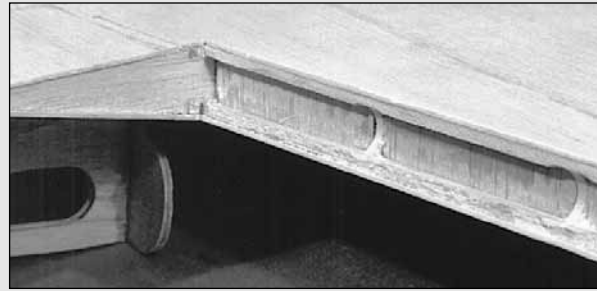

4. Use a Dremel Moto Tool with a drum sander or sandpaper wrapped around a dowel to sand the ribs back to the shear webs inside the TE. Use a T-bar to true up the aft edge of the wing sheeting at the flap.



5. Study the flap cross-sections on the plans. Notice the concave shape of the trailing edge of the wing. Use dowels of appropriate diameters to sand the proper hemispherical shape into the trailing edge of the wing. Be careful not to sand into the TE shear webs.

NOTE: Be sure to maintain the hinge locations while shaping the flap components.

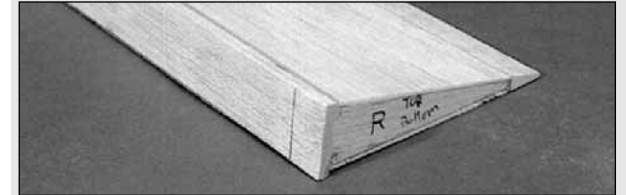

6. Glue the 3/16" x 1" x 18" balsa **Flap LE Cap** to the front edge of the flap. Sand the front portion of the flap to the cross-section shown on the plan sheet. Test fit the flap to the wing frequently to check your progress. You should be able to align the flap TE with the wing and aileron TE and have a very slight hinge gap at the hinge line.



7. When the fit is good, install the hinge point

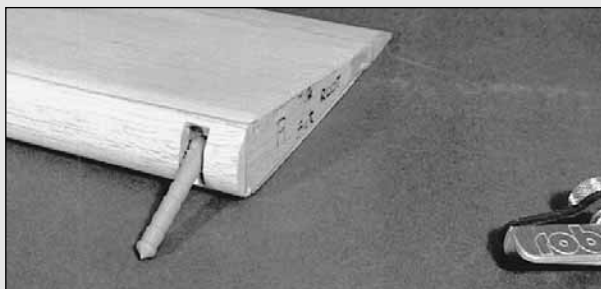

hinges. Drill 3/16" holes at the hinge locations. Use a sharp #11 knife to open a V-notch in the flap as shown in the photos and on the plans. This will allow the hinge point pivot to be in the **center of the radius of the flap LE.**

NOTE: The hinges are not glued in until after the finish has been applied.



8. Plug the flap into the wing. Check its fit and run it through its range of motion. Make any required adjustments until the flap swings freely through its range of motion (remember the flap is not required to raise above neutral).

9. Use the plans as a reference to mark the approximate location of the die-cut 1/16" plywood **Flap Servo Bay Cover** onto the bottom wing skin.

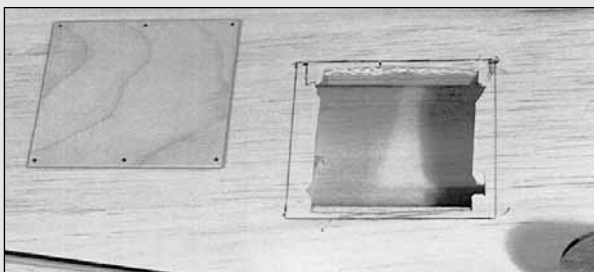

10. Cut an undersized hole into the bottom wing skin. This will allow you to locate the built in structure.

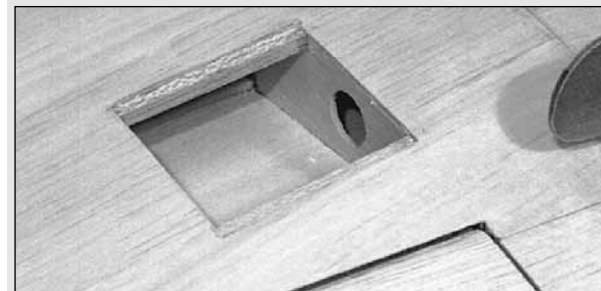

11. Trace the outline of the Flap Servo Bay Cover accurately onto the wing skin. Carefully cut out the rest of the bay and fit the cover into place.

NOTE: Unless you have a reverse throw servo, you will need to mount the flap servos in an asymmetrical manner as shown in the plans to have them both move in the same direction.

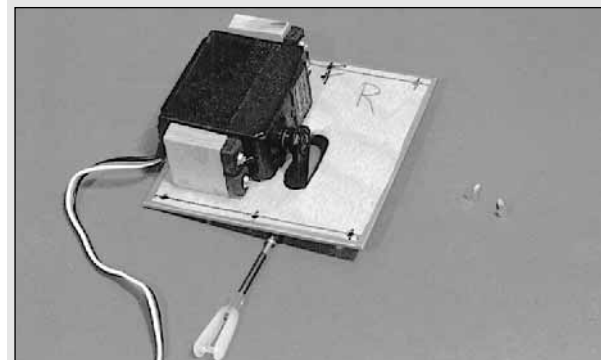

12. Mount the servos to the inside of the covers using the 5/16" x 3/4" x 7/8" basswood **Flap Servo Mounting Blocks.**

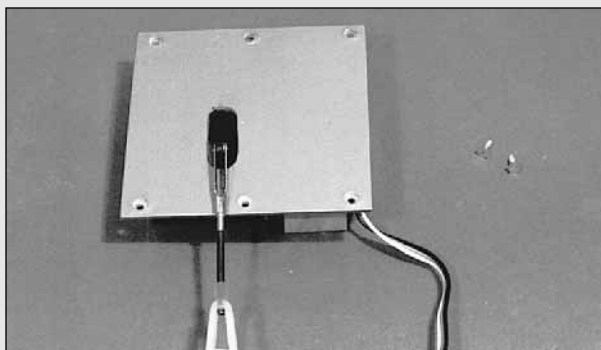

13. Cut a slot in the bay cover to allow the servo arm to exit and move back and forth.

14. Mount the bay cover to the wing, using six #2 x 3/8" flat head sheet metal screws provided. These should be countersunk into the bay cover.

NOTE: Most of the small control horns used on this plane may be cut down to 2 or 3 holes. Refer to the plans and photos to determine the length of the horns used on the prototypes.

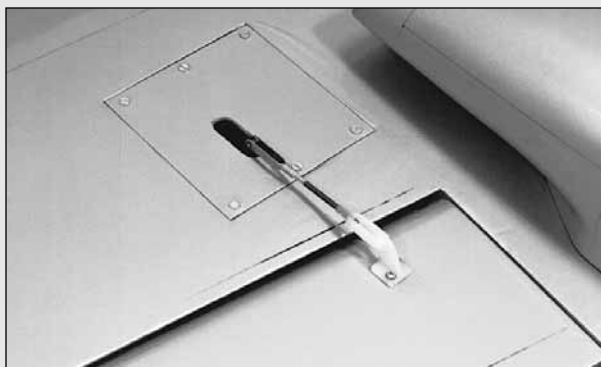

15. Locate the flap control horn straight back from the servo arm. Since the flap deflects downward, but does not deflect up at all, the horns are mounted farther aft than horns on normal ailerons, etc. See the plans and photos for the proper fore/aft flap horn location.

NOTE: The hinge points are glued in after finishing. We recommend roughening them with 80-grit sandpaper then gluing them in with epoxy.

FINISHING

FINAL SANDING

Nearly every imperfection in your wood structure will show through the covering material; therefore, before covering, you should make a final check of the entire structure. Fix any "dings," then sand the entire structure smooth using progressively finer grades of sandpaper.

FUELPROOFING

Fuelproofing may be done after covering.

1. Fuelproof the firewall area and the inside of the cowl top. Black K&B epoxy paint or 30-minute epoxy is recommended.

2. Fuelproof the inside of the fuselage forward of F-3 and the wing saddle area. 30-minute epoxy and a bent epoxy brush was used for this on the prototypes.

3. Fuelproof any externally exposed wood (eg: flap pushrod exits). Matching brush-on Perfect Paint works nicely here.

BALANCE THE AIRPLANE Laterally

SPECIAL NOTE: Do not confuse this procedure with "checking the C.G." or "balancing the airplane fore and aft." That very important step will be covered later in the manual.

Now that you have the basic airframe nearly completed, this is a good time to balance the airplane **laterally** (side-to-side). Here is how to do it:

1. Temporarily attach the wing and engine (with muffler) to the fuselage.

2. With the wing level, lift the model by the engine propeller shaft and the fin post (this may require two people). Do this several times.

3. If one wing always drops when you lift, it means that side is heavy. Balance the airplane by gluing weight to the other wing tip.

NOTE: An airplane that has been laterally balanced will track better in loops and other maneuvers.

COVERING

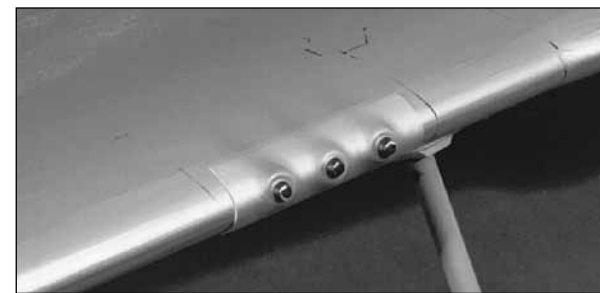

NOTE: The vacuum formed Machine Guns may be "sunk into" the wing, flush with the LE, or they may be trimmed and painted separately and glued on after covering, as on the prototypes.

Because it is assumed that you have had some previous model building experience, we won't go into detail regarding the covering procedure. **Follow the instructions included with your covering material.**

The **TRIM** section contains information on some non-aluminum colored sections of the model. You may wish to read it before proceeding with the Covering section.



When covering areas that involve fillets and sharp junctions, like the tail section of the P-51, cut narrow strips (3/8" to 5/8") and apply them in the corners **before** covering the major surfaces. The larger pieces of Monokote will overlap and capture these smaller strips. This technique also bypasses the need to cut the Monokote in these areas after it has been applied. **DO NOT, under any circumstances, attempt to cut the covering material after it has been applied to the fin and stab, except around the leading and trailing edges and the tip.** Modelers who do this often cut through the covering and part-way into the balsa stab skin. This can weaken the stab to the point where it may fail in flight!

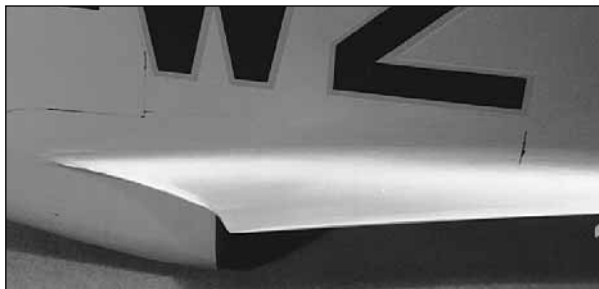

Cover the wing fillet before the rest of the fuselage.

Recommended Covering Sequence:

1. Tail Fillet Strips as described in above note
2. Rudder left side (black)
3. Rudder right side (black)
4. Bottom of elevators
5. Top of elevators
6. Stab bottom
7. Stab top
8. Wing fillet (on fuselage)*
8. Fuse bottom
9. Fuse sides
10. Fuse top
11. Fin left side
12. Fin right side
13. Ends of ailerons and flaps
14. Bottom of ailerons and flaps
15. Top of ailerons and flaps
16. TE surfaces of wing (at ailerons and flaps)
17. Fuselage fairing (on bottom of wing)
18. Bottom of left wing panel
19. Bottom of right wing panel
20. Top of left wing panel (overlap covering 1/4" at wing LE)
21. Top of right wing panel (overlap covering 1/4" at the LE)

****When covering concave surfaces, follow the iron with a damp cloth, pressing the covering down.***

APPLY TRIM

Cover the area ahead of the canopy with Olive Drab Monokote. After the model is covered, but before the canopy is installed, mask and spray this panel with flat clear (such as Chevron Perfect).

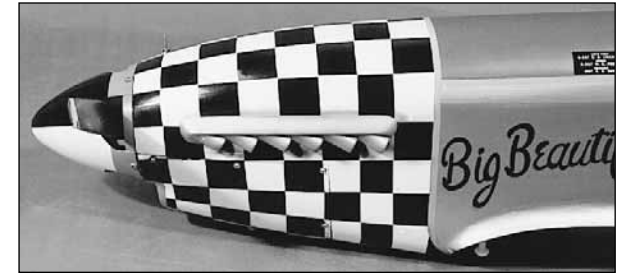

The nose checkerboard was done with Super Monokote, with the exception of the plastic cowling (more on that below.)

The nose checkerboard is not extremely difficult to do. It is, however, tedious and time consuming to apply. Sport modelers who do not want to spend the necessary time on the checkerboards, but still want to use the supplied decals etc., may consider applying a solid colored nose such as red or black instead.

The following is the sequence used on the prototypes.

The cowling should be painted white before proceeding with the checkerboards. K&B or Chevron Perfect paints are recommended.

1. Cover the entire nose section of the model in the checkerboard region with white Monokote.
2. Bolt the lower cowling to the fuselage. If your paint is not extremely durable, you will need to be careful where you put marks on the cowling. We recommend you use a soft #2 pencil when marking on the cowling.
3. Divide the fore/aft distance of the checkerboard region (at the top) into eight sections. **Notice** that these are **NOT** equal length! The checks toward the front are shorter. You may use a fine-tip, permanent marker to mark on the Monokote. Isopropyl alcohol will remove any exposed marks when you are done.

4. Repeat these divisions on the fuselage's left and right sides as well as the bottom.

5. Draw rings around the nose of the plane with the marker (and a pencil on the cowling). The rings should be even all the way around. The rings may be drawn by applying strips of plastic fine-line masking tape around the fuselage, then running the pen around the fuselage using the tape as a guide.

6. Divide the fuselage up radially using the box and other photos as a reference. Use a straightedge or tape to draw the radial (lengthwise) lines on the fuselage and cowl.

7. Mark the section at the front of the cowl that is red. Remove the cowling.

8. Custom cut individual pieces of black Monokote to fit each black panel of the checkerboard. Iron these down as you cut them.

9. To complete the checkerboard, you will need to bolt the wing onto the fuselage and continue the checks onto the fuselage fairing on the forward portion of the wing.

10. Use isopropyl alcohol to remove any exposed marks.

11. Cut a 1/4" strip of red Monokote and iron it along the aft edge of the checks as shown in the photos. Also apply a 1/4" wide red strip along the edge of the olive drab panel.

12. For best results, the white parts of the cowling should be masked and the remainder painted black to complete the checkerboard. The chin of the cowl is painted red.

EXHAUST STACKS



1. Trim the **Exhaust Stacks** as closely as you can.

2. Paint the exhaust stacks. Aluminum Chevron Perfect paint was used on the prototypes.

3. Mark the perimeter of the stacks on the fuselage. Use a pin to perforate the covering underneath the stacks.

4. Roughen the underside of the plastic stacks with sandpaper.

5. Glue on the stacks. CA glue was used on the prototypes.

APPLY DECALS

NOTE: The decal sheet does not give you everything you need to completely trim your model, but it does provide all the intricate detailing and difficult items.

1. Study the plans and the photos on the box to decide where to place the decals.

2. Thoroughly clean your airplane before applying decals.

3. Cut out the individual decals and apply them in the locations shown on the plan.

NOTE: Certain decals are provided that you may use at your discretion.

HINT: To apply decals accurately, use a permanent marker to put small reference marks on the aircraft outside the extents of the decal. Peel the decal backing off. For large decals, spray the aircraft and the glue side of the decal with a 50-50 mixture of water and Windex. Carefully "float" the decal into position. Use a damp paper towel to squeegee the liquid out from under the decal from the middle, outward. Remove the marks with isopropyl alcohol.

4. The "Col. J. D. Landers" decal should be applied **after** the canopy has been glued on.

HINGING

NOTE: Hinging is usually done after covering, but before final trimming.

Hinges are not included in this kit since there are a wide variety of hinges available and most modelers have their own preference. "CA hinges" were used with good results on the primary surfaces of the prototypes (with Robart Hinge Points used on the flaps).

The recommended locations for the hinges are shown on the plans. The cross-sections on the plans also show typical hinge installations.

FINAL CONTROL HARDWARE HOOKUP

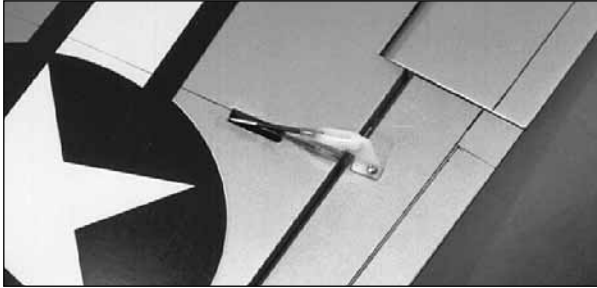

□ 1. Install the flap and aileron horns in line with the pushrod exits as shown on the plans. On the prototypes, 1/16" holes were drilled in the flaps and ailerons at the horn locations. These holes were then thoroughly soaked with thin CA glue. The horns were then glued and screwed in place with #2 x 3/8" **Sheet Metal Screws**. If your balsa appears very soft, it is recommended that you cut a piece of the surface away and install a 1/8" plywood plate into the surface to thread the screws into.

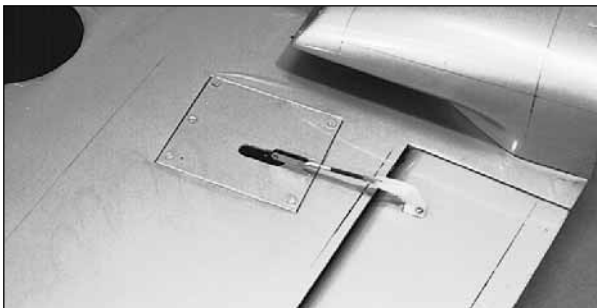

□ 2. Hook up and adjust the aileron and flap

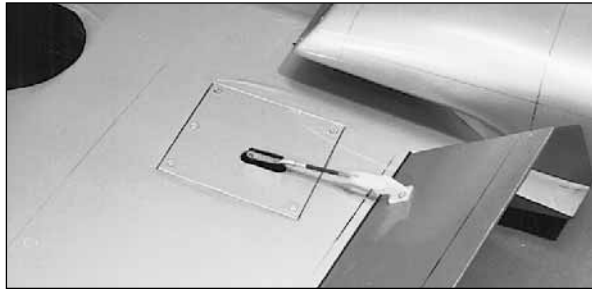

linkages. Two .074 x 12" **Threaded End Rods** are provided to make the flap pushrods. The flap pushrods may be connected to the servos using Z-bends, or solder-on clevises (not included.) Refer to the **Control Surface Throws** section for movement recommendations.

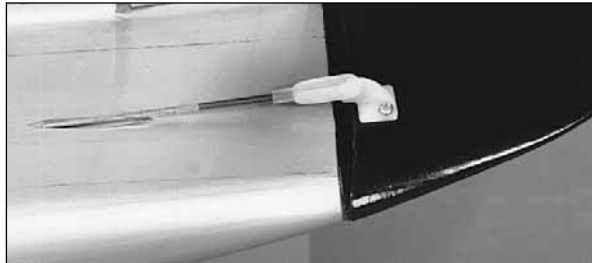

□ 3. The **Rudder** is hooked up using a **Small Control Horn** (cut down to two holes) and a **Nylon Clevis**. Mark the location of the horn and drill two 1/16" pilot holes part way through the rudder. Thoroughly soak the holes with thin CA. Put a drop of CA on the back of the horn and screw the horn onto the rudder with two #2 x 3/8" **Sheet Metal Screws**.

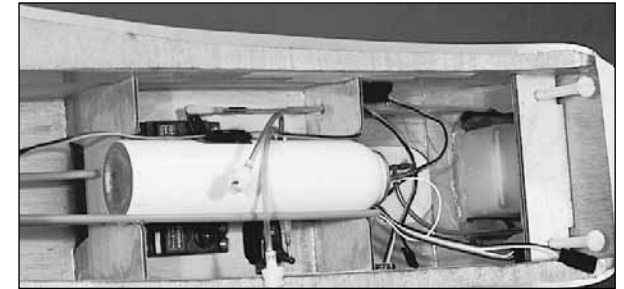

□ 4. The **retract** air valve, tank, and servo installation can be seen in the photos above and below. Die-cut parts are supplied to mount the valve. The tank fits in the built-in cradle in formers F-5 and F-7, and it can be secured with double-sided sticky tape or silicone glue.

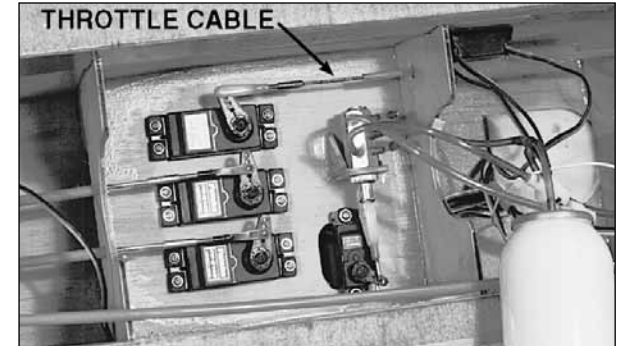

□ 5. Solder-on threaded couplers and Nylon Clevises are recommended for internal **elevator** and **rudder servo** hookups. Refer to the photos and plans for proper servo and horn orientation.

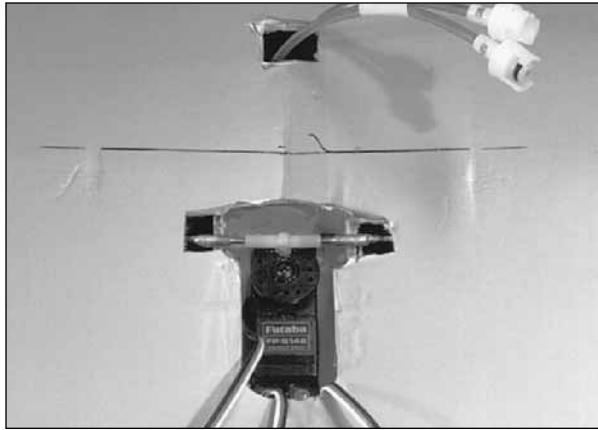

6. The **aileron** servo hookup can be seen in the above photo. It uses a **2-ended ball link** connector and **solder-on Brass Threaded Couplers**. You may want to relieve the pushrod notch in W-1 to allow for some extra clearance.

7. A **throttle** linkage is not included, but a cable, such as the one shown in the photo on the previous page, works well for most installations.

MOUNT THE LANDING GEAR

FIXED LANDING GEAR



1. Locate the slot in the landing gear rail by measuring the location on the plans and marking it on the wing. Probe the area near the marks with a straight pin to confirm the exact location of the slot. Cut away the balsa wing sheeting from over the slot.

- 2. Plug in the bent wire main landing gear.
- 3. Hold the flat **Nylon Straps** in place as shown on the plans. Mark the hole locations.
- 4. Drill 1/16" pilot holes through the marks.

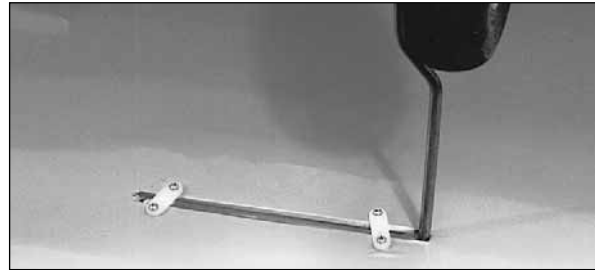

- 5. Secure the landing gear with the nylon straps and #2 x 3/8" **Sheet Metal Screws**.
- 6. Install your wheels.

RETRACTS

- 1. Mark on the lower wing skin the location of your retract and tire. Make a small cut-out to confirm the correct location.



- 2. Gradually increase the size of the cut-out until the retract, strut, and wheel fit properly.

- 3. Mark and drill mounting holes for your retracts.

- 4. You may make wheel well liners from vertical grain 1/16" balsa, 1/64" plywood, or a number of other methods -OR- you may leave your wheel wells open.

- 5. Fuelproof the inside of the wing.

- 6. Hook up the air lines to the retracts and route them to the center of the wing.

- 7. Bolt in the retracts, hook them up, and test their operation.

NOTE: Die-cut landing gear doors are provided in the kit. Refer to the wing plan for installation drawings.

COCKPIT FINISHING (Basic cockpit)

- 1. Sand the inside of the cockpit around the edges with 320-grit sandpaper. True up any uneven edges in the cockpit area.

- 2. Test fit the pilot into the model. Our Williams Brothers scale pilot required a 3/8" block under him to adjust his height. Assemble and paint your pilot.

- 3. You may make a seat back from scrap balsa like the one shown in the photos.

4. Paint the interior of the cockpit. An alternative to paint is to cover the inside of the cockpit with fine-grit black sandpaper for a textured finish. If you use the sandpaper technique, it is still advisable to paint the cockpit corners black first.

5. Paint the frame of the canopy. This can be done from the inside or the outside. The choice is yours. The prototype was painted on the outside, since the glue seems to stick better if the inside is unpainted and roughened with sandpaper.



6. Install the **instrument panel decal**. It may be applied directly to the existing panel. **Hint:** For best results, stick the decal to a scrap piece of 1/64" to 1/16" plywood, trim it to shape, then glue it in place.

7. Cut out and glue the canopy to the model. A "Lexan® scissors," available from your hobby store, works great for this. We recommend using RC-56 glue or 5-minute epoxy, but if you have a favorite technique, use it. You should remove a small strip of MonoKote from under the frame for good glue adhesion. Use masking tape to hold the canopy in place while the glue sets.

INSTALL RECEIVER, SWITCH AND BATTERY

1. Wrap your receiver and battery in plastic bags. Then wrap with foam rubber.

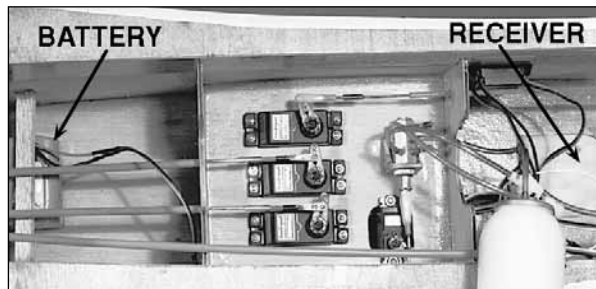

2. Install the **battery** and **receiver** in the fuselage. **NOTE:** The receiver was put through the lightening hole in the crutch between formers F-3 and F-4. The battery can be seen in the photo in the aft portion of the wing saddle area against F-8. The position of the battery and receiver may be changed to balance the aircraft.

3. Route the receiver **antenna** in one of the following ways:

a. Route the antenna along the inside of the fuse side and out of the fuse top, just behind the canopy. Anchor the antenna to the top of the fin with a rubber band.

b. Insert the antenna into a "pushrod guide tube" (not included) and tape it securely at the aft end. Install the tube and antenna into the aft portion of the fuselage through the lightening holes in the fuselage formers. The entire length of the antenna should be extended relatively straight.

BALANCE YOUR MODEL

NOTE: This section is VERY important and must not be omitted!

A model that is not properly balanced will be unstable and possibly unflyable.

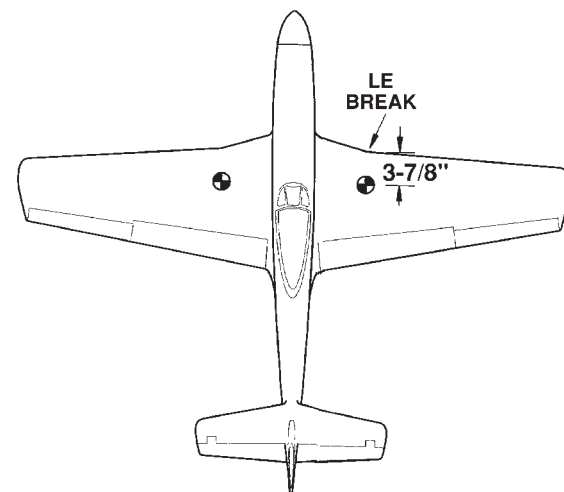

1. Accurately mark the balance point on the **top** of the wing on both sides of the fairing. The balance point is shown on the plan (**CG**), and is located approximately **3-7/8"** back from the leading edge at the "LE break" as shown in the sketch and on the plans. This is the balance point at which your model should balance for your first flights. Later, you may wish to experiment by shifting the balance up to **1/4" forward or back** to change the flying characteristics. Moving the balance **forward** may improve the smoothness and arrow-like tracking, but it may then require more speed for takeoff and make it more difficult to slow down for landing. Moving the balance **aft** makes the model more agile with a lighter and

snappier “feel” and often improves knife-edge capabilities. In any case, **do not balance your model outside the recommended range.**

2. With the wing attached to the fuselage, all parts of the model installed (ready to fly), an **empty** fuel tank, and the landing gear down (extended), hold the model upside-down with the stabilizer level.

3. Lift the model at the C.G. marks. If the tail drops when you lift, the model is “tail heavy” and you must add weight* to the nose to balance. If the nose drops, it is “nose heavy” and you must add weight* to the tail to balance. **NOTE:** Nose weight may be easily installed by using a spinner weight or heavy hub (available in assorted weights), or by gluing strips of lead into the engine compartment. Tail weight may be added by using “stick-on” lead weights, and later, if the balance proves to be OK, you can open the fuse bottom and glue these in permanently.

*If possible, first attempt to balance the model by changing the position of the receiver battery and receiver. If you are unable to obtain good balance by doing so, **then** it will be necessary to add weight to the nose or tail to achieve the proper balance point.

FINAL HOOKUPS AND CHECKS

1. Make sure the control surfaces move in the proper direction as illustrated in the following sketches:

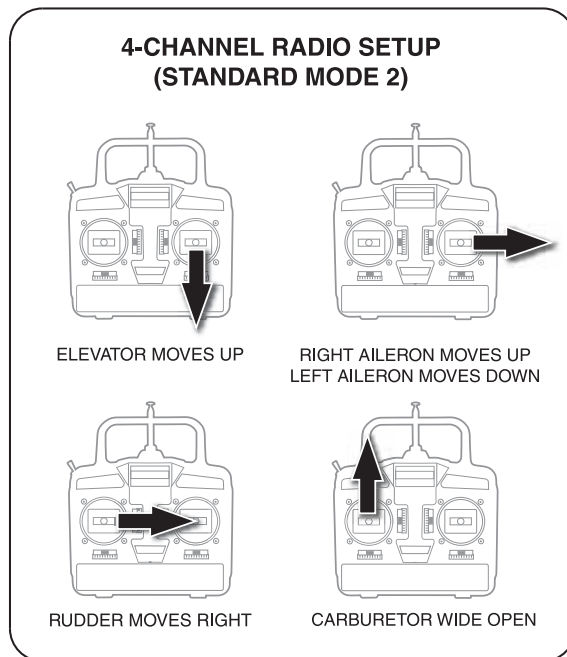

2. Adjust your pushrod hookups as necessary to provide the proper control surface movements as listed at right.

CONTROL SURFACE THROWS:

We recommend the following control surface throws:

NOTE: Throws are measured at the **widest part** of the elevators, rudder, ailerons and flaps.

ELEVATOR:

(High Rate)	11/16" up	11/16" down
(Low Rate)	7/16" up	7/16" down

RUDDER:

(High Rate)	1-1/8" right	1-1/8" left
(Low Rate)	7/8" right	7/8" left

AILERONS:

(High Rate)	11/16" up	11/16" down
(Low Rate)	1/2" up	1/2" down

FLAPS:

(Full Down)	1-11/16" down
-------------	---------------

NOTE: If your radio does not have “dual rates,” then set up the control surfaces to move at the **high rate** throws.

NOTE: These control surface “throws” are approximate and provide a good starting point for the first flights with your P-51D. You may wish to change the throws slightly to provide the smoothness or quickness that you prefer.

PRE-FLIGHT

CHARGE THE BATTERIES

Follow the battery charging procedures in your radio instruction manual. You should **always** charge your transmitter and receiver batteries the night before you go flying, and at other times as recommended by the radio manufacturer.

FIND A SAFE PLACE TO FLY

1. The best place to fly your R/C model is an AMA (Academy of Model Aeronautics) chartered club field. Ask your hobby shop dealer if there is such a club in your area and join. Club fields are set up for R/C flying and that makes your outing safer and more enjoyable. The AMA also can tell you the name of a club in your area. We recommend that you join the AMA and a local club so you can have a safe place to fly and have insurance to cover you in case of a flying accident. The AMA address is listed on page 3.

If a club and its flying site are not available, you need to find a large, grassy area at least 6 miles away from any other R/C radio operation like R/C boats and R/C cars and away from houses, buildings and streets. A schoolyard may look inviting but it is too close to people, power lines and possible radio interference.

GROUND CHECK THE MODEL

If you are not thoroughly familiar with the operation of R/C models, ask an experienced modeler to check to see that you have the radio installed correctly and that all the control surfaces do what they are supposed to. The engine operation also must be checked and the engine "broken-in" on the ground by running the engine for at least two tanks of fuel. **Follow the engine manufacturer's recommendations for break-in.**

Check to make sure that all screws remain tight, that the hinges are secure and that the prop is on tight.

RANGE CHECK YOUR RADIO

Wherever you do fly, you need to check the operation of the radio before every time you fly. This means that, with the transmitter antenna collapsed and the receiver and transmitter on, you should be able to walk at least 100 feet away from the model and still have control. Have someone help you. Have them stand by your model and, while you work the controls, tell you what the various control surfaces are doing.

Repeat this test **with the engine running** at various speeds with an assistant holding the model. If the control surfaces are not always acting correctly, **do not fly!** Find and correct the problem first.

ENGINE SAFETY PRECAUTIONS

NOTE: Failure to follow these safety precautions may result in severe injury to yourself and others.

Keep all engine fuel in a safe place, away from high heat, sparks or flames, as fuel is very flammable. Do not smoke near the engine or fuel; and remember that the engine exhaust gives off a great deal of deadly carbon monoxide. Therefore, **do not run the engine in a closed room or garage.**

Get help from an experienced pilot when learning to operate engines.

Use safety glasses when starting or running engines.

Do not run the engine in an area of loose gravel or sand, as the propeller may throw such material in your face or eyes.

Keep your face and body as well as all spectators away from the plane of rotation of the propeller as you start and run the engine.

Keep items such as these away from the prop: loose clothing, shirt sleeves, ties, scarfs, long hair or loose objects (pencils, screwdrivers) that may fall out of shirt or jacket pockets into the prop.

Use a "chicken stick" device or electric starter; follow instructions supplied with the starter or stick. Make certain the glow plug clip or connector is secure so that it will not pop off or otherwise get into the running propeller.

Make all engine adjustments from **behind** the rotating propeller.

The engine gets hot! Do not touch it during or after operation. Make sure fuel lines are in good condition so fuel is not leaked onto a hot engine, causing a fire.

To stop the engine, cut off the fuel supply by closing off the fuel line or following the engine manufacturer's recommendations. Do not use hands, fingers or any body part to try to stop the engine. Do not throw anything into the prop of a running engine.

AMA SAFETY CODE

Read and abide by the following Academy of Model Aeronautics Official Safety Code:

GENERAL

1. I will not fly my model aircraft in competition or in the presence of spectators until it has been proven to be airworthy by having been previously successfully flight tested.

2. I will not fly my model aircraft higher than approximately 400 feet within 3 miles of an airport without notifying the airport operator. I will give right of way to, and avoid flying in the proximity of, full scale aircraft. Where necessary, an observer shall be used to supervise flying to avoid having models fly in the proximity of full scale aircraft.

3. Where established, I will abide by the safety rules for the flying site I use, and I will not willfully and deliberately fly my models in a careless, reckless and/or dangerous manner.

RADIO CONTROL

1. I will have completed a successful radio equipment ground check before the first flight of a new or repaired model.

2. I will not fly my model aircraft in the presence of spectators until I become a qualified flyer, unless assisted by an experienced helper.

3. I will perform my initial turn after takeoff away from the pit, spectator and parking areas, and I will not thereafter perform maneuvers, flights of any sort or landing approaches over a pit, spectator or parking area.

FLYING

The Top Flite P-51D is a great flying sport scale airplane that flies smoothly and predictably, yet is highly maneuverable. It does **not** have the self-recovery characteristics of a primary trainer. Therefore you must either have mastered the basics of R/C flying or seek the assistance of a competent R/C pilot to help you with your first flights.

TAKEOFF: If you have dual rates on your transmitter, set the switches to "high rate" for takeoff, especially when taking off in a cross wind. Although this P-51 has good low speed characteristics, you should always build up as much speed as your runway will permit before lifting off, as this will give you a safety margin in case of a "flame-out." When you first advance the throttle and the tail begins to lift, the plane will start to turn left (a characteristic of all "tail draggers"). Be ready for this, and correct by applying sufficient right rudder to hold it straight down the runway. The left-turning-tendency will

go away as soon after the tail is up and the plane picks up speed. Be **sure** to allow the tail to come up. Depending on the surface you are flying from, you will need to apply very little to no up elevator until flying speed is obtained. Holding the tail on the ground with too much up elevator will cause the Mustang to become airborne prematurely. When the plane has sufficient flying speed, lift off by smoothly applying up elevator (don't "jerk" it off to a vertical climb!), and climb out gradually.

FLYING: We recommend that you take it easy with your Mustang for the first several flights and gradually "get acquainted" with this fantastic ship as your engine gets fully broken-in. Add and practice one maneuver at a time, learning how she behaves in each. For ultra-smooth flying and normal maneuvers, we recommend using the "low rate" settings as listed on page 55. "High rate" elevator and rudder may be required for crisp snap rolls and spins. "High rate" rudder is best for knife-edge. **Speed** is the key to good knife-edge performance.

LANDING: When it's time to land, fly a normal landing pattern and approach. The Mustang will probably bleed off airspeed more rapidly than the sport planes you are used to. For this reason, keep a few clicks of power on until you are over the runway threshold. For your first landings, plan to land slightly faster than stall speed and on the main wheels, as this is the easiest way to land your Mustang. Later, with a little technique, you will find you can make slow, 3-point landings.

Full flaps make the Mustang feel like a trainer in the landing pattern. Just carry a little extra power to make up for the extra drag. The extra drag of the flaps also allows you to make shorter, steeper approaches. Touch and go's and go-arounds can be accomplished with full flaps, but just be ready to use a little more up elevator.

CAUTION

(THIS APPLIES TO ALL R/C AIRPLANES): If, while flying, you notice any unusual sounds, such as a low-pitched "buzz," this may be an indication of control surface "flutter." Because flutter can quickly destroy components of your airplane, any time you detect flutter you must immediately cut the throttle and land the airplane! Check all servo grommets for deterioration (this will indicate which surface fluttered), and make sure all pushrod linkages are slop-free. If it fluttered once, it probably will flutter again under similar circumstances unless you can eliminate the slop or flexing in the linkages. Here are some things which can result in flutter: Excessive hinge gap; not mounting control horns solidly; sloppy fit of clevis pin in horn; elasticity present in flexible plastic pushrods; side-play of pushrod in guide tube caused by tight bends; sloppy fit of Z-bend in servo arm; insufficient glue used when gluing in the elevator joiner wire or aileron torque rod; excessive flexing of aileron, caused by using too soft balsa aileron; excessive "play" or "backlash" in servo gears; and insecure servo mounting.

Have a ball! But always stay in control and fly in a safe manner.

ALSO AVAILABLE FROM TOP FLITE



O.S.® .61 FX

Easy to start and maintain, the .61 FX offers 1.9 hp of hard-charging sport power for sizzling aerobatics. Fins on the semi-squared head and 1-piece crankcase carry away performance-killing heat. Dual bearings, a balanced crankshaft and O.S.'s exclusive ABL (Advanced Bimetallic Liner) smooth away friction and vibration, reducing heat, wear and wasted power. The high-speed needle on the 60C carb is remote mounted for pilot safety, and equipped with an O-ring seal and ratchet spring to hold settings tight against creep. A versatile mounting bracket provides horizontal and vertical mounting options for installation ease. **OSMG0561**



O.S. FS-91 Surpass™ II

The first impression most modelers have of the ringed FS-91 II is raw power. But the most lasting impression it leaves is for its durability. CAD-assisted engineering and CNC-machined parts ensure the fit and finish; a permanently lubricated, rubber-sealed rear bearing and corrosion-resistant plating on the crankshaft, camshaft and piston help minimize wear and maximize performance. Bolt in an FS-91 II, and a large-scale plane can go from a short roll-out to rocketing vertical to out-of-sight in the span of a few seconds. The power to impress is always there — and along with it, improved fuel economy and a mellower, more scale-like sound. The needle valve and mixture control screw are on the same side of a reversible carb to offer maximum installation and access ease. **OSMG0896**



SuperTigre® G-75 Ring

It fits where a G-61 would, but delivers almost 18% more power for maneuvers and climbs. Designed for beam mounting, the G-75 offers the distortion-resistant strength of a 1-piece crankcase and a dual bearing-supported crankshaft for smooth, friction-free operation. A rugged ringed piston ensures high performance and long life; a thermally treated, low-friction steel sleeve keeps temperatures at acceptable levels. A squared, lightweight cast head helps dissipate heat and hold performance at peak. Includes a glow plug, bolt-through muffler and a dual-needle carb. **SUPG0205**



Futaba® S9001 BB Servo

Ideal for a wide range of applications, these servos both feature a coreless motor for smooth, speedy response and improved resolution. S9001 for airplanes has a single ball bearing, and comes with one attached servo horn and three extra servo horns; S9202 is ideal for both planes and helis, and boasts dual ball bearings for even more smoothness. **FUTM0075**

TWO-VIEW DRAWING

Use this layout for trim
scheme planning only.
Not suitable for scale
documentation.

