

THE BRISTOL M1 WAS DESIGNED AS A WWI FIGHTER - A RADICAL DEPARTURE FROM THE USUAL BIPLANES OF THE DAY. IT WAS ORIGINALLY POWERED BY A LE RHONE RADIAL ENGINE, HIDDEN BEHIND A LARGE SPINNER AND AS A RESULT HAD A VERY SHORT NOSE. ONLY 125 MIS WERE PRODUCED, AND 9 FOUND THEIR WAY INTO THE HANDS OF PRIVATE OWNERS FOLLOWING THE WAR. TWO BRISTOL MICS WERE IMPORTED INTO AUSTRALIA BY HARRY BUTLER (WHO LATER DIED AFTER THE CRASH OF ONE OF HIS AIRCRAFT). ONE OF THE M1S (2819, "RED DEVIL") WAS PURCHASED BY HORRIE MILLER WHO CONVERTED IT FOR RACING BY REPLACING THE RADIAL ENGINE WITH A GYPSY IN-LINE ENGINE AND SLIMMING DOWN THE FUSELAGE TO MATCH THE SLIMMER ENGINE. VH-UYG WAS LATER PUT ON DISPLAY IN MINLATON (BUTLER'S HOME TOWN) RE-PAINTED IN ITS ORIGINAL ALL-OVER RED WITH RAF ROUNDELS AND SPORTING A RADIAL ENGINE ONCE MORE.

X = BRACING WIRE ATTACHMENT POINTS

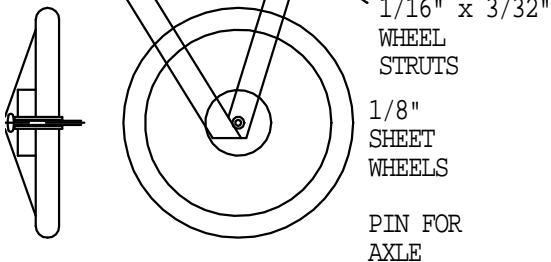
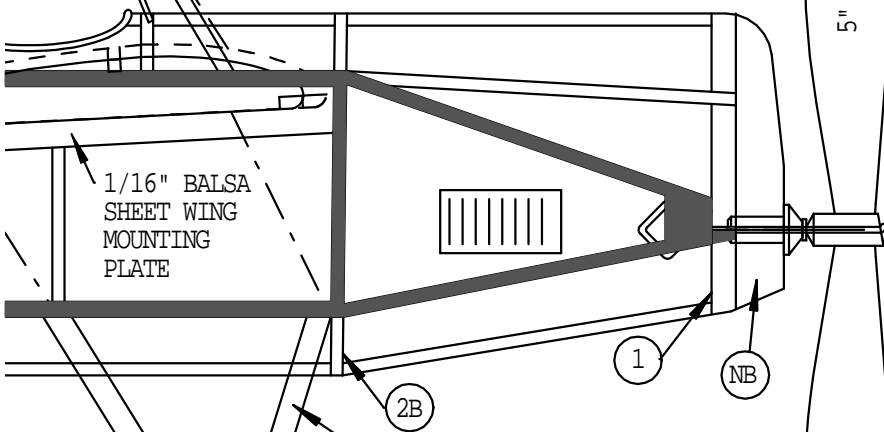
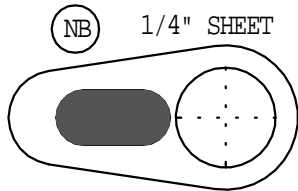
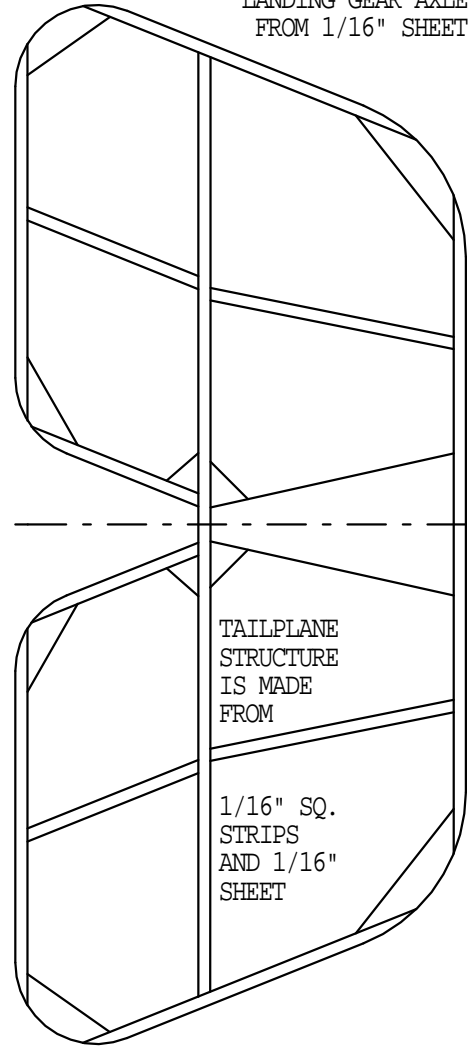
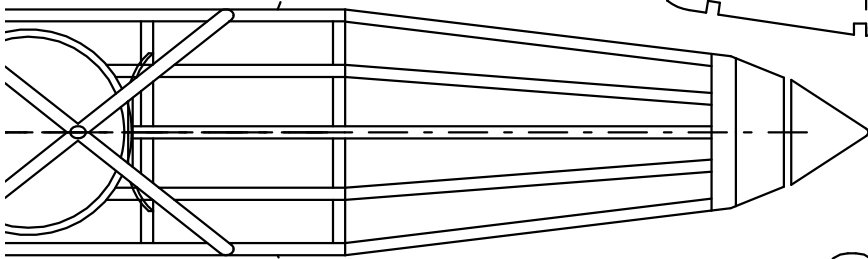
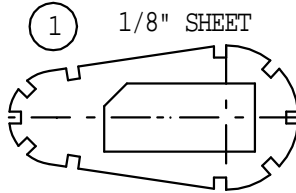
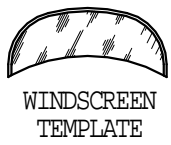
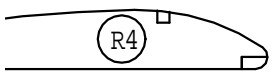
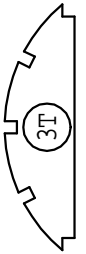
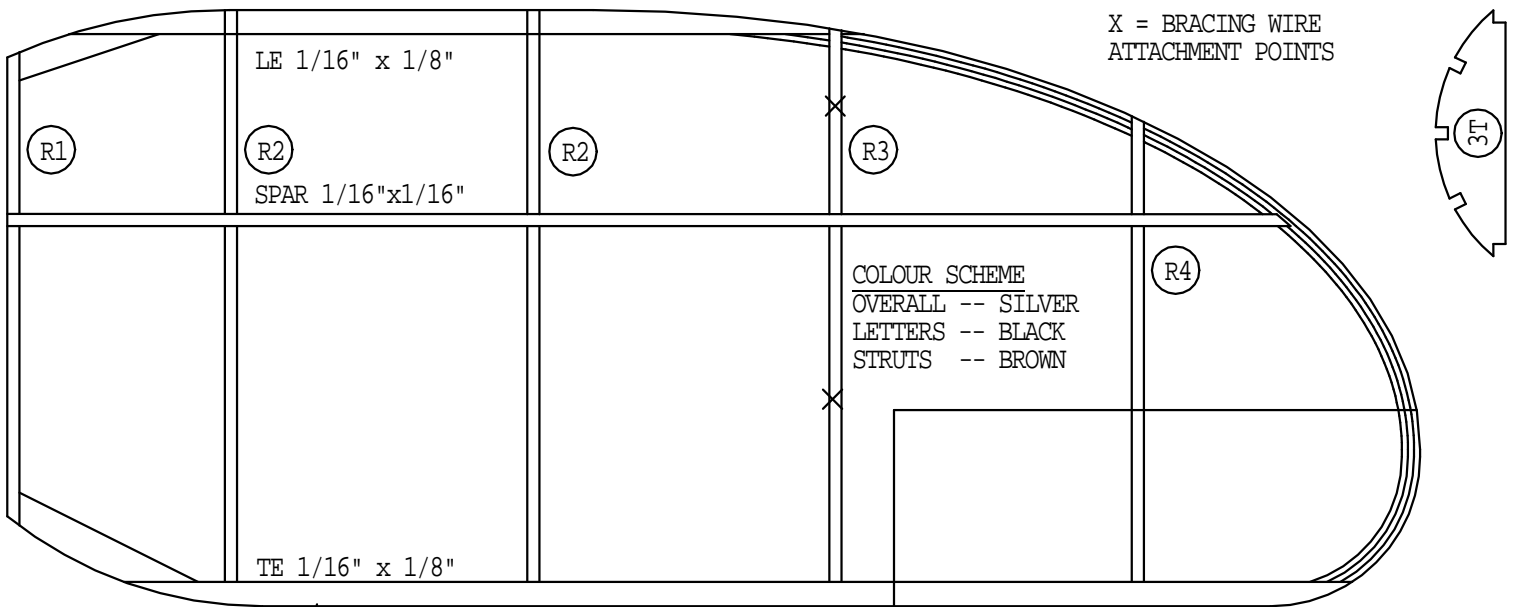

BRISTOL M1 GYPSY RACER

WINGSPAN - 16"

LENGTH - 12 1/2"

DRAWING NO. NDS01

SERIES - NEO DIME SCALE

DRAWN BY - DJB

LETTERED BY - DJB